

# STORMWATER QUALITY DESIGN MANUAL

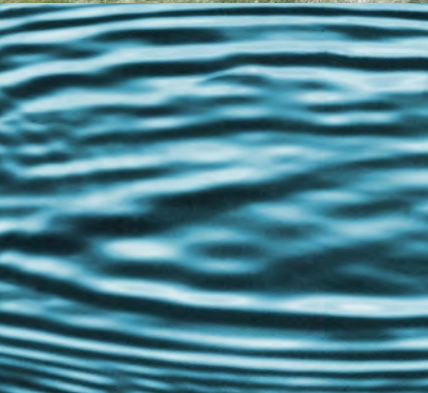

Integrated Design Solutions  
for Urban Development

Protecting Our Water Quality



City of Citrus Heights  
City of Elk Grove  
City of Folsom  
City of Galt

City of Rancho Cordova  
City of Sacramento  
County of Sacramento

THIS PAGE LEFT INTENTIONALLY BLANK

# Table of Contents

---

<b>List of Tables</b> .....	<b>vii</b>
<b>List of Figures</b> .....	<b>ix</b>
<b>List of Appendices</b> .....	<b>xi</b>
<b>Acknowledgements</b> .....	<b>xiii</b>
Steering Committee.....	xiii
Project Consultants.....	xiii
Document Design and Production.....	xiii
Other Development Community Reviewers and Contributors .....	xiv
Agency Reviewers and Contributors .....	xiv
<b>Disclaimer</b> .....	<b>xv</b>
<b>Glossary</b> .....	<b>xvii</b>
<b>Chapter 1. Introduction</b> .....	<b>1-1</b>
Purpose.....	1-1
Goals .....	1-1
Background Information .....	1-2
Sacramento Areawide Stormwater Permit Requirements .....	1-2
Agency Collaboration in Developing this Manual.....	1-3
Using the Manual .....	1-3
Intended Audience .....	1-3
Projects Covered by the Manual.....	1-4
How the Manual is Organized.....	1-6
Stormwater Management Information Not in this Manual.....	1-7
Obtaining the Manual and Updates .....	1-8
Questions and Comments.....	1-8
<b>Chapter 2. Integrated Approach to Stormwater Management</b> .....	<b>2-1</b>
Integrated Planning and Design Approach .....	2-1
Benefits of the Integrated Approach.....	2-1
Benefits to the Property Owner/Developer.....	2-1
Environmental Benefits.....	2-1

## Table of Contents

Community Benefits.....	2-2
Strategies for Effectively Integrating Stormwater Quality Management into Project Design .....	2-2
Assemble a Collaborative Team Early.....	2-2
Consider the Site and its Surroundings .....	2-3
Identify Opportunities and Constraints .....	2-3
Preserve Valuable Site Features .....	2-4
Lay Out the Site with Topography and Soils in Mind.....	2-4
Put Landscaping to Work.....	2-5
Stop Pollution at Its Source .....	2-5
Reduce Runoff Close to Its Source.....	2-5
Treat Runoff.....	2-7
Hydromodification Management.....	2-7
References.....	2-7
Additional Resources .....	2-8
<b>Chapter 3. Steps to Managing Stormwater Quality .....</b>	<b>3-1</b>
Step 1. Gather Project and Site Information.....	3-1
Step 2. Determine Requirements.....	3-3
Step 3. Evaluate Best Approach to Protect Stormwater Quality .....	3-9
Step 4. Select Source Control Measures (Chapter 4) .....	3-9
Step 5. Select Hydromodification Control Measures (Chapter 5).....	3-10
Step 6. Select Low Impact Development Measures (Chapter 5).....	3-10
Step 7. Select Treatment Control Measures (Chapter 5).....	3-11
Step 8. Design Facilities (Preliminary).....	3-12
Step 9. Design Facilities (Final).....	3-12
Step 10. Establish Long Term Maintenance Requirements .....	3-13
Step 11. Construct.....	3-13
<b>Chapter 4. Source Control Measures.....</b>	<b>4-1</b>
Source Control Principles .....	4-1
Selecting Source Control Measures for Your Project .....	4-2
Source Control Fact Sheets .....	4-2
References.....	4-2
Fact Sheets:	

Efficient Irrigation..... EI-1

Fueling Areas ..... FA-1

Landscaping..... L-1

Loading Areas ..... LA-1

Outdoor Storage Areas ..... OS-1

Outdoor Work Areas ..... OW-1

Storm Drain Inlet Markings and Signage ..... SD-1

Wash Areas ..... WA-1

Waste Management Areas ..... WM-1

**Chapter 5. Hydromodification Management, Low Impact Development, and Treatment Control Measures ..... 5-1**

Introduction ..... 5-1

Hydromodification Control Principles and Applicability ..... 5-2

    Projects Located in an Exempted Area ..... 5-3

    Municipal Agency Projects..... 5-4

    Prior Approved Projects..... 5-4

    Priority Projects ..... 5-5

    Discharges Directly to Exempted Channels ..... 5-5

    Redevelopment Projects..... 5-6

Selecting Hydromodification Controls for Your Project ..... 5-9

Designing Hydromodification Controls ..... 5-9

    Alternative Design Approaches for Hydromodification Management ..... 5-11

Low Impact Development Principles ..... 5-11

    Open Space Preservation..... 5-12

    Runoff Reduction ..... 5-13

    Runoff Management..... 5-14

Selecting Low Impact Development Measures for Your Project ..... 5-15

Low Impact Development Points Worksheets..... 5-16

Treatment Control Principles ..... 5-16

Selecting Treatment Control Measures..... 5-17

Designing Treatment Control Measures..... 5-18

## Table of Contents

Volume-Based Design (WQV) .....	5-18
Flow-Based Design (WQF) .....	5-18
Proprietary Treatment Control Measures .....	5-18
Operation and Maintenance .....	5-19
References.....	5-20
Fact Sheets .....	5-23
Fact Sheets:	
Alternative Driveways .....	AD-1
Bioretention Planter.....	BP-1
Compost-Amended Soil.....	CAS-1
Constructed Wetland Basin .....	CWB-1
Disconnected Pavement .....	DP-1
Disconnected Roof Drains .....	DRD-1
Green Roof.....	GR-1
Infiltration Basin .....	IB-1
Infiltration Trench.....	IT-1
Interceptor Trees.....	INT-1
Porous Pavement .....	PP-1
Sand Filter .....	SF-1
Underground Storage.....	US-1
Vegetated Filter Strip .....	VFS-1
Vegetated Swale.....	VS-1
Water Quality Detention Basins.....	DB-1
<b>Chapter 6. Green Streets.....</b>	<b>6-1</b>
Description .....	6-1
Applicability .....	6-1
Design Process Overview .....	6-2
Design Procedure.....	6-2
Step 1 – Address Site Layout Issues.....	6-2
Step 2 – Incorporate Alternative Transportation Options .....	6-2
Step 3 – Choose Stormwater Facilities.....	6-2

Step 4 – Perform Final Sizing of Stormwater Facilities and Implement Detailed Design Strategies ..... 6-6

Maintenance Issues ..... 6-8

References..... 6-9

THIS PAGE LEFT INTENTIONALLY BLANK



# List of Tables

---

Table 1-1	Applying the Design Manual to Every Phase of Development .....	1-5
Table 1-2	Types of Projects Addressed by This Manual .....	1-6
Table 3-1	Project Categories and Associated Potential Pollutants .....	3-2
Table 3-2	Required Stormwater Quality Control Measures for Priority Projects.....	3-4
Table 3-3	Stormwater Quality Control Measure Selection Matrix.....	3-6
Table 5-1	Summary of Control Measure Functionality .....	5-2
Table 6-1	Summary Table of LID Incorporation within Green Streets.....	6-6
Table FA-1	Design Requirements for Fueling Areas to Protect Water Quality .....	FA-2
Table L-1	Fertilizer Comparison.....	L-3
Table LA-1	Design Requirements for Loading Areas to Protect Water Quality .....	LA-2
Table OS-1	Design Requirements for Outdoor Storage Areas to Protect Water Quality .....	OS-2
Table OW-1	Design Requirements for Outdoor Work Areas to Protect Water Quality .....	OW-2
Table SD-1	Design Requirements for Storm Drain Inlet Markings and Signage .....	SD-1
Table WA-1	Design Requirements for Equipment and Vehicle Wash Areas to Protect Water Quality.....	WA-2
Table WM-1	Design Requirements for Waste Management Areas to Protect Water Quality .....	WM-2
Table AD-1	Alternative Driveways Design Criteria.....	AD-4
Table BP-1	Bioretention Planter Design Criteria .....	BP-4
Table BP-2	Inspection and Maintenance Recommendations for Bioretention Planters .....	BP-8
Table BP-3	Design Data Summary Sheet for Bioretention Planter.....	BP-9
Table CAS-1	Compost-Amended Soil Design Criteria.....	CAS-4
Table CAS-2	Inspection and Maintenance Recommendations for Compost-Amended Soils .....	CAS-7
Table CAS-3	Design Data Summary Sheet for Compost-Amended Soils .....	CAS-8
Table CWB-1	Constructed Wetland Basin Design Criteria.....	CWB-4
Table CWB-2	Distribution of Wetland Components .....	CWB-5
Table CWB-3	Inspection and Maintenance Recommendations for Constructed Wetland Basins .....	CWB-9
Table CWB-4	Design Data Summary Sheet for Constructed Wetland Basin.....	CWB-11
Table DP-1	Disconnected Pavement Design Criteria .....	DP-6
Table DRD-1	Conveyance Zone for Splash Blocks and Pop-up Drainage Emitters: Commercial and Multi-Family Residential Areas.....	DRD-3
Table DRD-2	Disconnected Roof Drains Design Criteria.....	DRD-9
Table DRD-3	Inspection and Maintenance Recommendations for Dispersal Trenches and Infiltration Wells.....	DRD-11
Table GR-1	Green Roof Design Criteria.....	GR-4
Table GR-2	Inspection and Maintenance Recommendations for Green Roofs .....	GR-10

## List of Tables

Table GR-3	Design Data Summary Sheet for Green Roof.....	GR-13
Table IB-1	Infiltration Basin Design Criteria.....	IB-3
Table IB-2	Inspection and Maintenance Recommendations for Infiltration Basins .....	IB-9
Table IB-3	Design Data Summary Sheet for Infiltration Basin.....	IB-10
Table IT-1	Infiltration Trench Design Criteria.....	IT-3
Table IT-2	Inspection and Maintenance Recommendations for Infiltration Trenches .....	IT-6
Table IT-3	Design Data Summary Sheet for Infiltration Trench.....	IT-10
Table INT-1	Design Criteria for Interceptor Trees .....	INT-5
Table INT-2	Inspection and Maintenance Recommendations for Interceptor Trees .....	INT-7
Table PP-1	Design Criteria for Porous Pavement .....	PP-11
Table PP-2	Inspection and Maintenance Recommendations for Porous Pavement .....	PP-12
Table PP-3	Selected Local Pervious Concrete Installations.....	PP-13
Table SF-1	Austin Sand Filter Design Criteria .....	SF-3
Table SF-2	Geotextile Fabric and Drainage Matting Specifications for Sand Filters .....	SF-11
Table SF-3	Inspection and Maintenance Recommendations for Sand Filters .....	SF-13
Table SF-4	Design Data Summary Sheet for Sand Filter.....	SF-15
Table US-1	Inspection and Maintenance Recommendations for Underground Storage.....	US-5
Table US-2	Design Data Summary Sheet for Underground Storage.....	US-6
Table VFS-1	Vegetated Filter Strip Design Criteria .....	VFS-3
Table VFS-2	Inspection and Maintenance Recommendations for Vegetated Filter Strips....	VFS-6
Table VFS-3	Design Data Summary Sheet for Vegetated Filter Strip .....	VFS-7
Table VS-1	Vegetated Swale Design Criteria.....	VS-4
Table VS-2	Inspection and Maintenance Recommendations for Vegetated Swales .....	VS-7
Table VS-3	Design Data Summary Sheet for Vegetated Swale.....	VS-10
Table DB-1	Water Quality Detention Basin Design Criteria .....	DB-5
Table DB-2	Dry Weather Design Flows .....	DB-9
Table DB-3	Plants for Areas that are Periodically Inundated .....	DB-13
Table DB-4	Plants to Use In/Adjacent to a Permanent Pond .....	DB-14
Table DB-5	Inspection and Maintenance Recommendations for Water Quality Detention Basins .....	DB-16
Table DB-6	Design Data Summary Sheet for Water Quality Detention Basin .....	DB-23

# List of Figures

---

Figure 3-1	Identifying Stormwater Quality Requirements for New Development and Redevelopment Projects .....	3-8
Figure 5-1	Hydromodification Mitigation Applicability Flow Chart.....	5-7
Figure 5-2	Applicability Map.....	5-8
Figure 5-3	Visual Demonstration of the HMP Performance Criteria .....	5-10
Figure LA-1	Recommended Loading Area Drainage Design.....	LA-4
Figure SD-1	Storm Drain Inlet Message .....	SD-3
Figure BP-1	Infiltration Bioretention Planter Configuration .....	BP-7
Figure BP-2	Flow-through Bioretention Planter Configuration.....	BP-8
Figure CAS-1	Compost-Amended Soil Section.....	CAS-6
Figure CWB-1	Constructed Wetland Basin.....	CWB-10
Figure DRD-1	Dispersal Trench – Typical Sections .....	DRD-6
Figure DRD-2	Infiltration Well – Typical Sections.....	DRD-8
Figure GR-1	Typical Green Roof Configuration .....	GR-5
Figure IB-1	Infiltration Basin .....	IB-7
Figure IT-1	Infiltration Trench .....	IT-7
Figure IT-2	Infiltration Vault .....	IT-8
Figure IT-3	Infiltration Leach Field .....	IT-9
Figure PP-1	Typical Pervious Concrete Sections .....	PP-5
Figure PP-2	Modular Block Pavement, Typical Section .....	PP-6
Figure PP-3	Reinforced Grass Pavement, Typical Sections .....	PP-8
Figure PP-4	Cobblestone Block Pavement, Typical Section.....	PP-9
Figure PP-5	Porous Gravel Pavement, Typical Sections.....	PP-10
Figure SF-1	Sand Filter Configuration (Austin Sand Filter) .....	SF-5
Figure SF-2	Example Sediment Trap Details .....	SF-8
Figure SF-3	Filter Bed with Gravel Underdrain.....	SF-12
Figure SF-4	Filter Bed with Trench Underdrain.....	SF-12
Figure VFS-1	Vegetated Filter Strip.....	VFS-5
Figure VS-1	Vegetated Swale .....	VS-9
Figure DB-1	Park Incorporating Water Quality Detention with Wet Pond .....	DB-4
Figure DB-2	Water Quality Detention Pond Incorporating Wet Pond and Natural Contours.....	DB-4
Figure DB-3	Basin Criteria to Control Stormwater Pollution .....	DB-7
Figure DB-4	Dry Extended Stormwater Quality Detention Basin .....	DB-19
Figure DB-5	Low Flow Channel .....	DB-20
Figure DB-6	Outfall Structure .....	DB-21
Figure DB-7	Outfall Structure Access Ramp .....	DB-22

THIS PAGE LEFT INTENTIONALLY BLANK

# List of Appendices

---

- Appendix A. Submittal Requirements
- Appendix B. Maintenance Requirements
- Appendix C. Connecting to the Sanitary Sewer System General Requirements
- Appendix D. Low Impact Development Credits and Calculation Worksheets
- Appendix E. Design Requirements for Stormwater Quality Treatment Control Measures
- Appendix F. Drainage Design and Stormwater Management Information Not Included in the Design Manual
- Appendix G. Inspection Checklist for Stormwater Control Measures
- Appendix H. Amendment to the Water Quality Control Plan for Ocean Waters of California to Control Trash (Ocean Plan) and Certified Full Capture Systems List of Trash Treatment Control Devices
- Appendix I. Bioretention Soil Media Specifications
- Appendix J. Plant Selection Guidance

THIS PAGE LEFT INTENTIONALLY BLANK

# Acknowledgements

---

This design manual was made possible by the combined efforts of many professionals:

## Steering Committee

Sherill Huun, PE, City of Sacramento  
Dalia Fadl, PE, City of Sacramento  
Hong Lin, Ph.D., PE, formerly with City of Sacramento  
Archie Wright, PE, Sacramento County  
Dana Booth, PG, Sacramento County  
Mark Rains, PE, Sacramento County  
Michael Johnson, PE, Sacramento County  
Heidi Huber, Sacramento County  
Sarah Staley, PE, formerly with City of Folsom  
Fernando Duenas, PE, City of Sacramento  
Darren Wilson, PE, formerly with City of Elk Grove  
Bill Forrest, PE, City of Galt  
Chris Fallbeck, PE, formerly with City of Citrus Heights  
Britton Snipes, PE, formerly with City of Rancho Cordova  
Allen Quynn, PE (WA), City of Rancho Cordova

## Project Consultants<sup>1</sup>

Scott Taylor, PE, Michael Baker International  
Richard Lucera, PE, Michael Baker International  
Scott Cartwright, PE, Michael Baker International  
Hilary Ellis, Michael Baker International  
Brian Currier, Office of Water Programs (OWP)  
Doug Beyerlein, Clear Creek Solutions  
Jennifer Walk, Watearth

## Document Design and Production

Joan Kodani, formerly with Sacramento County  
Sara Redfern, formerly with Sacramento County  
Hilary Ellis, Michael Baker International (cover)

---

<sup>1</sup> Original Authors: Carmel K. Brown, P.E. CKB Environmental Consulting, Inc.; Shannon Brown, ECORP Consulting; Robert Smith, P.E. and Mack Walker, P.E., Larry Walker Associates; Mark Kubik, P.E., West-Yost Associates; Carlos Espana, P.E., G.E., Furgo West, Inc.; N. Alison Tucker

## Other Development Community Reviewers and Contributors

Development Focus Group meetings were held in October 2017. Comments were solicited on the 2017 draft manual. Attendance lists from these meetings are available upon request. The public draft was published in October 2017, followed by one public workshop on October 27, 2017. A compilation of all written comments received, and corresponding Steering Committee responses, can be found at: <http://www.beriverfriendly.net/> (new development).

## Agency Reviewers and Contributors

Staff from the various local and regional agencies reviewed and commented on the 2017 Public Agency Review Draft Design Manual and various subsequent drafts. In particular, the Design Manual Steering Committee would like to acknowledge the contributions of these agencies and individuals:

Ken Menzer, Arborist, City of Folsom



# Disclaimer

---

The Stormwater Quality Design Manual for the Sacramento Region should be used as a general guidance document to aid with the selection, siting, design, operation and long-term maintenance of stormwater quality control measures. The control measures described herein are intended to serve as best management practices (BMPs) implemented to meet the standard of “reducing pollutants in urban runoff to the maximum extent practicable” set forth in the local agencies’ NPDES Municipal Stormwater Permits issued by the Central Valley Regional Water Quality Control Board.

The stormwater quality control measures should be designed using the criteria outlined in this manual and implemented at areas of new development and redevelopment in accordance with the policies and procedures of the local permitting agency. The control measures must be properly constructed and maintained to ensure long-term performance. Other measures not included in this manual may be allowed on a case-by-case basis, in consultation with the applicable permitting agency. In such cases, the applicant is encouraged to meet with permitting agency staff early in the planning process before proceeding with detailed design. Such projects may require additional time for agency review and approval.

The contributing agencies do not claim any responsibility for errors or omissions in this design manual, improper design, or ineffective maintenance practices that might contribute to non-performance of the stormwater quality control measures. The agencies will share the responsibility of verifying that publicly owned and maintained treatment controls are constructed properly; however, private controls are the owners’/applicants’ responsibility.

Most of the control measures described in this manual should be designed by, or under the supervision of, a California licensed professional engineer and/or other specialists as needed, depending on the type of control measure and site conditions. Check with the local permitting agency to verify the license requirement for the design project undertaken.

The science of stormwater quality management is evolving and new and innovative control measure technologies are constantly being introduced to design professionals. For this reason, this manual will need to be a dynamic document that will be reviewed and updated periodically. Manual users are responsible for ensuring that they are referencing the most current edition, by checking [www.beriverfriendly.net](http://www.beriverfriendly.net) (new development) or contacting their local permitting agency.

THIS PAGE LEFT INTENTIONALLY BLANK

# Glossary

---

The following are the terms and acronyms used frequently in this Manual. This list is not intended to be exhaustive.

**Alternative driveway** – A low impact development design application that involves replacing all or a portion of a standard impervious driveway with pervious materials such as grass or pavers.

**Best Management Practices (BMPs)** - Methods, measures, or practices designed and selected to reduce or eliminate the discharge of pollutants to surface waters from point and non-point source discharges including stormwater. BMPs include structural and nonstructural controls, and operation and maintenance procedures, which can be applied before, during, and/or after pollution producing activities.

**Bioretention Planter**– Also referred to as Stormwater Planter. A BMP designed to detain or retain stormwater runoff from impervious surfaces using a vegetated surface depression and engineered soil section. Bioretention can reduce and treat stormwater runoff and associated pollutants through evapotranspiration, filtration, and infiltration.

**California Stormwater Quality Association (CASQA)** – Statewide association of stormwater quality managers and other interested parties. Publisher of the California Stormwater Best Management Practices Handbooks, available at [www.cabmphandbooks.com](http://www.cabmphandbooks.com). Successor to the Storm Water Quality Task Force (SWQTF).

**Cluster Development** – Incorporates grouping new homes onto part of a development parcel so that the remaining land can be preserved as open space. This approach can save a significant portion of the land and provide an attractive living environment for homeowners. Source: National Assoc. of Homebuilders [www.nahb.org](http://www.nahb.org) (search “cluster development”)

**Commercial Development** - Any development on private land that is not heavy industrial or residential. The category includes, but is not limited to hospitals, laboratories and other medical facilities, educational institutions, recreational facilities, plant nurseries, car wash facilities, mini-malls, business complexes, shopping malls, hotels, office buildings, public warehouses, and light industrial complexes.

**Commercial/Industrial Facility** - Any facility involved and/or used in the production, manufacture, storage, transportation, distribution, exchange or sale of goods and/or commodities, and any facility involved and/or used in providing professional and non-professional services. This category of

---

*In the stormwater field, terms are frequently used interchangeably; therefore, it is important to understand the meaning of various terms as presented in this Manual.*

---

## Glossary

facilities includes, but is not limited to, any facility defined by the SIC Code. Facility ownership (federal, state, municipal, private) and profit motive of the facility are not factors in this definition.

**Construction** - Clearing, grading, excavating, building and related activities that result in soil disturbance. Construction includes structure teardown. It does not include routine maintenance to maintain original line and grade, hydraulic capacity, or original purpose of facility; emergency construction activities required to immediately protect public health and safety; interior remodeling with no outside exposure of construction material or construction waste to stormwater; mechanical permit work; or sign permit work.

**Construction General Permit** – The general NPDES permit adopted by the State Board, which authorizes the discharge of stormwater from construction activities under certain conditions.

**Control** - To minimize, reduce, eliminate, or prohibit by technological, legal, contractual or other means, the discharge of pollutants from an activity or activities.

**Design Storm** – A synthetic rainstorm defined by rainfall intensities and durations.

**Detention** – The practice of holding stormwater runoff in ponds, vaults, within berms, or in depressed areas and letting it discharge slowly to the storm drain system or receiving water. The detention process allows sediment and associated pollutants to settle out of the runoff.

**Developable Area** – Vacant or under-developed parcels that have not been developed to their current zoning as described in the regional land use map.

**Development** - Any construction, rehabilitation, redevelopment or reconstruction of any public or private residential project (whether single-family, multi-unit or planned unit development); industrial, commercial, retail and other non-residential projects, including public agency projects; or mass grading for future construction. It does not include routine maintenance to maintain original line and grade, hydraulic capacity, or original purpose of facility, nor does it include emergency construction activities required to immediately protect public health and safety.

**Development Standards** - Standards that the Permittees must develop and implement for new development and significant redevelopment projects to control the discharge of stormwater pollutants in post-construction runoff.

**Direct Discharge** – A discharge that is routed directly to the receiving water by means of pipe, channel, or ditch (including municipal storm sewer systems), or through surface runoff.

**Directly Connected Impervious Area (DCIA) or Surface** – Any impervious surface which drains directly into the storm drain system without first allowing flow across a pervious area (e.g. lawn).

**Disconnected Pavement (also known as disconnected impervious area, or surface, or not directly connected pavement)** – An impervious area that drains across a pervious area prior to discharge to the storm drain system.

**Drawdown Time** – The time required for a stormwater detention or infiltration BMP to drain and return to the dry-weather condition. For detention BMPs, drawdown time is a function of basin volume and outlet orifice size. For infiltration BMPs, drawdown time is a function of basin volume and infiltration rate.

**Flow-Based Treatment Control Measures** – Stormwater quality treatment measures that rely on flow capacity to treat stormwater. These measures remove pollutants from a moving stream of water through filtration, infiltration, adsorption, and/or biological processes. Examples: vegetated swales, media cartridge systems, and filter strips.

**Head (hydraulic head)** – In hydraulics, energy represented as a difference in elevation. In slow-flowing open systems, the difference in water surface elevation, e.g., between an inlet and outlet.

**Hydrograph** – Runoff flow rate plotted as a function of time.

**Hydrologic Soil Group** –

*TYPICAL INFILTRATION RATES*

Soil Type (Hydrologic Soil Group)	Infiltration Rate (in/hr.)
A	1.00 – 8.3
B	0.5 – 1.00
C	0.17 – 0.27
D	0.02 – 0.10
<i>Infiltration rates shown represent the range covered by multiple sources, e.g., ASCE, BASMAA, etc.</i>	

**Hydromodification** – Change in runoff characteristics from a watershed caused by changes in land use conditions<sup>2</sup> (i.e., urbanization, dam construction, etc.). Hydromodification results in an artificially altered rate of natural channel erosion and sedimentation processes.

**Illicit Connection** - Any man-made conveyance that is connected to the storm drain system without a permit, excluding roof drains and other similar type connections. Examples include channels, pipelines, conduits, inlets, or outlets that are connected directly to the storm drain system.

**Illicit Discharge** - Any discharge to the storm drain system that is prohibited under local, state, or federal statutes, ordinances, codes, or regulations. The term illicit discharge includes all non stormwater discharges except discharges pursuant to an NPDES permit, discharges that are

<sup>2</sup> NPDES No. CAS082597, Order No. R5-2008-0142, Waste Discharge Requirements, Cities of Citrus Heights, Elk Grove, Folsom, Galt, Rancho Cordova, Sacramento, and County of Sacramento, Storm Water Discharges from Municipal Separate Storm Sewer System, Sacramento County

identified as "allowable" in NPDES Municipal Stormwater Permits, and discharges authorized by the State and/ or Regional Board.

**Impervious Surface** – Any material that prevents or substantially reduces infiltration of water into the soil as would occur under natural conditions before development. Common impervious surfaces include but are not limited to roofs, walkways, patios, driveways, parking lots, areas that are paved, or other surfaces that similarly impede the natural infiltration of surface water or stormwater.

**Industrial General Permit** – The general NPDES permit adopted by the State Board which authorizes the discharge of stormwater from certain industrial activities under certain conditions.

**Infiltration** - The entry of water into the soil. Infiltration rate (or infiltration capacity) is the maximum rate at which a soil in a given condition will absorb water.

**Inspection** - Entry and the conduct of an on-site review of a facility and its operations, at reasonable times, to determine compliance with specific municipal or other legal requirements.

**Low Impact Development (LID)** - A stormwater management strategy that emphasizes conservation and use of existing natural site features integrated with distributed, small-scale stormwater controls to more closely mimic natural hydrologic patterns in residential, commercial, and industrial settings.  
- Source: Puget Sound Action Team 2005

**Maximum Extent Practicable (MEP)** – Section 402(p)(3)(B) of the Clean Water Act (CWA) directs the Regional Board to issue NPDES Municipal Stormwater Permits which require the dischargers to develop and implement programs with the goal of reducing the discharge of pollutants in stormwater runoff to the maximum extent practicable (MEP). Originally, the term was not clearly defined by the CWA or subsequent regulations, in order to allow dischargers the flexibility to design programs tailored to unique conditions and needs of the community. However, the SWRCB has since attempted to define the term. The State Board's Office of Chief Counsel (OCC) issued a memorandum interpreting the meaning of MEP to include *technical feasibility, cost, and benefit derived with the burden being on the municipality to demonstrate compliance with MEP by showing that a BMP is not technically feasible in the locality or that BMP costs would exceed any benefit to be derived* (dated 11 February 1993). For a more detailed discussion of this standard, see State Board Orders WQ 1000-11 and 91-03. Finding 38 of the Sacramento Areawide NPDES Stormwater Permit No. CAS082597 states: *Implementation of BMPs and compliance with performance standards in accordance with the Permittees' Stormwater Quality Improvement Plans and their schedules constitutes compliance with the MEP standard.*

**Municipal Separate Storm Sewer System (MS4)** - A conveyance or system of conveyances (including roads with drainage systems, municipal streets, alleys, catch basins, curbs, gutters, ditches, manmade channels, or storm drains) owned by a State, city, county, town or other public body, that is designed or used for collecting or conveying stormwater, which is not a combined sewer, and which is not part of a publicly owned treatment works, and which discharges to Waters of the United States.

**National Pollutant Discharge Elimination System (NPDES)** - The national program for issuing, modifying, revoking and reissuing, terminating, monitoring and enforcing permits under Clean Water Act §307, 402, 318, and 405.

**Natural Drainage System** - An unlined or unimproved (not engineered) creek, stream, river or similar waterway.

**New Development** - Land disturbing activities; structural development, including construction or installation of a building or structure, creation of impervious surfaces; and land subdivision.

**Non-Stormwater Discharge** - Any discharge to a storm drain that is not composed entirely of stormwater. Certain non-stormwater discharges are authorized per the NPDES Municipal Stormwater Permits.

**NPDES Municipal Stormwater Permit** – A permit issued by a Regional Water Quality Control Board to local government agencies (Dischargers) placing provisions on allowable discharges of municipal stormwater to Waters of the State.

**Open Space** - Pervious area within the project that is subtracted from the total project area to reduce the area used in sizing treatment and low impact development (LID) BMPs. For LID implementation, open space includes, but is not limited to, natural storage reservoirs, drainage corridors, buffer zones for natural water bodies, stream setbacks and buffers, and flood control detention basins.

**Performance Standard** - A narrative or measurable number specifying the minimum acceptable outcome for a pollution control practice.

**Permittees** - Agencies named in the NPDES Municipal Stormwater Permits as being responsible for permit conditions within their jurisdictions. For the Sacramento Areawide NPDES Municipal Stormwater Permit, the Permittees are the County of Sacramento and the Cities of Citrus Heights, Elk Grove, Folsom, Galt, Rancho Cordova and Sacramento.

**Permitting Agency** – The City or County responsible for issuing grading, building and encroachment permits for new and redevelopment projects. In this Manual, “permitting agency” does not refer to the regulatory agencies responsible for issuing environmental permits.

**Pollutants** - Those substances defined in CWA §502(6) (33.U.S.C. §1362(6)), and incorporated by reference into California Water Code §13373.

**Porous Pavements (Pervious pavements)** – Pavements for roadways, sidewalks, or plazas that are designed to infiltrate runoff, such as: pervious concrete, pervious asphalt, unit pavers- on-sand, and crushed gravel.

**Post-Construction Stormwater Quality Plan** – A plan specifying and documenting permanent site features and control measures that are designed to control pollutants for the life of the project. The plan should include sufficient design detail and calculations to demonstrate the adequacy of the

stormwater quality control measures to control pollution from the developed site. This plan may be required prior to issuance of certain development permits; check with your local permitting agency.

**Priority Projects** - New development and redevelopment projects that are required to incorporate appropriate post construction stormwater quality measures into the design plan for their respective project. See Table 3-2 and Table 3-3 (in Chapter 3) to determine if the project meets the size threshold that triggers the requirements, and to see which specific requirements apply.

**Rain Event or Storm Event** - Any rain event greater than 0.1 inch in 24 hours except where specifically stated otherwise.

**Rational Method** – A method of calculating runoff flows based on rainfall intensity, and contributing drainage area, and a factor representing the proportion of rainfall that runs off.

**Receiving Waters** - All surface water bodies in the Central Valley Region that are identified in the Basin Plan.

**Regional Stormwater Quality Treatment Facility (Regional Facility)** – A facility that treats runoff from more than one project or parcel (typically a large drainage catchment of 100 acres or more). A regional facility may be in lieu of on-site treatment controls to treat urban runoff prior to discharge to Waters of the State, subject to the approval of the applicable permitting agency.

**Regional Water Quality Control Board (RWQCB)** – California RWQCBs are responsible for implementing pollution control provisions of the Clean Water Act and California Water Code within their jurisdiction. There are nine California RWQCBs. Sacramento County areas are under the jurisdiction of the Central Valley RWQCB (Region 5; a.k.a. the Regional Water Board).

**Restaurant** - A facility that sells prepared foods and drinks for consumption, including stationary lunch counters and refreshment stands selling prepared foods and drinks for immediate consumption (SIC Code 5812).

**Retail Gasoline Outlet** - Any facility engaged in selling motor vehicle fuels and lubricating oils.

**Retention** – The practice of holding stormwater in ponds or basins and allowing it to slowly infiltrate to groundwater. Some portion will evaporate. Also see infiltration.

**Sacramento Stormwater Quality Partnership** – A collaborative of public agencies in Sacramento County that protects and improves water quality in local waterways for the benefit of the community and the environment. Participating agencies include the County of Sacramento and the Cities of Citrus Heights, Elk Grove, Folsom, Galt, Rancho Cordova and Sacramento.

**Significant Redevelopment** - Land-disturbing activities on an already developed site (see Table 3-3). Includes, but is not limited to: expansion of a building footprint; replacement of a structure; replacement of impervious surface that is not part of routine maintenance activity; and land-disturbing activities related to structural or impervious surfaces. Replacement of impervious surfaces includes any activity where impervious materials are removed, exposing underlying soil during



construction. For redevelopment projects subject to this manual, the applicable design standards apply only to the redeveloped area, and not to the entire site, except in cases where untreated drainage from the existing developed portion is allowed to enter/flow through the redeveloped portion. In such cases, any new required treatment control measures must be designed for the entire contributing drainage area. Redevelopment and infill project applicants should check with the local permitting agency at the start of project design to verify whether or not the manual requirements apply.

**Source Control Measure** - Any schedules of activities, prohibitions of practices, maintenance procedures, managerial practices or operational practices that aim to prevent stormwater pollution by reducing the potential for contamination at the source of pollution.

**Stormwater** - Stormwater runoff, snowmelt runoff, and surface runoff and drainage.

**Structural Control Measure** - Any structural facility designed and constructed to mitigate the adverse impacts of stormwater and urban runoff pollution (e.g. canopy, structural enclosure). The category may include both source and treatment control measures.

**Target Pollutants** – Pollutants identified by the Permittees as most likely to impair local receiving waters, based on evaluation of available monitoring data and other information.

**Treatment** - The application of engineered systems that use physical, chemical, or biological processes to remove pollutants. Such processes include, but are not limited to, filtration, gravity settling, media absorption, biodegradation, biological uptake, chemical oxidation, and UV radiation.

**Treatment Control Measure** - Any engineered system designed to remove pollutants by simple gravity settling of particulate pollutants, filtration, biological uptake, media absorption or any other physical, biological, or chemical process.

**Urban Runoff** - Any runoff from urbanized areas that enters the MS4 including stormwater and dry weather flows from a drainage area that reaches a receiving water body or subsurface. During dry weather, urban runoff may be comprised of groundwater base flow and/or nuisance flows, such as excess irrigation water.

**Volume-Based Treatment Control Measures** – Stormwater quality treatment measures that rely on volume capacity to treat stormwater. These measures detain or retain runoff and treat it primarily through settling or infiltration. Examples: detention and infiltration basins, porous pavement and bioretention planters.

**Water Board(s)** – Generic reference to the State Water Resources Control Board (SWRCB) and/or the nine Regional Water Quality Control Boards (RWQCBs).

**Water Quality Volume (WQV)** – For stormwater treatment BMPs that depend on detention to work, the volume of water that must be detained to achieve maximum extent practicable pollutant removal. This volume of water must be detained for a specified drawdown time.

## Glossary

**Watershed** – That geographical area that drains to a specified point on a water course, usually a confluence of streams or rivers (also known as drainage area, catchment, or river basin).

**Wet Season (Rainy Season)** – For the Sacramento region, the calendar period beginning October 1 and ending April 15. *Note: This differs from the CA Dept. of Fish and Wildlife wet weather definition, which is October 15 – April 15.*

# Chapter 1. Introduction

---

## Purpose

This *Stormwater Quality Design Manual for the Sacramento Region* (manual) outlines planning tools and requirements to reduce urban runoff pollution to the maximum extent practicable (MEP) from new development and redevelopment projects.

This manual is a collaborative effort of the Sacramento Stormwater Quality Partnership<sup>1</sup> and is intended to satisfy the regulatory requirements of their respective municipal stormwater permits. (See the section *Background Information* later in this chapter for more about the Partnership and permit requirements.)

## Goals

The Sacramento permitting agencies have the following goals for this manual:

- Protect the quality of our local creeks and rivers.
- Consolidate all stormwater quality design requirements into one document.
- Provide a consistent set of requirements for stormwater quality management that apply in the urbanized part of Sacramento County; this is intended to facilitate better area-wide compliance with clean water laws.
- Promote the consideration of stormwater management early in the site planning and project design process; the optimal, most cost-effective approach often involves integrating stormwater controls into overall site design.
- Provide tools and criteria (including maintenance and construction considerations) for selecting and designing a range of stormwater quality control measures.
- Incorporate recommendations of the local vector control districts so that stormwater quality control facilities do not create mosquito breeding habitat.

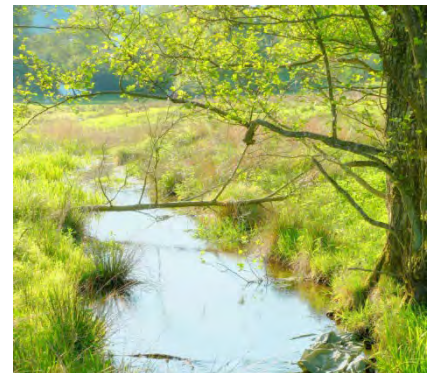

*The stormwater quality development standards are intended to protect our valuable creek and river resources for future generations.*

*Photo source: Shutterstock.com*

---

### *This Design Manual*

*This comprehensive manual outlines a consistent set of stormwater quality management design standards for many new and redevelopment projects in the urbanized parts of Sacramento County. It provides planning and design tools for use by planners, architects, landscape architects, engineers, and environmental professionals.*

---

---

<sup>1</sup> The Sacramento Stormwater Quality Partnership includes the County of Sacramento and the Cities of Citrus Heights, Elk Grove, Folsom, Galt, Rancho Cordova and Sacramento. For more information, see the Glossary.

## Background Information

Under the federal Clean Water Act, stormwater discharges are regulated through National Pollutant Discharge Elimination System (NPDES) Municipal Stormwater Permits. In California, the State Water Board and its nine Regional Boards oversee implementation of the Clean Water Act, and the Central Valley Regional Water Quality Board (Regional Board) issues and enforces NPDES stormwater permits and the State water quality law, Porter – Cologne, within the Central Valley. Phase I NPDES permits have been issued to municipalities with a population greater than 100,000 (and certain industries and construction projects) since 1990. The Regional Board began issuing Phase II NPDES general permits to smaller municipalities in 2003. Municipal stormwater permits require municipalities to regulate and manage the quality of urban runoff throughout their jurisdictions, including runoff from new development and significant redevelopment projects.

### Sacramento Areawide Stormwater Permit Requirements

The Sacramento Areawide NPDES Municipal Stormwater Permit is a Phase I permit and applies to the County of Sacramento along with the Cities of Citrus Heights, Elk Grove, Folsom, Galt, Rancho Cordova and Sacramento. Originally issued in 1990, the Sacramento stormwater permit has been reissued several times. The most recent permit (NPDES Permit No. CAS082597) was adopted in December 2002, reissued in September 2008, and reissued again in April 2015. The Central Valley Water Board replaced it with a Region-wide MS4 Permit in June 2016. The Permittees function independently on many tasks, including reviewing, processing and permitting plans for new development and redevelopment in their respective jurisdictions. However, they work together on other tasks and projects, such as the creation of this manual. This manual is an outgrowth of prior steps taken to comply with the municipal stormwater permit.

The Permittees (collectively referred to as the Sacramento Stormwater Quality Partnership, or Partnership) began conditioning development projects in Sacramento County to include stormwater quality control measures in the mid 1990's. The City and County of Sacramento published the *Guidance Manual for On-Site Stormwater Quality Control Measures* in January 2000; that document was widely referenced by all the Permittees and has since been replaced by this manual.

---

*This manual is the second edition of the Stormwater Quality Design Manual for the Sacramento Region, replacing the May 2007 version.*

---

In July 2003, the Permittees published their Stormwater Quality Improvement Plans, which described their comprehensive program to comply with their municipal stormwater permit and reduce pollutants in urban runoff to the maximum extent practicable. The New Development program element of the plans called for an assessment of existing development standards and amendment/adoption of new standards as needed to better address the permit. (As used here, the term “development standards” collectively refers to the policies, ordinances, codes and design standards established and enforced by each of the permitting agencies.)

In December 2003, the Partnership submitted a Development Standards Plan (DSP) to the Regional Board; the DSP assessed the existing development standards (as of 2003) and proposed actions that

would be taken to amend the standards within one year of approval of the DSP. The Regional Board officially approved the DSP on May 18, 2005 and gave the Permittees until May 18, 2006 to complete the process of amending/adopting new standards. According to the municipal stormwater permit, the Permittees had until May 18, 2007 to publish technical design guidelines to help the development community understand and implement the new standards. The required technical guidance was initially developed in the 2007 version of this manual. The 2018 version of the manual expands upon the 2007 version to address more prescriptive LID requirements, new hydromodification management requirements, and full capture trash requirements, as required in the 2016 MS4 General Permit.

The DSP affected the types of projects subject to this manual. The Sacramento municipal stormwater permit specifies different categories of new development and redevelopment projects that are subject to development standards related to stormwater quality management. Some of the categories and corresponding thresholds specified in the stormwater permit were effectively modified when the Regional Board approved the DSP in May 2005. Those changes are reflected in this manual (Table 1-2, Table 3-2 and Table 3-3).

### Agency Collaboration in Developing this Manual

This manual is the result of a collaborative planning effort by a steering committee comprised of managers and staff from the following agencies:

- County of Sacramento, Department of Water Resources
- City of Rancho Cordova, Department of Public Works
- City of Sacramento, Department of Utilities
- City of Citrus Heights, General Services Department, Engineering Division
- City of Elk Grove, Department of Development Services/Public Works
- City of Folsom, Department of Public Works
- City of Galt, Department of Public Works

In addition, the local vector control districts were consulted, since several types of stormwater quality control measures could have the potential to support mosquito breeding habitat, if not properly designed, constructed and maintained. Other contributors included local sanitation districts, fire departments and districts and solid waste interests.

## Using the Manual

### Intended Audience

This manual is primarily intended for people involved in the design or review/approval of development projects. Table 1-1 lists the different professionals who typically should be involved at each phase of a project. It is important to involve many different design professionals early in the planning process when the initial site layout is determined. It is equally important that those involved in site planning and design work collaboratively throughout the site design process; that way,

stormwater quality features can be optimally integrated into the site and project design. Benefits of the collaborative team approach and strategies for involving everyone throughout the process are discussed more in Chapter 2, **Integrated Approach to Stormwater Management**.

The manual also contains some information related to construction and maintenance of stormwater quality facilities; therefore, it may be used by contractors, inspectors, property owners and others as shown in Table 1-1.

Finally, the manual may be used by developers, elected and appointed public agency officials, environmental regulatory agencies and interested citizens.

### Projects Covered by the Manual

Table 1-2 lists the types of projects and land uses generally addressed by this manual. If a project falls into one of those categories, see Table 3-2 and Table 3-3 (in Chapter 3, **Steps to Managing Stormwater Quality**) to see if the project meets the size threshold that triggers the requirements and, if so, to see which specific requirements apply.

Development projects potentially subject to this manual include both new development as well as "significant redevelopment" projects. Significant redevelopment means land-disturbing activities on an already developed site. It includes but not limited to: expansion of a building footprint; replacement of a structure; replacement of impervious surface that is not part of routine maintenance activity; and land-disturbing activities related to structural or impervious surfaces.

For redevelopment projects subject to this manual, the applicable design standards apply only to the redeveloped area, and not to the entire site, except in cases where untreated drainage from the existing developed portion is allowed to enter/flow through the redeveloped portion. In such cases, any new required treatment control measures must be designed for the entire contributing drainage area. Redevelopment and infill project applicants should check with the local permitting agency at the start of project design to verify whether or not the manual requirements apply.

Table 1-1 Applying the Design Manual to Every Phase of Development

Project Phase	Typical Decisions/Activities	Professionals Involved
Initial site layout and planning	Building and parking footprints; site access; preservation/integration of existing natural resource features (trees and other vegetation, creek buffers, wetlands, vernal pools, open space); use of natural or existing depressions for siting certain stormwater quality features; identification of existing sewer and drainage facilities; preliminary on-site soils testing to determine which stormwater quality features will work on the site	Architects; planners; environmental consultants; geotechnical and drainage engineers; landscape architects; arborists; and permitting agency planning and engineering staff (initial consultations and pre-application meetings)
Site improvement design	Site contouring and grading; on-site drainage and connections to municipal system; other utilities (sanitary sewer, water, power); pavement selection for parking, roads and walkways	Civil and other engineers; landscape architects; permitting agency plan review staff (drainage engineers, traffic, fire, etc.)
Building design	Final building footprint; building access; roof type and materials; roof drainage/downspout system; location/type water features (e.g., ponds, waterfalls, fountains); location of landscaping around the building (and possibly selection of vegetation type/style to complement building design or provide consistency with existing vegetation to be preserved on site or in the surrounding area)	Architects; civil/structural, geotechnical and other engineers as appropriate
Landscape and irrigation design	Final selection of type of trees and other vegetation; final contouring of landscaped areas; installation of vegetation and bark/other ground cover materials; design and installation of irrigation system; construction of water features	Landscape architects; municipal arborists; wetland specialists/biologists if applicable
Construction	Installation of stormwater quality facilities; installation of erosion and sediment control measures to protect the facilities from receiving high sediment loads during construction process; final clean-out and preparation of stormwater facilities prior to permitting agency acceptance	Contractors; erosion control specialists; permitting agency inspectors
Maintenance	Building, grounds and landscape maintenance, including maintenance of vegetated stormwater quality facilities (mowing, watering schedule, application of fertilizers, herbicides and insecticides, replacing/repairing damaged vegetation and eroded areas)	Property owners and managers; maintenance and landscape contractors; permitting agency maintenance staff

Table 1-2 Types of Projects Addressed by This Manual

Priority Project Category <sup>2</sup>	Description
Single Family Residential	In general, this category includes detached single-family homes and duplexes. Check with local permitting agency for verification.
Multi-Family Residential	In general, this category includes attached single-family homes (except duplexes), condominiums, townhomes, and apartments. Check with local permitting agency for verification.
Commercial and Light Industrial	Development on private land that is not for heavy industrial or residential uses. This category includes, but is not limited to, hospitals, laboratories and other medical facilities, educational institutions, churches, recreational facilities, parks, commercial nurseries, car wash facilities, mini-malls and other business complexes, shopping malls, hotels, office buildings, public warehouses, kennels, equipment rental facilities, and other light industrial facilities.
Automotive Repair Shops	A facility that is categorized by one of the following Standard Industrial Classification (SIC) codes: 5013, 5014, 7532-7534, or 7536-7539.
Retail Gasoline Outlets	Any facility engaged in selling motor vehicle fuels and categorized by Standard Industrial Classification (SIC) code 5541.
Restaurants	Any facility that sells prepared foods and drinks for consumption, including stationary lunch counters and refreshment stands selling prepared foods and drinks for immediate consumption (SIC code 5812).
Hillside Developments	Any development in an area with known erosive soil located in an area with natural slopes having a twenty-five percent or greater grade.
Parking Lots	All or portion of parking lots exposed to rainfall (uncovered impervious area) for the temporary parking or storage of motor vehicles used personally, for business, or for commerce.
Streets/Roads	Any paved surface used by automobiles, trucks, motorcycles, and other vehicles.
Heavy Industrial	Heavy industrial facilities (light industry covered under commercial category)
<p><sup>1</sup> Thresholds for determining which types of stormwater quality measures apply to each project type can be found in Table 3-2 and Table 3-3 in Chapter 3, Steps to Managing Stormwater Quality.</p> <p><sup>2</sup> Refer to applicable permitting agency's zoning definitions.</p>	

## How the Manual is Organized

**Chapter 1** provides an introduction.

**Chapter 2** explains the benefits of integrating stormwater quality management into overall project design and describes strategies and principles for doing so.



**Chapter 3** outlines a step-by-step process for fulfilling the requirements of this manual and references the other chapters for more information.

**Chapter 4 and Chapter 5** provide specific siting and design criteria (as well as construction and maintenance considerations) for a range of stormwater quality control measures. Chapter 4 covers source controls; Chapter 5 covers hydromodification control measures, low impact development measures, and treatment controls.

**Chapter 6** provides guidance for design of green streets for municipal projects, as well as incorporation of associated LID design elements.

**The Appendices** provide additional detail on a number of topics. In addition:

- Appendix C lists permitting and contact information related to discharges to the sanitary sewer; that is included since some source control measures call for discharging potentially polluted site runoff to the sanitary sewer.
- Appendix F lists sources for stormwater management information not covered by this manual (as described in the next section).

---

*CASQA's "California BMP Handbook for Development" was referenced in the creation of this Design Manual, with many adaptations made for the Sacramento Region. In the event of conflicts between this manual and the CASQA handbook, this manual will generally take precedence. Contact your local permitting agency for clarification.*

---

Reference materials used to develop each chapter are listed at the end of that chapter, and references used to develop the various control measure fact sheets are presented at the end of each fact sheet in Chapter 4 and Chapter 5. The two main reference documents were the *Stormwater Quality Design Manual for the Sacramento and South Placer Regions* (May 2007) and the California Stormwater Quality Association's statewide document, *California Storm Water Best Management Practice Handbook for New Development and Redevelopment* (January 2003, revised September 2004). Also referenced were the *Sacramento Stormwater Quality Partnership Hydromodification Management Plan* (July 29, 2011, revised February 14, 2013) and the *Low Impact Development Standards Development, Stormwater Quality Design Manual Update and BMP Sizing Tool Enhancement – Task 1: Develop Low Impact Development (LID) Standards for New Development and Redevelopment Projects and Associated Work Report* (June 23, 2012).

### Stormwater Management Information Not in this Manual

This manual does not include:

- Drainage/flood control design standards
- Temporary erosion and sediment controls and other pollution controls used during construction activities
- On-going operational practices to control pollution at industrial and commercial facilities once they are constructed (such as making sure employees don't dump hazardous or liquid wastes in the trash).

## Chapter 1: Introduction

For information about those topics, see the references listed in Appendix F.

### Obtaining the Manual and Updates

Go to [www.beriverfriendly.net](http://www.beriverfriendly.net) to download this manual (PDF format) and obtain information for ordering a hard copy.

The manual will be updated periodically to reflect new information. To determine if updated information or errata sheets are available, check [www.beriverfriendly.net](http://www.beriverfriendly.net) regularly or contact one of the local permitting agencies listed in the front of this manual.

### Questions and Comments

We welcome your questions and comments and will also consider this information in making future updates and improvements.

For information related to projects in Sacramento County, contact the appropriate permitting agency listed at [www.beriverfriendly.net](http://www.beriverfriendly.net) (new development).

Send questions and comments on the design manual to: [dfadl@cityofsacramento.org](mailto:dfadl@cityofsacramento.org) with “stormwater design manual” in the subject line.

# Chapter 2. Integrated Approach to Stormwater Management

---

## Integrated Planning and Design Approach

In order for site designs to reflect the best stormwater management strategies, it is essential that stormwater be considered early in the site design process—before the site layout is established. Otherwise, the choice/location of stormwater controls will be constrained by prior site design decisions (e.g., predetermined grading contours), and may be limited to more expensive, higher-maintenance, and less aesthetically pleasing options.

When stormwater controls are considered early, they can be effectively integrated into site design and planning. There are often opportunities to use existing or proposed site features for stormwater controls and/or repeat small-scale stormwater controls over an entire site. Small-scale controls are typically low-cost and cumulatively very effective.

In some cases, site design necessitates trade-offs among competing goals; however, especially when considered early in the process, stormwater goals can often complement other goals and agency requirements, including those related to vegetation preservation, landscaping, aesthetics, open space, recreational areas, and/or habitat.

## Benefits of the Integrated Approach

### Benefits to the Property Owner/Developer

Stormwater quality features that are integrated into the fabric of a community, designed to be aesthetically pleasing and provide recreational opportunities and/or aquatic habitat may increase property values. Property values at a subdivision built in the 1970's in Davis, California (Village Homes) have been reported to be higher than those of comparable homes in nearby conventionally-designed subdivisions (*Start at the Source*). This community was designed with seasonal vegetated swales in place of storm drain pipes, community open space, a downstream constructed wetland (the West Davis Pond) and other environmental features.

### Environmental Benefits

There are various environmental benefits that can be achieved by protecting natural features, maintaining pre-developed drainage patterns, and/or integrating stormwater quality features into site design:

- Cleaner and cooler runoff delivered to local creeks and rivers

- Cleaner and cooler air due to protected and/or added trees and other vegetation and reduced impervious surfaces
- Protected, and/or added habitat for birds, fish and other wildlife
- Improved water quality by reducing channel erosion

### Community Benefits

Well-designed stormwater quality facilities can add value to a community or business setting and improve the quality of life for residents and tenants. Whether or not these features are viewed as an asset depends in large part on how they are incorporated into the overall development project. When small-scale local stormwater controls are considered at the very beginning of the design process, there are more opportunities to integrate them into landscaping as attractive amenities rather than placing them underground. In the right setting, when stormwater quality facilities can be seen and appreciated and their function is explained to residents and tenants, they may foster a natural resource stewardship ethic. Also, landscape-based features, especially those designed using native and drought-tolerant plants, can have less intensive maintenance needs than underground devices.

Similarly, larger-scale regional facilities such as water quality detention basins can be designed to provide tremendous benefits when these are considered early in the process; they can be featured prominently as an attractive amenity and community resource with passive recreation benefits. When such facilities are placed behind residents' backyards or in a forgotten fenced-off corner of the development, the community benefits are lost.

## Strategies for Effectively Integrating Stormwater Quality Management into Project Design

### Assemble a Collaborative Team Early

In order for site designs to reflect the best stormwater management strategies, stormwater controls must be considered early in the site design process. To do that, involve the project engineer and other design professionals during the conceptual design stage, when the initial site layout is being determined. In the past, only planners and architects may have been involved at this stage of the design.

The collaborative design process may involve the following key players:

- Project Owner
- Permitting Agency Staff
- Planners
- Architects
- Engineers (Civil, Geotechnical)
- Landscape Architects
- Arborists
- Environmental Consultants

Table 1-1 in Chapter 1 indicated the various roles that each of these individuals can play in each phase of the planning and design work.

It is also helpful to arrange a meeting with the local permitting agency to get agency input at the conceptual design stage; in most jurisdictions, this is referred to as the pre-application meeting.

It is equally important that those involved in site planning and design work collaborate throughout the site design process; that way, stormwater quality features can be optimally integrated into the site and project design. This might be facilitated by periodic meetings of the project team and by routing various designs to the different disciplines for review and comment.

### Consider the Site and its Surroundings

Gather information about the following site characteristics, which will greatly influence the type of stormwater quality controls used on your project:

- **Existing natural hydrologic features** and natural resources, including any contiguous natural areas, wetlands, watercourses, seeps, or springs.
- **Existing site topography**, including contours of any slopes of 4% or steeper, general direction of surface drainage, local high or low points or depressions, and any outcrops or other significant geologic features.
- **Zoning**, including requirements for setbacks and open space.
- **Soil types** (including hydrologic soil groups) and depth to groundwater, which may determine whether infiltration is a feasible option for managing site runoff. A preliminary determination of infiltration feasibility may be made using maps in hydrology and flood control design manuals published by the local permitting agency. Also, site-specific information (e.g. from boring logs or geotechnical studies) may be required by the permitting agency, depending on the site location and characteristics.
- **Existing site drainage**. For undeveloped sites, determine drainage patterns by inspecting the site and examining topographic maps and survey data. For previously developed sites, locate site drainage and connections to the municipal storm drain system from a site inspection, municipal storm drain maps, and/or the approved plans for the existing development (typically on file with the local municipality).
- **Existing vegetative cover** and impervious areas, if any.
- **Existing trees** and arborists report, if any.

### Identify Opportunities and Constraints

Using the site features information gathered above, identify the principal opportunities and constraints for stormwater quality management on the site.

**Opportunities** might include existing natural areas, low (depressed) areas, oddly configured or otherwise un-developable parcels, easements, and open space (which potentially can double as locations for stormwater quality controls with the permitting agency's approval). Also look at elevation differences on the site which might provide hydraulic head for structural treatment control measures.

**Constraints** might include impermeable soils, high groundwater, contaminated soils or groundwater, steep slopes, geotechnical instability, existing utilities, high intensity land use, expected heavy pedestrian or vehicular traffic, safety concerns, or compatibility with surrounding land uses. Also there might be competing environmental concerns on the project site.

### Preserve Valuable Site Features

Consider these techniques to preserve natural and environmentally-sensitive features on your site:

- Define development envelope and protected areas, identifying areas that are most suitable for development and areas that should be left undisturbed.
- Cluster the development to conserve natural areas and provide open space for the new residents/tenants to enjoy.
- Preserve natural vegetation. Vegetation is an integral part of the natural hydrologic cycle. Vegetation intercepts rainfall, and plant roots take up water that soaks into the ground. Also, roots and decaying organic matter such as leaf litter protect the soil structure and soil permeability, and therefore help preserve the pollutant-removal processes that occur in soil. When designing a site, retain as much natural vegetation as possible.
- Consider preserving trees (consider the number, quality and health and location of existing trees), even if the local jurisdiction would allow their removal, for all the reasons given above.
- Set back the development from creeks, wetlands, and riparian habitats. Check with the local agency regarding minimum setback requirements.
- Designate and protect natural buffers for waterways and natural areas. If disturbing buffer areas during construction is unavoidable, make plans to replant them with plants and trees adapted and suited to the site conditions, preferably low-water use plants. Such plants have a better chance of survival and adaptation to the site over time without an over reliance on water and fertilizers/pesticides.

### Lay Out the Site with Topography and Soils in Mind

To minimize stormwater-related impacts, consider applying the following design principles to the site layout:

- Choose a design that replicates the site's natural drainage patterns as much as possible.
- Where possible, conform the site layout to natural landforms.
- Identify topographic lows that might be suitable for locating stormwater quality treatment features.
- Concentrate development on portions of the site with less permeable soils and preserve areas that will actively promote infiltration.
- When possible, avoid disturbing steep slopes and erodible soils.
- When possible, avoid excessive grading and disturbance of vegetation and soils.
- When possible, avoid the use of closed conduit systems.
- When possible, avoid compacting soils in open and/ or landscape areas.

## Put Landscaping to Work

All permitting agencies require landscaping for most development projects, for both aesthetic and shading purposes, and sometimes for noise reduction. Stormwater quality features can often be integrated into landscape areas such as the site perimeter, parking medians, and roadside areas. For example, instead of mounding the landscaped areas in a business center parking lot, consider creating depressed areas (i.e. bioretention, swales) to accept and filter the water before sending it off the site. Using landscape areas for stormwater quality features may require some changes in the conventional approach to landscape designs, and may result in larger/wider landscape areas. Check with your local permitting agency regarding specific landscaping and tree requirements and related requirements such as water conservation. Additional information can be found in Chapter 4, **Source Control Measures**, at [www.beriverfriendly.net](http://www.beriverfriendly.net) and the State's Department of Water Resources Model Water Efficient Landscape Ordinance AB 1881.

## Stop Pollution at Its Source

Rather than managing stormwater runoff only at the final point of discharge from a site, look for opportunities to manage pollution where it is first generated. Source control measures keep pollutants from entering stormwater to begin with, whereas treatment control measures remove pollutants from stormwater runoff. Chapter 4, **Source Control Measures** presents a variety of source controls for new development and redevelopment, such as:

- Marking storm drain inlets with “No Dumping” messages to deter illegal dumping.
- Locating and designing outdoor trash enclosure areas so that polluted runoff from these areas does not enter the storm drain system.
- Designing vehicle wash areas so that soapy, polluted water is not delivered to the storm drain system.

Specific source controls are required for various types of development projects (see **Table 3-3** in Chapter 3, **Steps to Managing Stormwater Quality**), but also look for additional ways to stop pollution at the source.

## Reduce Runoff Close to Its Source

Another way to stop pollution at its source is to reduce runoff wherever possible through the incorporation of low impact development (LID) measures. Reducing site runoff will also reduce the volume and duration of flows to local creeks, thus reducing the potential for downstream erosion and habitat impairment. LID measures are required for all projects. LID measures can reduce project costs for projects that typically require runoff treatment because this can reduce the need for stormwater quality treatment.

The main ways to reduce runoff are to promote infiltration, minimize impervious surfaces, disconnect impervious surfaces (disconnecting impervious surfaces means to intercept the runoff by draining the roof or pavement to a pervious area and not directly to the storm drain system), and promote planting of trees and shrubs to intercept and slow the runoff.

### *Promote Infiltration Where Feasible*

On undeveloped, undisturbed land, rain slowly percolates into the soil and impurities are filtered out and transformed through natural biological processes. When designing a site, look for ways to promote infiltration and allow soil to filter and naturally transform impurities. For example, consider dispersing runoff over a landscaped area. Of course, infiltration is not appropriate where it would pose a threat to groundwater quality or cause other problems such as destabilizing a site.

As part of an amended soil layer, proper mulch can also have a measurable benefit in promoting infiltration by supporting a healthy soil, trapping moisture, and slowing the runoff. Select shredded mulches that are non-floating. Per Order No. R4-2012-0175, "Aged mulch, also called compost mulch, reduces the ability of weeds to establish, keeps soil moist, and replenishes soil nutrients. Aged mulch can be obtained through soil suppliers or directly from commercial recycling yards. It is recommended to apply 1 inch to 2 inches of composted mulch, once a year, preferably in June following weeding."

Consider infiltration stormwater quality treatment control measures for your site where feasible. Chapter 5, **Hydromodification Management, Low Impact Development, and Treatment Control Measures** includes design information for two such devices: the infiltration basin and infiltration trench.

### *Minimize Impervious Surfaces*

For all types of development, try to limit overall coverage of paving and roofs. This can be accomplished—where consistent with local zoning regulations and development standards—by designing compact, taller structures, narrower and shorter streets and sidewalks, smaller parking lots (fewer/smaller stalls where possible, and more efficient lanes), and indoor or underground parking. Examine site layout and circulation patterns and identify areas where landscaping, porous pavement, or planter boxes can be substituted for pavement.

### *Where Feasible, Avoid Draining Impervious Areas Directly to a Storm Drain*

When the built and landscaped areas are defined on your site drawings, look for opportunities to minimize impervious areas that are directly connected to the storm drain system. Chapter 5 presents information on several options that can be considered for this, including:

- **Direct runoff from impervious areas** to adjacent pervious areas or depressed landscaped areas.
- **Select porous pavements and surface treatments.** Inventory paved areas on the preliminary site plan and identify locations where permeable pavements, such as crushed aggregate, turf block, or unit pavers can be substituted for conventional concrete or asphalt paving. Typically, these materials work best in low-traffic parking areas, rather than high-traffic areas such as drive aisles.

Chapter 5 describes how to quantify the benefits achieved by your design decisions to reduce paved and roofed areas, to create landscaped areas and pervious pavements which retain water, and to direct runoff from impervious to pervious areas.



## Treat Runoff

Treating runoff is required for projects above certain size thresholds (which vary with respect to project category -- see Table 3-2 and Table 3-3. As previously noted, providing LID measures can reduce or possibly even eliminate the required treatment.

Treatment is accomplished by either detaining runoff long enough for pollutants to settle out or by filtering runoff through sand, soil, engineered media, or soil matrix. Typically, the limiting design factors will be available space, available hydraulic head (difference in water surface elevation between inflow and outflow), and soil permeability. In some cases, a small adjustment of elevations within the site plan can make a particular treatment option feasible and cost effective.

When developing a drainage and treatment strategy, also consider whether to route most or all drainage through a single detention and treatment control measure or to disperse smaller control measures throughout the site. Directing runoff to a single treatment area may be simpler and easier to design, but designs that integrate smaller techniques such as swales, small landscaped areas, and planter boxes throughout the site are typically more cost-effective, less maintenance intensive, and more attractive. Chapter 5, **Hydromodification Management, Low Impact Development, and Treatment Control Measures** describes various treatment control measures that are acceptable for use in the Sacramento region, such as:

- Three types of water quality detention basins (dry, wet and combination)
- Underground wet vaults or tanks
- Infiltration basin and trench
- Sand filter
- Bioretention planter
- Vegetated swale and filter strip

## Hydromodification Management

Urbanization will often cause an increase in peak flow as well as runoff duration. These increases can artificially accelerate erosion and sedimentation within receiving waters. Hydromodification control measures should be provided (as required) to mitigate this effect. These measures function through attenuation, infiltration, and dispersion of runoff. Chapter 5 includes more detailed information regarding the applicability of hydromodification management and the implementation of hydromodification management measures. Refer to the Sacramento Stormwater Quality Partnership Hydromodification Management Plan, Figure 5-1 Hydromodification Mitigation Applicability Flow Chart, and Figure 5-2 Applicability Map.

## References

- Bay Area Stormwater Management Agencies Association, *Start at the Source: Design Guidance Manual for Stormwater Quality Protection*, 1999. [www.scvurppp-w2k.com/pdfs/0910/StartAtTheSource.pdf](http://www.scvurppp-w2k.com/pdfs/0910/StartAtTheSource.pdf)
- Bay Area Stormwater Management Agencies Association, *Using Site Design Techniques to Meet Development Standards for Stormwater Quality: A Companion Document to Start at the*

Source, May 2003. [https://www.suisun.com/?dl\\_name=Stormwater-Using-Site-Design-Techniques.pdf](https://www.suisun.com/?dl_name=Stormwater-Using-Site-Design-Techniques.pdf)

- California Stormwater Quality Association, *California Storm Water Best Management Practice Handbook for New Development and Redevelopment*, January 2003 (revised September 2004). <http://www.cabmphandbooks.com>
- Prince George's County, Maryland, Dept. of Environmental Resources, *Low Impact Development Design Strategies: An Integrated Design Approach*, June 1999. <http://www.epa.gov/owow/nps/lidnatl.pdf>

## Additional Resources

- Alameda Countywide Clean Water Program. <http://cleanwaterprogram.org/index.php>
- Barr Engineering for Metropolitan Council of Governments (Minneapolis/St. Paul), *Urban Small Sites Best Management Practice Manual*, July 2001. <https://metro council.org/Wastewater-Water/Planning/Water-Resources-Management/Water-Quality-Management-Key-Roles.aspx>
- Center for Watershed Protection (Tom Schueler), *Site Planning for Urban Stream Protection*, 1995.
- Natural Resources Defense Council, *Stormwater Strategies: Community Responses to Runoff Pollution*, Chapter 12 – Low Impact Development, October 2001. [https://www.waterboards.ca.gov/rwqcb2/water\\_issues/programs/stormwater/muni/nrdc/14%20stormwater%20strategies.pdf](https://www.waterboards.ca.gov/rwqcb2/water_issues/programs/stormwater/muni/nrdc/14%20stormwater%20strategies.pdf)
- San Diego County, *County of San Diego BMP Design Manual*, 2016. [http://www.sandiegocounty.gov/content/sdc/dpw/watersheds/DevelopmentandConstruction/BMP\\_Design\\_Manual.html](http://www.sandiegocounty.gov/content/sdc/dpw/watersheds/DevelopmentandConstruction/BMP_Design_Manual.html)
- San Francisco Public Utilities Commission, *San Francisco Stormwater Management Requirements and Design Guidelines*, 2016. <http://sfwater.org/index.aspx?page=1007>

# Chapter 3. Steps to Managing Stormwater Quality

---

This chapter outlines steps to select and design stormwater quality features in order to effectively incorporate stormwater management into site design and satisfy the requirements of the permitting agencies in Sacramento County.

Figure 3-1 illustrates the process. As you proceed through the process, record project information and decisions and compile this information for submittal with the planning application and/or post-construction stormwater quality plan, described in Appendix A. Check with the local permitting agency before you begin, since they may require or recommend the use of special checklists, forms or formats for these submittals.

As explained in Chapter 2, **Integrated Approach to Stormwater Management**, developing optimal stormwater control strategies requires that stormwater be considered early in the site design process – before the site layout is established. Otherwise, the choice/location of stormwater controls will be constrained by prior site design decisions and it may not be possible to integrate stormwater controls throughout the project design. See Chapter 2 for more information about the integrated approach to effective stormwater management.

The steps outlined in this chapter are presented in sequence, but steps 3 through 7 are interrelated. Be sure to involve the engineers and other design professionals early during the conceptual design stage using the collaborative team approach discussed in Chapter 2.

## Step 1. Gather Project and Site Information

Start by compiling information about the site and project. Some local development permitting agencies (e.g., Sacramento County) will require this information to be submitted with the initial planning application:

- Project gross area (acres)
- Proposed project net area (acres): this is the gross area minus protected open space (including stream setbacks and buffers) and planned parks
- Proposed project density for residential projects (dwelling units per net area)
- Existing and proposed impervious area (acres)
- Name of watershed/receiving water and whether the project discharges directly to this receiving water or first to the municipal storm drain system
- Arborist's report

Project category and associated potential pollutants, based on Table 3-1. Pollutant information will be used later to determine appropriate control measures for your project.

Table 3-1 Project Categories and Associated Potential Pollutants

Priority Project Categories	General Pollutant Categories								
	Bacteria	Heavy Metals	Nutrients	Pesticides	Organic Compounds	Sediments	Trash & Debris	Oxygen Demanding Substances	Oil & Grease
Detached Residential Development	X		X	X		X	X	X	X
Attached Residential Development	P		X	X		X	X	p <sup>(1)</sup>	p <sup>(2)</sup>
Commercial/Industrial Development	p <sup>(3)</sup>		p <sup>(1)</sup>	p <sup>(5)</sup>	p <sup>(2)</sup>	p <sup>(1)</sup>	X	p <sup>(5)</sup>	X
Automotive Repair Shops		X			X <sup>(4)(5)</sup>		X		X
Restaurants	X						X	X	X
Hillside Development			X	X		X	X	X	X
Parking Lots		X	p <sup>(1)</sup>	p <sup>(2)</sup>		p <sup>(1)</sup>	X	p <sup>(5)</sup>	X
Streets, Highways & Freeways		X	p <sup>(1)</sup>	p <sup>(1)</sup>	X <sup>(4)</sup>	X	X	p <sup>(5)</sup>	X

X = anticipated    P = potential  
 (1) A potential pollutant if landscaping exists on-site.  
 (2) A potential pollutant if the project includes uncovered parking areas.  
 (3) A potential pollutant if land use involves food or animal waste products.  
 (4) Including petroleum hydrocarbons.  
 (5) Including solvents.  
 Source: CASQA New Development BMP Handbook, 2003, Errata 09-04.

## Step 2. Determine Requirements

Use Figure 3-1 to determine stormwater quality requirements for your project. Requirements depend on the size, type, and/or impervious area of your project (see Table 3-2 and Table 3-3). A few noteworthy aspects within this figure are called to the user's attention:

- All projects, regardless of type, size, or location, require implementation of the minimum prescribed source control measures. Refer to Step 4, Select Source Control Measures, and Chapter 4, **Source Control Measures**, for more information.
- An HMP Assessment based upon project size and location dictates the applicability of hydromodification control standards. The intent behind implementation of hydromodification control measures is to mitigate the impact of changes in runoff duration, rate and the discharge of bed sediment supply, based upon the Sacramento Stormwater Quality Partnership Hydromodification Management Plan (July 29, 2011; Revised February 14, 2013 and September 2017 Refer to Step 5, Select Hydromodification Control Measures, and Chapter 5, **Hydromodification Management, Low Impact Development, and Treatment Control Measures**, for more information. Refer also to: <http://www.beriverfriendly.net/Newdevelopment/>
- Implementation of low impact development (LID) measures is required of all projects above the impervious surface threshold applicable based upon land use (see Table 3-2 and Table 3-3). The intent behind implementation of LID is to reduce the increase in runoff volume created by the post project condition by about 50%, in other words, reduce the difference between pre-development and post-development volumes by 50%. Refer to Step 6, Select Low Impact Development Measures, and Chapter 5, **Hydromodification Management, Low Impact Development, and Treatment Control Measures**, for more information.
- Implementation of Treatment Control Measures is required of all projects above the impervious surface threshold applicable based upon land use (see Table 3-2 and Table 3-3). The intent behind implementation of treatment control measures or treatment control best management practices (TCBMPs) is to mitigate increased pollutant loading associated with the post project condition to the “maximum extent practicable.” Refer to Step 7, Select Treatment Control Measures, and Chapter 5, **Hydromodification Management, Low Impact Development, and Treatment Control Measures**, for more information.

Use Table 3-2 and Table 3-3 to determine the minimum “required” and “acceptable option” control measures necessary for your site to comply with Figure 3-1.

Table 3-2 Required Stormwater Quality Control Measures for Priority Projects

Priority Project Categories <sup>(1)</sup>	Required Stormwater Quality Control Measures				
	Source Control <sup>(2)</sup>	Hydromodification Control <sup>(3)</sup>	Low Impact Development Control	Treatment Control	Full Capture Trash Control <sup>(7)</sup>
Single Family Residential Impervious area $\geq$ 1 acre	X		X		X For projects with at least 10 du/acre <sup>(8)</sup>
Single Family Residential Gross Area $\geq$ 20 acres	X	X	X	X	
Multi-family Residential Impervious Area < 1 acre	X				
Multi-family Residential Impervious Area $\geq$ 1 acre	X	X	X	X	
Commercial/ Industrial Development <sup>(6)</sup> Impervious area < 1 acre	X				X For industrial projects where primary activities involve product manufacture, storage, or distribution. For commercial projects where primary activities involve sale or transfer of goods or services to consumers
Commercial/ Industrial Development <sup>(6)</sup> Impervious area $\geq$ 1 acre	X	X	X	X	
Automotive Repair Shops <sup>(6)</sup> Impervious area < 1 acre	X				
Automotive Repair Shops <sup>(6)</sup> Impervious area $\geq$ 1 acre	X	X	X	X	
Retail Gasoline Outlet <sup>(6)</sup> Impervious area < 1 acre	X				
Retail Gasoline Outlet <sup>(6)</sup> Impervious area $\geq$ 1 acre	X	X	X	X	
Restaurants Impervious area < 1 acre	X				
Restaurants Impervious area $\geq$ 1 acre	X	X	X	X	
Hillside Development Slope $\geq$ 25%	X	X	X	X	
Parking Lots <sup>(4)(6)</sup> Impervious area < 5,000 square feet or 25 parking spaces	X				
Parking Lots <sup>(4)(6)</sup> Impervious area $\geq$ 5,000 square feet or 25 parking spaces	X	X	X	X	
Streets & Roads <sup>(5)(6)</sup> Impervious area < 5 acres	X				
Streets & Roads <sup>(5)(6)</sup> Impervious area $\geq$ 5 acres	X	X	X	X	

- (1) Refer to Table 1-2 for more information on how each project category is generally defined and check with the local zoning code for the specific definition in a given jurisdiction.
- (2) Storm drain markings required for all projects. Other source controls required for all projects with applicable site activities. Choice of source control for hillside development depends on type of land use (commercial, residential, etc.).
- (3) If applicable, refer to Chapter 5, Hydromodification Management, Low Impact Development, and Treatment Control Measures, and Figure 5-2 of this Manual for the Hydromodification Management Applicability Map.
- (4) Only applies to stand-alone parking lots exposed to rainfall. Parking lots associated with buildings/facilities need to meet requirements of associated land use (commercial, industrial, etc.)
- (5) Municipal or private road projects and expansions that are not a part of new residential, commercial or industrial developments.
- (6) Threshold applies to municipal and private projects.
- (7) Refer to Appendix H for further information related to full capture trash control.
- (8) Dueling units per acre- du/acre

Table 3-3 Stormwater Quality Control Measure Selection Matrix

Priority Project Category <sup>(a)</sup>	Residential			Commercial/Industrial					Hillside Developments ≥ 25% slope	Parking lots <sup>(b)</sup> ≥ 5,000 sf or 25 spaces	Streets/Roads <sup>(c)</sup> Impervious area ≥ 5 ac
	Single Family Residential Impervious area ≥ 1 ac	Single Family Residential Gross area ≥ 20 ac	Multi-family Residential Impervious area ≥ 1 ac	Commercial Impervious area ≥ 1 ac	Auto Repair Shops Impervious area ≥ 1 ac	Retail Gasoline Outlets Impervious area ≥ 1 ac	Restaurants Impervious area ≥ 1 ac	Industrial Impervious area ≥ 1 ac			
<b>Source Control <sup>(d)</sup></b>	✓	✓	✓	✓	✓	✓	✓	✓	✓	✓	✓
Efficient Irrigation	✓	✓	✓	✓	✓	✓	✓	✓	✓	✓	✓
Fueling Areas	NA	NA	NA	✓	✓	✓	✓	✓	✓	NA	NA
Landscaping	✓	✓	✓	✓	✓	✓	✓	✓	✓	✓	✓
Loading Areas	NA	NA	NA	✓	✓	✓	✓	✓	✓	NA	NA
Outdoor Storage Areas	NA	NA	NA	✓	✓	✓	✓	✓	✓	NA	NA
Outdoor Work Areas	NA	NA	NA	✓	✓	✓	✓	✓	✓	NA	NA
Storm Drain Markings and Signs	✓	✓	✓	✓	✓	✓	✓	✓	✓	✓	✓
Vehicle/Equipment Wash Areas	NA	NA	✓	✓	✓	✓	✓	✓	✓	NA	NA
Waste Management Areas	NA	NA	✓	✓	✓	✓	✓	✓	✓	✓	NA
<b>Hydromodification Control, LID, and Treatment Control <sup>(e)(f)</sup></b>	(LID Only)	✓	✓	✓	✓	✓	✓	✓	✓	✓	✓
Alternative Driveways	•	•	•	NA	NA	NA	NA	NA	•	NA	NA
Capture and Re-Use	•	•	•	•	•	•	•	•	•	NA	NA
Compost-Amended Soil	•	•	•	•	NA	NA	•	•	NA	•	NA
Constructed Wetland Basin	•	•	•	•	NA	NA	•	•	NA	•	•
Disconnected Pavement	•	•	•	•	•	•	•	•	•	•	•
Disconnected Roof Drains	•	•	•	•	•	•	•	•	•	NA	NA
Green Roof	NA	NA	NA	•	•	•	•	•	•	NA	NA
Infiltration Basin	•	•	•	•	NA	NA	•	NA	NA	•	•
Infiltration Trench	•	•	•	•	NA	NA	•	NA	NA	•	•



Table 3-3, continued

Priority Project Category <sup>(a)</sup>	• Acceptable Option			“NA” Not applicable or allowed					Hillside Developments ≥ 25% slope	Parking lots <sup>(b)</sup> ≥ 5,000 sf or 25 spaces	Streets/Roads <sup>(c)</sup> Impervious area ≥ 5 ac
	Residential	Commercial/Industrial	Commercial/Industrial	Commercial/Industrial	Commercial/Industrial	Commercial/Industrial	Commercial/Industrial				
Control Measure	Single Family Residential Impervious area ≥ 1 ac	Single Family Residential Gross area ≥ 20 ac	Multi-family Residential Impervious area ≥ 1 ac	Commercial Impervious area ≥ 1 ac	Auto Repair Shops Impervious area ≥ 1 ac	Retail Gasoline Outlets Impervious area ≥ 1 ac	Restaurants Impervious area ≥ 1 ac	Industrial Impervious area ≥ 1 ac			
Interceptor Trees	•	•	•	•	•	•	•	•	•	•	•
Porous Pavement	(e)	(e)	(e)	•	NA	NA	•	NA	•	•	(e)
Sand Filter (Austin Sand Filter)	•	•	•	•	•	•	•	•	•	•	•
Bioretention Planter (Flow-Through)	•	•	•	•	•	•	•	•	•	•	•
Bioretention Planter (Infiltration)	•	•	•	•	NA	NA	•	NA	•	•	•
Underground Storage (Tanks, Vaults, etc.)	•	•	•	•	•	•	•	•	•	•	•
Vegetated Filter Strip	•	•	•	•	NA	NA	•	NA	•	•	•
Vegetated Swale	•	•	•	•	•	•	•	•	•	•	•
Water Quality Detention Basin	•	•	•	•	•	•	•	•	•	•	•
Proprietary Devices <sup>(g)</sup>	•	•	•	•	•	•	•	•	•	•	•
<b>Full Capture Trash Control<sup>(h)</sup></b>	✓	✓	✓	✓	✓	✓	✓	✓		✓	✓

(a) Refer to Table 1-2 for more information on how each priority project category is generally defined and check with the local zoning code for the specific definition in a given jurisdiction.

(b) Only applies to stand-alone parking lots exposed to rainfall. Parking lots associated with buildings/facilities need to meet requirements of associated land use (commercial, industrial, etc.)

(c) Municipal road projects and expansions that are not a part of new residential, commercial or industrial developments.

(d) Storm drain markings required for all projects. Other source controls required for all projects with applicable site activities. Choice of source control for hillside development depends on type of land use (commercial, residential, etc.)

(e) Consult local permitting agency to determine acceptability for use in public right-of-way.

(f) Alternative treatment controls may be proposed; subject to review and approval of local permitting agency. The need for treatment may be reduced through LID measures; see Appendix D. If the project drains to an adequately sized/designed regional treatment facility (e.g., detention basin), additional on-site treatment controls may not be needed.

(g) See discussion in Chapter 5 of this manual and [www.beriverfriendly.net](http://www.beriverfriendly.net) for list of acceptable devices.

(h) Refer to Appendix H for further information related to full capture trash control.

Figure 3-1 Identifying Stormwater Quality Requirements for New Development and Redevelopment Projects

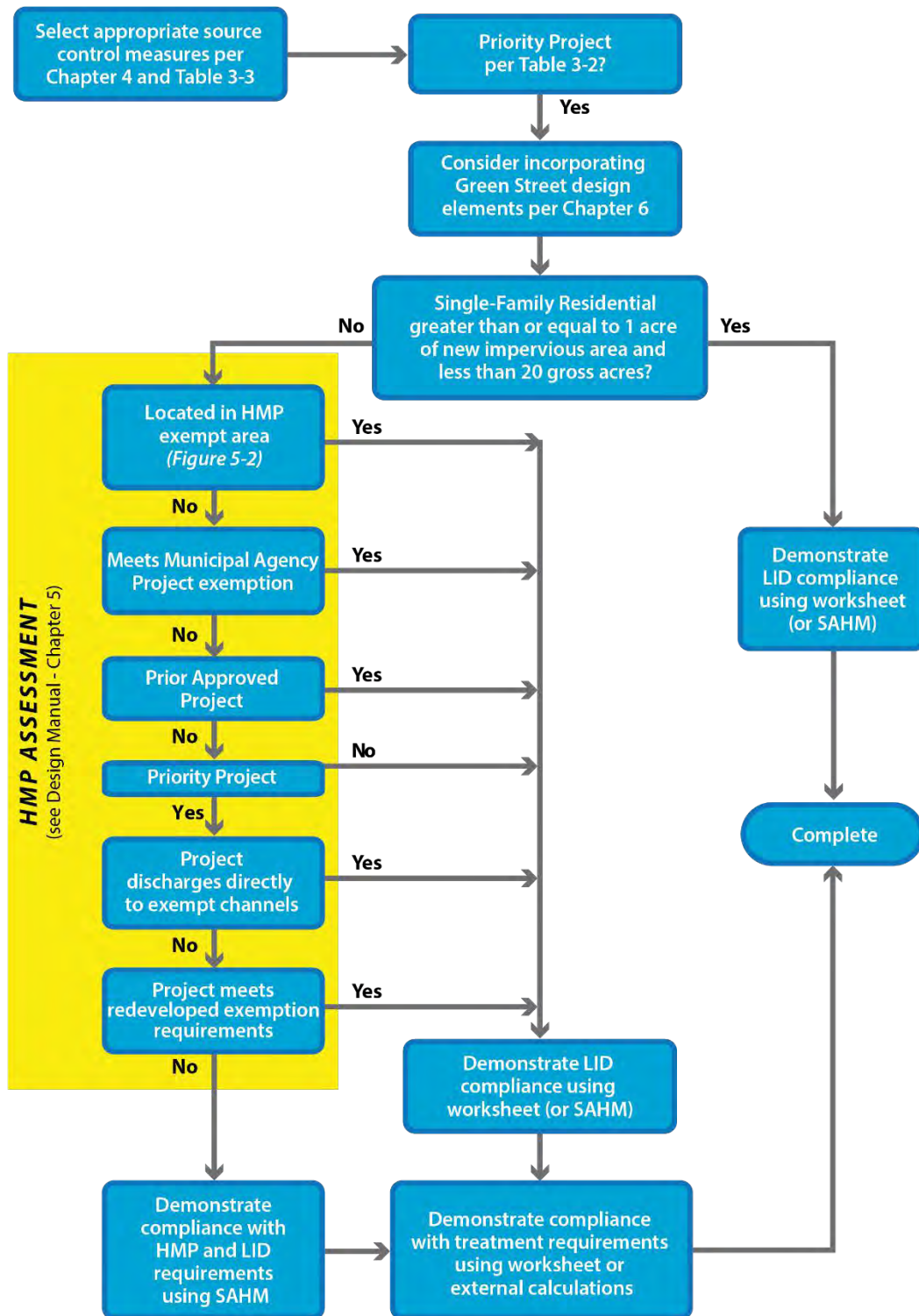

[Click here to link to Figure 5-2, Applicability Map.](#)

## Step 3. Evaluate Best Approach to Protect Stormwater Quality

Evaluate the best approach to protecting stormwater quality considering the site conditions, required controls, and the principles outlined in Chapter 2. In particular:

- Identify opportunities and constraints given the site conditions
- Preserve valuable site features where possible (and where required) and work with the topography
- Seek to integrate LID measures throughout the site design, such as incorporating them into landscaping and reducing runoff volume close to its source. Some projects are required to achieve a minimum number of points in order to meet LID performance standards (see Step 6, Select Low Impact Development Measures). LID measures provide the additional benefit of:
  - Providing water quality treatment
  - Mitigating hydromodification (flow duration) impacts
- Look for other cost-effective, aesthetically pleasing ways to treat runoff and manage the effects of hydromodification (if either is needed but cannot be achieved solely through implementation of acceptable LID measures.)

Identify and consider receiving water limitations based upon established “Total Maximum Daily Load” (TMDL) allocations, if any. In TMDL watersheds where urbanizing development has been determined to be a contributing source of impairment, increased emphasis should be applied to source control measures. Additional treatment standards and engineering analysis (beyond that described in this manual) for targeted constituents may be applied based upon the discretion of the individual jurisdiction or an approved waste load allocation (WLA). A current list of adopted TMDLs and other water quality impairments within California can be found at:

[http://www.waterboards.ca.gov/water\\_issues/programs/tmdl/integrated2010.shtml](http://www.waterboards.ca.gov/water_issues/programs/tmdl/integrated2010.shtml)

## Step 4. Select Source Control Measures (Chapter 4)

Based on Step 3, Evaluate Best Approach to Protect Stormwater Quality; Chapter 4, **Source Control Measures**; and Table 3-2 and Table 3-3, select appropriate source control measures. Source controls are intended to keep pollutants from mixing with runoff and traveling off the site. All projects require permanent “no dumping-drains to creek/river” markings to be applied to storm drain inlets. In addition, source control measures are required for the following areas where there is the potential for pollutants to be exposed to stormwater runoff:

- Fueling areas
- Loading areas
- Outdoor material storage areas
- Outdoor work areas (e.g., processing, manufacturing)
- Vehicle and equipment wash areas

---

*Source control measures  
keep pollutants  
from mixing with runoff and  
traveling off the site*

---

- Waste management areas (garbage, recycling, restaurant food waste)
- Landscaped areas
- Irrigated areas

## Step 5. Select Hydromodification Control Measures (Chapter 5)

Determine if hydromodification management control measures are required. If so, based on Step 3, Chapter 5, and, Table 3-2 and Table 3-3, select appropriate hydromodification control measures. When urbanization takes place, peak flow can increase, and runoff duration can be extended, causing artificial acceleration of natural erosion and sedimentation processes within the receiving streams. Hydromodification control measures are intended to mitigate this effect through attenuation, infiltration, and dispersion of additional runoff created by impervious surfaces and earthwork compaction. The extent of the measures chosen must satisfy the flow duration standards specified within the Sacramento Stormwater Quality Partnership Hydromodification Management Plan (July 29, 2011; Revised July 2018) and requires the use of continuous simulation modeling to demonstrate project compliance. The Sacramento Stormwater Quality Partnership has developed and made available a tool (Sacramento Area Hydrology Model, or SAHM) specifically for this purpose. SAHM and the SAHM User's Manual is available at <http://www.beriverfriendly.net/Newdevelopment/>. Refer to Chapter 5 for a more detailed explanation of compliance with flow duration standards using SAHM.

## Step 6. Select Low Impact Development Measures (Chapter 5)

Include LID measures in your project design if any of the following apply:

- Your project meets or exceeds the impervious acreage threshold (based upon project type), as specified in Figure 3-1.
- The project requires treatment controls (see Step 7, Select Treatment Control Measures) and you want to reduce the needed size (and associated cost) of required treatment.
- You conclude it is cost effective to incorporate LID measures and you would like to provide the environmental benefit of doing so.
- They are required by the local permitting agency for the particular project.

---

*Use of low impact development measures can decrease the size of required downstream water quality controls*

---

As described in Chapter 2, **Integrated Approach to Stormwater Management**, LID measures are intended to mimic natural hydrologic functions and reduce the amount of runoff traveling off the site. This is achieved by minimizing impervious surfaces, disconnecting impervious surfaces from the storm drain system, and promoting infiltration where possible. Even sites with clay soils can benefit from application of LID measures. Several different types of LID measures are:

- Alternative driveways
- Capture and re-use
- Compost-amended soil
- Disconnected pavement

- Disconnected roof drains
- Green roof
- Interceptor trees
- Porous pavement

Refer to Table 3-3 to identify which types of measures are acceptable for your project and then use the worksheets in Appendix D to calculate the LID points you can achieve by incorporating one or more of these measures into your project. A total of 100 points are required for qualifying projects. Then use the worksheets to calculate any remaining water quality volume or flow that needs to be treated and proceed to Step 7, Select Treatment Control Measures, to select the treatment control facilities. If the entire water quality volume (WQV) can be treated effectively using low Impact development, no additional treatment control measures will be required, and you can advance to Step 8, Design Facilities (Preliminary).

## Step 7. Select Treatment Control Measures (Chapter 5)

Treatment control measures are intended to filter and settle pollutants out of runoff before it travels off the site. If treatment controls are required per Figure 3-1 (and still needed after the calculation of LID credits in Step 6, Select Low Impact Development Measures), select the appropriate treatment control measures. To do so, use your analysis in Step 3, Evaluate Best Approach to Protect Stormwater Quality; the details in Table 3-3 regarding whether a given control measure is acceptable for the project category; and the information in Chapter 5. Chapter 5 also includes fact sheets for a variety of treatment control measures:

- Constructed wetland basin
- Water quality detention basin  
(three types: wet, dry, combination)
- Infiltration basin
- Infiltration trench
- Sand filter
- Bioretention (a.k.a. “Stormwater planter” - two types: flow-through and infiltration)
- Vegetated filter strip
- Vegetated swale

---

*Treatment control measures are intended to filter and settle pollutants out of runoff before it travels off the site*

---

Proprietary devices, such as stormwater media cartridge systems, may also be allowed for the project. Selected devices must meet the local permitting agency’s approval. Refer to

[www.beriverfriendly.net](http://www.beriverfriendly.net) for information about which devices are currently accepted. Additional information about the agencies’ approval programs is provided in Chapter 5.

When you have made a preliminary selection of the treatment control measures for your site, refer to the fact sheets in Chapter 5 and the sizing methodology in Appendix E to ensure that there is adequate space on your site for the measure(s). This may require an iterative process working with various types of control measures until the right combination is identified for the project. Depending

on your preliminary calculations, you may also want to reconsider additional LID measures to reduce the needed size of treatment facilities (revisit Step 6, Select Low Impact Development Measures).

At this stage in the process, the design engineer should also give consideration to the available options for sizing LID and hydromodification control measures using computer software or spreadsheet analysis. In all applicable projects, sizing of BMPs for hydromodification control must be performed using the Sacramento Area Hydrology Model Software (SAHM). However, in justifying the required LID points (a function of managed area percentage and stormwater volume reduction), the designer is given the option to use either SAHM, or a basic spreadsheet prepared by the Permittees. The spreadsheet is intended as a relatively simple but conservative tool. As indicated previously, its use is optional. However, this tool is recommended as most suitable for the following circumstances:

1. Projects not subject to hydromodification management standards (as those projects would already be producing a SAHM model capable of accurately evaluating LID compliance)
2. Projects using a comparatively limited (i.e., 1 or 2) BMPs to meet minimum LID point standards. Projects that employ extensive (3 or more) BMPs in series can typically produce significant volume reduction that the spreadsheet (due its simplistic nature) cannot accurately value, and consequently will produce results that are overly conservative. In such instances, a physically based continuous simulation such as SAHM is recommended. Acceptance of other modeling software is at the discretion of the individual permitting agency.

### Step 8. Design Facilities (Preliminary)

At this point in the process you have selected the suite of control measures for your project, assessed the need for hydromodification compliance and sizing of requisite control measures, calculated the LID credits (as required) and determined preliminary sizing for any and all additional treatment facilities. Now it is time to compile and submit the information to the applicable permitting agency with the planning application. Check with the agency for their submittal requirements and be sure to consult with their stormwater quality staff before proceeding to Step 9, Design Facilities (Final). Consider scheduling a pre-application meeting just for this purpose or include stormwater quality as an agenda item on a pre-scheduled pre-application meeting. The stormwater quality staff will review the proposal, check that the standards would be satisfied by the proposal, and provide suggestions; however, final design and sizing of the facilities will not be checked by the permitting agency until later in the process.

### Step 9. Design Facilities (Final)

Using feedback from permitting agency staff obtained in Step 8; complete the final design of the stormwater quality facilities for submittal with construction or improvement plans to the local permitting agency. Appendix A outlines the minimum submittal requirements for this post-construction stormwater quality plan submittal. The submittal must provide sufficient design details,

calculations and other information to demonstrate the adequacy of the proposed stormwater quality design for the project. Record all this design information on the design data summary sheet found at the end of each fact sheet in Chapter 5.

Appendix A also presents an example of a typical post-construction plan submittal required by member agencies of the Sacramento Stormwater Quality Partnership. Check the web site for additional agency examples as they become available: [www.beriverfriendly.net](http://www.beriverfriendly.net).

Some permitting agencies may require a certificate of control measure compliance or similar certification before the project is deemed complete. Since every agency does this somewhat differently, it is critical to check with the applicable agency.

## Step 10. Establish Long Term Maintenance Requirements

For projects using any structural hydromodification controls, or treatment control measures, verification of long-term maintenance provisions is required. This is mandated by the agencies' municipal stormwater permits. The local permitting agencies in the Sacramento area will ensure a maintenance plan is in place through the execution of a maintenance agreement, covenant or permit with the property owner.

Each fact sheet in Chapter 5, **Hydromodification Management, Low Impact Development, and Treatment Control Measures**, for a control measure that requires a maintenance plan includes a table listing inspection and maintenance recommendations. This table (as amended by the project designer/property owner, if applicable) is meant to be incorporated into the maintenance agreement for the project.

---

*Verification of long-term maintenance provisions is required for projects using stormwater quality treatment control measures such as vegetated swales and bioretention planters. See Appendix B for a complete list.*

---

Typically, maintenance agreements and covenants are recorded with the deed for the property and follow property ownership. The agreements generally include provisions for the permitting agency to recover costs for maintenance in the event that the property owner fails to fulfill their obligations. They also require reconstruction or replacement of the feature when it fails to function properly. For informational purposes, Appendix B presents projected lifespan information for the various control measures.

Check with the local permitting agency about the maintenance submittal requirements and timing for execution of the agreement. See Appendix B for additional information and sample maintenance agreements.

## Step 11. Construct

During the construction phase, follow the construction guidelines for the stormwater quality control measures described in the fact sheets found later in this manual. It is particularly important to protect the facilities from receiving sediment loads during the construction process. To protect

## Chapter 3: Steps to Managing Stormwater Quality

facilities from adjacent construction activities, educate the construction superintendent and use erosion and sediment control techniques, such as erosion control blankets and straw wattles/fiber rolls. For construction erosion and sedimentation control standards and details, reference the local permitting agency's standard specifications and/or guidance manuals (see Appendix F for contact information). Because the state of this practice is evolving rapidly, be sure to check with the permitting agency to verify that you have the most current edition.

Projects will not be accepted until all stormwater quality measures are installed properly. Please refer to Appendix G for an inspection checklist that can be used during construction.



# Chapter 4. Source Control Measures

---

## Source Control Principles

Source control measures are designed to prevent pollutants from contacting site runoff, leaving the site and entering the municipal storm drain system or local waterways. Development and redevelopment projects are required to employ source control measures appropriate to the planned site operations/activities (see Table 3-3 in Chapter 3, **Steps to Managing Stormwater Quality**).

This design manual addresses source control measures that can be implemented as part of the project design process. As noted in Chapter 1, it does not include ongoing behavioral-based, operational source control measures such as good housekeeping practices, spill control procedures and employee training. For information about operational best management practices to reduce stormwater pollution, consult the local permitting agencies, visit [www.beriverfriendly.net](http://www.beriverfriendly.net) (select “Industrial/Commercial Element”), and/or look for that information in the *California Stormwater Best Management Practice Handbook* ([www.cabmphandbooks.com](http://www.cabmphandbooks.com)).

Source control measures apply to both stormwater and prohibited non-stormwater discharges. Non-stormwater discharges include anything not composed entirely of stormwater (such as cooling water, process wastewater, etc.). Stormwater that is mixed or commingled with other non-stormwater flows is considered non-stormwater. Local, state or federal permits may be required for discharges of stormwater and non-stormwater to the storm drain system or a water body. To verify this, check with your local permitting agency.

Exceptions to non-stormwater discharge prohibition include the following (provided that any such discharge does not cause or contribute to the violation of any receiving water limitations):

- Water line flushing
- Landscape irrigation
- Diverted stream flows
- Rising ground waters
- Uncontaminated ground water infiltration
- Uncontaminated pumped ground water
- Discharges from potable water sources
- Foundation drains
- Air conditioning condensate
- Uncontaminated irrigation water
- Springs
- Water from crawl space pumps
- Footing drains
- Lawn watering
- Individual residential car washing
- Flows from riparian habitat and wetlands
- Dechlorinated swimming pool discharges

- Discharges or flows from emergency firefighting activities

## Selecting Source Control Measures for Your Project

Use Table 3-3 to determine which source control measures are required for your project.

Some of the source control measures described in this chapter suggest discharging potentially polluted site runoff to the sanitary sewer system. This requires prior approval of the local sanitation district and may require a permit. Discharges of certain types of flows to the sanitary sewer system may be cost prohibitive due to connection fees and flow charges. Appendix C provides permitting and contact information for the various sanitation district agencies in this area.

## Source Control Fact Sheets

This chapter includes fact sheets for all of the source control measures listed in Table 3-3. Each fact sheet describes the purpose of the control measure, applicability, design requirements, and any operation and maintenance issues that may affect its design.

## References

The following general references were used to develop this chapter and the fact sheets found at the end of this chapter:

- California Stormwater Quality Association, *California Storm Water Best Management Practice Handbook for New Development and Redevelopment*, January 2003 (Revised September 2004). <http://www.cabmphandbooks.com>
- City of Austin, Texas, *Earth-wise Guide to Irrigation*, <http://www.austintexas.gov/sites/default/files/files/Watershed/growgreen/irrigation.pdf>.
- City of Olympia, Washington, *Water Wise Irrigation*, <http://m.olympiawa.gov/city-utilities/drinking-water/conservation.aspx>.
- City of Portland, *City of Portland Stormwater Management Manual*, September 2004 (Revised 2008). <https://www.portlandoregon.gov/citycode/article/12548>
- City of Sacramento, Department of Utilities, *Frequently Asked Questions: Water Conservation Ordinance and Water Efficiency*, <https://www.cityofsacramento.org/Utilities/Conservation>
- City of Sunnyvale, *The City of Sunnyvale Stormwater Quality BMP Guidance Manual for New and Redevelopment Projects*, October 2003 (Revised December 2011). [http://qcode.us/codes/sunnyvale/?view=desktop&topic=12-12\\_60-12\\_60\\_040](http://qcode.us/codes/sunnyvale/?view=desktop&topic=12-12_60-12_60_040)
- Portland Water Bureau, *Irrigation Fact Sheet*, <http://www.portlandoregon.gov/water/article/268759>.
- River-Friendly Landscaping, *The Seven Principles of River-Friendly Landscaping (RFL)*, <http://www.msa.saccounty.net/sactostormwater/RFL/principles.asp>, accessed 6/12/13.

- Sacramento Stormwater Management Program, *BMPs for Industrial Stormwater Pollution Control*, 2001. <http://www.waterresources.saccounty.net/stormwater/documents/industrial-BMP-manual.pdf>
- Sacramento Stormwater Quality Partnership, *Guidance Manual for On-Site Stormwater Quality Control Measures*, January 2000.
- State of Washington, Department of Ecology, *Stormwater Management Manual for Western Washington*, Volume 1, February 2005 (Revised 2012). <http://www.ecy.wa.gov/programs/wq/stormwater/manual.html>
- University of Nevada, Reno, *Using Fertilizers Properly, A Tahoe Landscape BMP Fact Sheet for Lake Tahoe*, Fact Sheet 94-11.

THIS PAGE LEFT INTENTIONALLY BLANK

# Efficient Irrigation

---

## Purpose

This fact sheet provides details about efficient irrigation for the purpose of reducing water use and dry weather runoff from excess irrigation for residential and commercial projects. Improper irrigation generates runoff that transports bacteria, fertilizers and pesticides to local natural waterways. Some jurisdictions have specific water conservation ordinances that outline how customers can save water by adjusting their irrigation schedules to prevent overspray and runoff. Below are links to some of the jurisdiction's water conservation codes.

- City of Elk Grove: Chapter 14.10 Water Efficient Landscape Requirements  
<http://www.codepublishing.com/CA/ElkGrove/html/ElkGrove14/ElkGrove1410.html#14.10>
- City of Folsom: Municipal Code, Title 13 Water and Sewage – Chapter 13.26 Water Conservation  
[http://www.folsom.ca.us/depts/city\\_clerk/charter.asp](http://www.folsom.ca.us/depts/city_clerk/charter.asp)
- Citrus Heights: Municipal Code, Chapter 98 – Utilities, Article II. - Water, Division 3. – Use and Conservation  
<http://library.municode.com/index.aspx?clientId=13326>
- City of Sacramento: Water Efficient Landscape Requirements-Chapter 15.92: Landscaping Requirements for Water Conservation  
[http://www.qcode.us/codes/sacramento/?view=desktop&topic=15-15\\_92-15\\_92\\_010](http://www.qcode.us/codes/sacramento/?view=desktop&topic=15-15_92-15_92_010)
- City of Galt Water: Chapter 13.10: Water Conservation  
<http://www.codepublishing.com/CA/galt/>
- County of Sacramento and City of Rancho Cordova: Title 14 Agricultural Activities And Water Use And Conservation  
[http://qcode.us/codes/sacramentocounty/view.php?topic=14-14\\_10&frames=on](http://qcode.us/codes/sacramentocounty/view.php?topic=14-14_10&frames=on)

Some ordinances have strong enforcement measures including fines for repeat offenders. By following a few simple steps for efficient irrigation, residents can make a positive impact on local water quality.

## Applicability

Efficient irrigation should be implemented to the maximum extent practicable for all landscaped areas that require irrigation and in accordance with Model Water Efficient Landscape Ordinance AB 1881.

## Design Requirements

### General

Most irrigation systems can easily be designed or updated to offer maximum water use efficiency and prevent runoff. A well-designed irrigation system will deliver the appropriate amount of water needed, but will not generate excess runoff or overspray onto impervious surfaces. Automatic shutoff valves that turn off irrigation systems when there is a broken pipe or sprinkler head, or when it is raining, should be incorporated into the design. Timers should be installed to control the schedule of the irrigation. Landscapes should include drought tolerant vegetation where feasible, reducing the required frequency of watering.

Smart irrigation controllers can automatically adjust the rate and timing of irrigation based on soil and weather conditions. These systems often use historic weather data as well as site-specific data and include underground sensors that monitor soil moisture. Smart systems will not only automatically shut off when it is raining, but can also make automatic seasonal adjustments.

### Manual Irrigation

There are a variety of products available to make hand watering easy – soaker hoses, automatic shutoff hose nozzles, and portable sprinklers. When watering manually, allow water to soak into the ground by using slow spray patterns as opposed to a constant and direct watering stream; many commercially available portable sprinklers incorporate a rotor action to meet this need.

### Drip/Micro Spray Irrigation

Drip irrigation is the most effective way of getting water directly to plant roots. This is done by delivering small amounts of water to the ground over a longer period of time. This eliminates wasted water to misting, foliage blockage, and overspray, and also significantly reduces the potential for runoff. These systems work very well in areas with clay soils; which are more prone to irrigation runoff, or cobble/rocky soils, which can drain too quickly. There are several different types of drip irrigation systems that are available – bubblers, micro sprayers and drippers. Drip systems require a low pressure water system. This can be achieved by installing a pressure regulator to an existing in-ground system. These systems can clog over time from lime build up and suspended particles - installing filter systems can help alleviate this problem. Most systems come pre-packaged with user installation and operation instructions.

### Scheduling

- To reduce water loss from evaporation, water landscapes before 10 a.m. or after 6 p.m.
- Spring and Summer- irrigate no more than three times per week.
- Fall and Winter- keep systems turned off as much as possible and irrigate no more than once per week when necessary.
- Reduce the frequency of irrigation during and immediately after rain events. Automatic shut off devices can be used to automatically stop irrigation during a rain event.
- New landscaping may require more frequent irrigation for root establishment.

## Operation & Maintenance

- Check for broken sprinkler heads and leaks monthly. Leaks are easy identified by looking for wet spots, areas that are overgrown or weak water outputs.
- Cap, close (tighten small screw on top), or remove any unnecessary sprinklers.
- If a sprinkler head is blocked by foliage move the sprinkler head, install a riser, or eliminate the foliage.

THIS PAGE INTENTIONALLY LEFT BLANK



# Fueling Areas

---

## Purpose

This fact sheet specifies how to locate and design vehicle and equipment fueling areas so that pollutants do not enter the storm drainage system and receiving waters. Leaked engine fluids and spilled fuel inevitably accumulate on the pavement around fueling areas, and they contain toxic materials and heavy metals that are not easily removed by stormwater treatment devices. The design requirements on this fact sheet are intended to prevent spilled fuel and other potential pollutants (such as oil and grease, solvents, car battery acid, and coolant) from contacting stormwater runoff or entering the storm drainage system.



*Covered fueling area. Photo source unknown*

## Applicability

This fact sheet applies to design of fueling areas at new development or significant redevelopment of retail or commercial gasoline outlets, automobile maintenance/repair facilities, corporation yards, and any other facility incorporating a permanent fueling area. This fact sheet is intended for use during facility design and therefore does not address mobile fueling operations. It also does not include requirements for design of bulk fuel terminals (fuel farms). Contact the local permitting agency for requirements applicable to that type of industrial development.

## Design Requirements

To protect water quality, design vehicle or equipment fueling areas as explained in Table FA-1. Design requirements on this fact sheet are intended to supplement (not supersede) those in other codes (such as the Building, Fire, and Zoning Codes and the hazardous waste requirements in Title 22, California Code of Regulations, as applicable). Discuss any potential conflicts with the local permitting agency early in the planning process before proceeding with design.

## Fueling Areas



*Interceptor drains on the fueling pad perimeter at this retail gasoline outlet in Folsom catch spills and incidental contaminated wash water and direct it to an onsite 750-gal underground containment tank.*



*This retail gasoline outlet in Folsom has perimeter drains around both the concrete fueling pad and the concrete fuel transfer area. The drain carries spills and runoff to an onsite underground containment tank.*

## Operation and Maintenance

The design features required by this fact sheet need to be maintained and properly operated and may be subject to inspections by local fire and/or sanitary sewer agencies, depending on the configuration.

*Table FA-1. Design Requirements for Fueling Areas to Protect Water Quality*

Design Feature	Requirement
Paving	<ul style="list-style-type: none"> <li>▪ Use Portland cement concrete for the surface of the fuel dispensing area, which is defined as the entire area between adjacent fuel pumps and extending out at least 6.5 ft. beyond the outer edges of the perimeter pumps. Asphalt is not permitted.</li> <li>▪ Use Portland cement concrete for the surface of the fuel transfer area. Asphalt is not permitted.</li> <li>▪ Use asphalt sealant to protect any asphalt paved areas surrounding the concrete fueling and transfer areas.</li> </ul>
Cover	<ul style="list-style-type: none"> <li>▪ Cover the fueling area with a roof structure or canopy unless the fueling area will be used routinely for oversized equipment or vehicles (such as cranes) that cannot be accommodated under cover. In such cases, special drainage requirements will apply; check with local permitting agency.</li> <li>▪ Design the cover height per the building code (CBC 311.2.3.2 minimum cover height is currently 13'-6").</li> <li>▪ Extend the cover at least 5 feet beyond the fuel dispensing area.</li> </ul>

Design Feature	Requirement
Grading/ Drainage	<ul style="list-style-type: none"> <li>▪ Design drainage system so that runoff from the roof/canopy is directed to an on-site vegetated area prior to connection to the storm drain system.</li> <li>▪ If possible, design the fuel dispensing and transfer area pads with adequate slope to keep minor spills on the pad and encourage proper cleanup. Check this with the local permitting agency.</li> <li>▪ Do not place a storm drain inlet in or near the fuel dispensing area (discharge to the storm drain system is not allowed). Check with local permitting agency to determine if there are minimum spacing requirements between fueling area and nearest inlet.</li> <li>▪ Hydraulically isolate the fuel dispensing and transfer areas from the rest of the site to contain spills and incidental wash water, prevent run-on, and prevent stormwater runoff from carrying pollutants away. Use one of the following methods:               <ul style="list-style-type: none"> <li>▪ Berms: Design the pad as a spill containment pad with a sill or berm raised at least 4 inches (raised sills are not required at open gate trenches that connect to an approved drainage control system.)</li> <li>▪ Perimeter drains: Locate drains around the perimeter of the pad. Drain accumulated water in one of two ways, depending on local permitting agency requirements: 1) to an onsite containment system (for eventual pump-out and off-site disposal), or 2) to the sanitary sewer, if equipped with automatic shutoff valve (see next section of table).</li> </ul> </li> <li>▪ Ensure that all grading, grade breaks and berms comply with applicable ADA requirements for disabled access.</li> </ul>
Onsite Containment System	<ul style="list-style-type: none"> <li>▪ If the local permitting agency and fire district (in some cases two different agencies) allows the connection of inlets or interceptor drains in the fuel dispensing and/or transfer area(s) to an onsite containment tank, then size the tank according to applicable requirements.</li> </ul>
Connections to sanitary system	<ul style="list-style-type: none"> <li>▪ If the sanitary sewer connection permitting agency allows inlets or interceptor drains that drain the fuel dispensing and/or transfer area(s) to connect to the sanitary sewer, equip such inlets and drains with a shutoff valve <u>or</u> spill control manhole (see below) to keep fuel out of the sanitary sewer in the event of a spill. See appendix “C” for contact information for the local sanitary sewer connection agencies.</li> <li>▪ Spill control manhole option: Install manhole on the discharge line of the fueling pad (before the sanitary sewer line tie in); extend the tee section 18 inches below the outlet elevation and provide 60 cubic feet of dead storage volume (for oil, grease, and solids) below the outlet elevation.</li> </ul>
Signage	<ul style="list-style-type: none"> <li>▪ If not otherwise required, post signs that state, “Do not top off gas tanks” to prevent spills.</li> <li>▪ Post sign(s) explaining the operation of any shut-off valves for facility employees, if applicable.</li> </ul>
<p><i>These requirements are intended to supplement, not supersede, those found in other codes (e.g., building, plumbing, fire). If conflicts are identified, consult with the local development permitting agency and other agencies as needed (e.g., fire, sanitation district) for resolution.</i></p>	

THIS PAGE INTENTIONALLY LEFT BLANK

# Landscaping

---

## Purpose

Proper planning and design of landscaping is an easy way to positively impact local and regional water quality. Aside from the aesthetic value that is created, a well-designed landscape is an effective source control measure that can reduce runoff volume, peak flow rate, pollutant load, and water usage.

## Applicability

The source control options provided in this fact sheet must be considered within all new development and redevelopment projects, and incorporated to the maximum extent practicable.



*2500 River Plaza, City of Sacramento*

## Design Requirements

When designing landscape to reduce water quality impacts, the following design principles should be considered:

- Incorporate natural depressions, rain gardens and/or swales into the design to maximize natural water storage and infiltration opportunities. Refer to the Bioretention Planter and Vegetated Swale BMP Fact Sheets.
- Protect existing slopes and channels (additional guidance can be found in the City of Sacramento Manual for Grading and Erosion and Sediment Control<sup>1</sup>, from CASQA and/or other local agency publications).
  - Protect disturbed slopes and channel crossings as quickly as possible.
  - Use methods to slow runoff flow where appropriate to prevent erosion.
- Organic fertilizers should be used instead of synthetic fertilizer because they are less soluble in water and less likely to be transported to natural water ways by stormwater runoff. In some cases, use of organic wood mulch can eliminate the need to use any fertilizers.

---

<sup>1</sup> <http://www.sacstormwater.org/ConstructionandNewDevelopment/ConstructionandNewDevelopment.html>

## Landscaping

The Sacramento Stormwater Quality Partnership has adopted several principles of “river-friendly” landscaping. These include the following:

- Landscape locally – take into account the existing site characteristics.
- Landscape for less to the landfill – compost onsite plant debris and select plants that require minimal pruning.
- Nurture the soil – amend the soil with compost before planting and mulch regularly after planting.
- Conserve Water – minimize the use of lawns and select drought resistant Californian & native plant varieties.
- Conserve Energy – plant trees to shade homes and reduce unnecessary outdoor lighting.
- Protect water & air quality – Minimize the use of pesticides.
- Create and protect wildlife habitat – preserve existing vegetation and select native plants.

## Operation and Maintenance

### General

- Reduce the potential for dry weather runoff by installing efficient irrigation systems (see Efficient Irrigation BMP Fact Sheet).
- Over watering after fertilizer application can leach nitrogen into the surrounding water ways.
- Apply fertilizer only in the spring and fall (if needed).
- Sweep up all fertilizer, soil and plant clippings off of paved surfaces to prevent contact with stormwater runoff.
- Limit soil compaction when constructing landscaped areas. Compaction will reduce the amount of runoff that can be stored and infiltrated.

### Fertilizer Application

If fertilizers are improperly applied, the nutrients they contain will bypass the plant and end up polluting stormwater runoff. These nutrients can cause detrimental algae blooms in the receiving creek. It is very important to follow the instructions included with the fertilizer for application. There are several different fertilized application methods:

- Surface Application – a fertilizer spreader should be used to apply evenly over an area.
- Soil Incorporation – the best method for applying low soluble nutrients like potassium and phosphorus is to place it into a hole or a trench dug around an individual plant.
- Foliage Spraying - spraying a fertilizer solution onto the leaves of plants is an efficient way to apply micro nutrients such as zinc and iron. It is not recommended for applying potassium or phosphorus.

Table L-1 Fertilizer Comparison

Fertilizer Type*:	Nutrient Origin	Advantages	Disadvantages
Organic	Remains or byproduct of ounce-living organisms, such as compost, bone meal, sewage sludge and fish emulsion	Improves soil health, less leachable, contains multiple nutrients	High cost per unit of nutrient
Inorganic (synthetic)	Synthesized from non-living materials. They are typically salts like ammonium sulfate, potassium chloride and potassium phosphate.	Low cost, consistent nutrient levels, readily available to plants, easy to handle	Potential loss by leaching, more easily over-applied

\*Use of mulch can reduce or eliminate the need to apply fertilizer

## References Used to Develop This Fact Sheet

- California Stormwater Quality Association, *California Storm Water Best Management Practice Handbook for New Development and Redevelopment*, January 2003 (revised September 2004). [www.cabmphandbooks.com](http://www.cabmphandbooks.com)
- River-Friendly Landscaping, *The Seven Principles of River-Friendly Landscaping (RFL)*, <http://www.msa.saccounty.net/sactostormwater/RFL/principles.asp>, accessed 6/12/13.
- University of Nevada, Reno, *Using Fertilizers Properly, A Tahoe Landscape BMP Fact Sheet for Lake Tahoe*, Fact Sheet 94-11.

THIS PAGE INTENTIONALLY LEFT BLANK



# Loading Areas

---

## Purpose

This fact sheet specifies how to design loading/unloading areas to minimize the chance of spills and leaks and to keep any spilled/leaked materials out of the storm drain system and receiving waters. Potential pollutants addressed depend on the operations and materials being handled, but may include toxic compounds, oil and grease, nutrients, suspended solids, fluids leaked from delivery vehicles, and/or other contaminants. Leaked fluids from delivery vehicles can also accumulate in the loading area.



*Delivery loading/unloading area.  
Photo source unknown*

## Applicability

Refer to Table 3-3 regarding the project land use types that need to comply with this fact sheet. The design requirements provided in this fact sheet are primarily intended for new development. If applied to significant redevelopment, the requirements would only apply in the case of complete redesign of the loading area.

## Design Requirements

To protect water quality, design loading/unloading areas as explained in Table LA-1. These requirements are not intended to supersede other codes or other loading dock design or access requirements established by individual companies; discuss any potential conflicts with the local permitting agency early in the planning process before proceeding with design. It is recognized that some land uses (e.g., food-handling, chemical distribution, hazardous materials) have a greater potential to pollute stormwater if spills were to occur than other land uses and the level of control needed therefore varies. However, most times agency planners/reviewers will not know the use of the building at the time of plan approval. Further, warehouses and other buildings often have tenant turnover and use/materials handled will change over time. Therefore, a single set of design requirements is provided in order to address all anticipated land use types.

## Operation and Maintenance

The design features required by this fact sheet need to be maintained and properly operated. This includes proper handling and disposal of any materials which may accumulate in the spill

## Loading Areas

containment vault. In addition, features may be subject to inspections by local fire and/or sanitary sewer agencies, depending on the configuration.

*Table LA-1. Design Requirements for Loading Areas to Protect Water Quality*

Design Feature	Requirement
Paving	<ul style="list-style-type: none"> <li>▪ Pave the loading area with an impervious paving material that is compatible with materials that will be loaded/unloaded. For example, use Portland Cement Concrete if gasoline or other materials that react with asphalt will be loaded/unloaded.</li> </ul>
Cover	<ul style="list-style-type: none"> <li>▪ Several options are presented for covering the active loading area, to minimize the exposure of pollutants to rainfall and runoff; check with the local permitting agency on which of the options will be allowed for the project:</li> <li>▪ Option 1. If feasible, design the facility so loading/unloading occurs inside an indoor loading bay. This is the best option from the perspective of protecting stormwater quality. If this is not feasible, consider the next option.</li> <li>▪ Option 2. For buildings with less than 10 bays, provide a roof overhang that extends at least 10 feet beyond the loading dock (or the building face, if there isn't a loading dock). If the building includes 10 or more bays or a cover is deemed otherwise not feasible, consider the next option and proceed to "Grading/Drainage" element of this table.</li> <li>▪ Option 3. Use of a door skirt that fits snugly to both the trailer end and the building door during material transfers maybe allowed on a case-by-case basis. Check with the permitting agency for verification.</li> </ul>
Grading/Drainage	<ul style="list-style-type: none"> <li>▪ Direct runoff from roof downspouts away from the loading/unloading areas.</li> <li>▪ Design outdoor loading areas so that the first 6 ft. of pavement, as measured from the dock face (or from the building if there is no elevated loading dock) is hydraulically isolated to prevent runoff/runoff. This can be accomplished with berms, grading, or interceptor drains. See Figure LA-1 for suggested configuration using interceptor drains; check acceptability of this method with local permitting agency.</li> <li>▪ Option 1: Drain the hydraulically isolated area to a pretreatment device (e.g., oil/water separator) then to the sanitary sewer (discharge to the storm drain system is not allowed); equip the system with an emergency spill shut-off/diversion valve as described below. Verify that this is acceptable to the local permitting agency; the agency may require a cover on the entire area draining to the sanitary sewer.</li> <li>▪ Option 2: For projects that can't connect to the sanitary sewer, loading areas can be hydraulically isolated from the rest of the site drainage system using any approved treatment BMP. The selected treatment BMP shall be designed to treat the WQF or WQV from the loading dock area, plus 312 gallons. The selected treatment BMP must be solely dedicated to treating runoff from the loading area. A maintenance agreement will be required for the selected treatment BMP.</li> <li>▪ Refer to Appendix C for sanitary sewer connection and contact information.</li> </ul>

Design Feature	Requirement
Spill Control Diversion Valve and Containment Tank	<ul style="list-style-type: none"> <li>▪ Equip the drainage system with an emergency spill shut-off/diversion valve.</li> <li>▪ The bypass on the shut-off valve should flow to an adequately-sized* spill containment vault located a safe distance away from structures due to potential for explosive/fire reaction (see Figure LA-1). This is subject to approval of local permitting agency and fire department/district (could be two different agencies).</li> </ul> <p><i>*The size of the spill containment vault should be equal to 125% of the volume of the largest container handled at the facility. If this is not known, assume that 250 gal is typically largest size handled at the loading areas. Containment vault would be 312 gal in this case.</i></p>
Indoor Loading Areas – no obstruction zones	<ul style="list-style-type: none"> <li>▪ If loading is designed to occur indoors (beyond a bay door), provide a 10-ft. no obstruction zone within the building to allow the truck to extend inside and to provide a staging area. Clearly identify the no obstruction zone on the building plan. Clearly mark the no obstruction zone at an interior transfer area using bright or fluorescent floor paint.</li> </ul>
Signage for Spill Control Features	<ul style="list-style-type: none"> <li>▪ Provide signage to identify the location and simple use instructions of any spill control/response design features (such as shutoff valves or spill response kits).</li> </ul>
<p><i>These requirements are intended to supplement, not supersede, those found in other codes (e.g., building, plumbing, fire). If conflicts are identified, consult with the local development permitting agency and other agencies as needed (e.g., fire, sanitation district) for resolution.</i></p>	

# Loading Areas

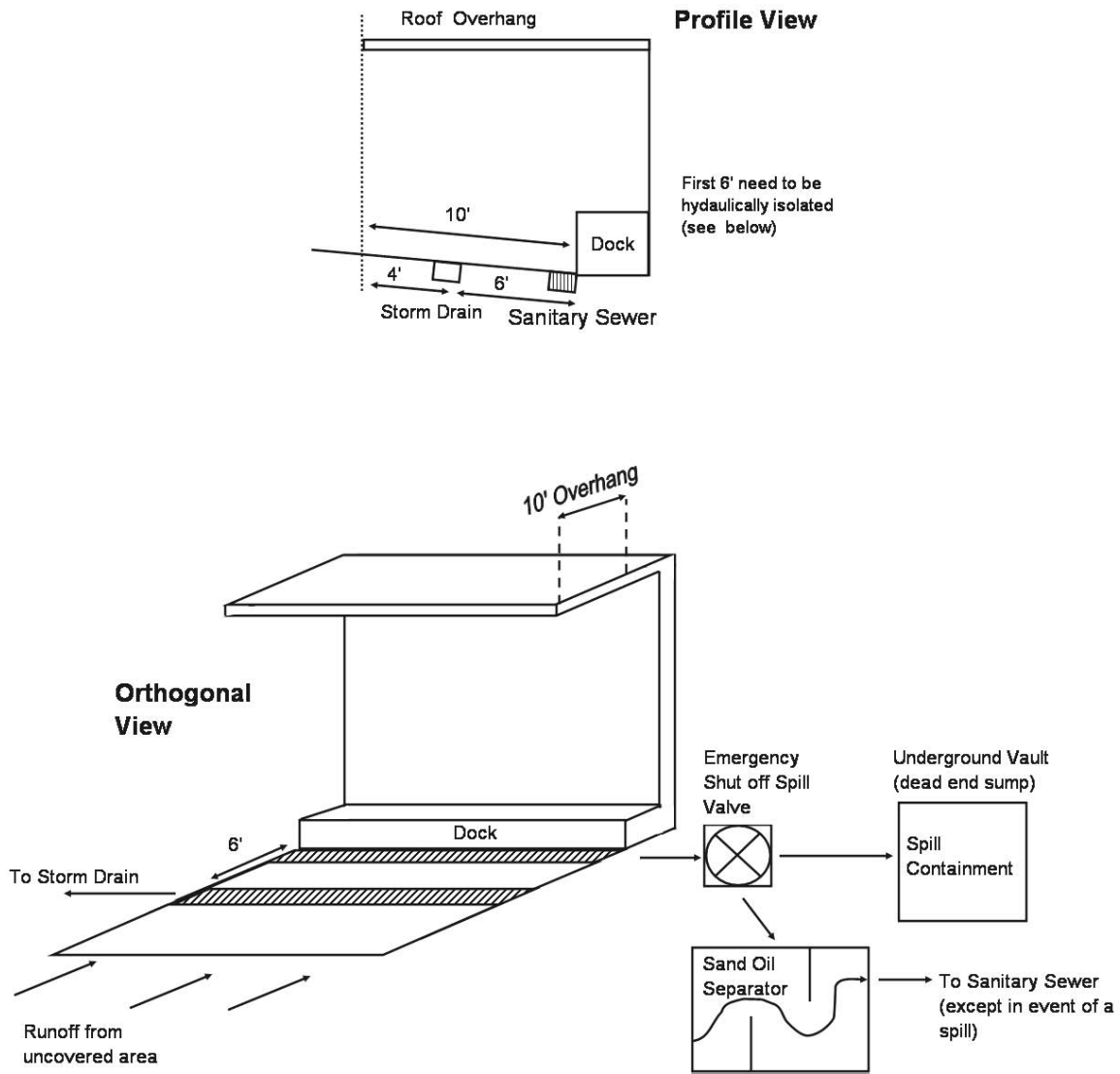

Figure LA-1. Recommended Loading Area Drainage Design

# Outdoor Storage Areas

---

## Purpose

This fact sheet specifies how to locate and design outdoor material storage areas so that materials do not get washed off-site with runoff and become sources of pollutants to the local municipal storm drain system, creeks and rivers. Such materials, including raw, by- and finished products, are not allowed in the storm drain system. Proper design of storage areas will also help ensure that stormwater and other site water does not come into contact with the stored materials and leach out pollutants. Potential pollutants addressed depend on the material stored, but may include toxic compounds, heavy metals, nutrients, suspended solids, and more.



*Covered outdoor storage area.  
Photo: Sacramento County EMD, Water Protection Division*

## Applicability

Refer to Table 3-3 regarding the project land use types that need to comply with this fact sheet. This fact sheet does not address storage of solid and recycling wastes; see the Waste Management Areas fact sheet elsewhere in this chapter.

## Design Requirements

To protect water quality, design outdoor material storage areas as explained in Table OS-1. If possible, determine the types and quantities of materials likely to be stored prior to design.

Design requirements in this fact sheet are intended to supplement (not supersede) those in other codes (such as the Building, Fire, and Zoning Codes and the hazardous waste requirements in Title 22, California Code of Regulations, as applicable). Discuss any potential conflicts with the local permitting agency early in the planning process before proceeding with design. In addition, certain industries are subject to the State's Industrial Stormwater General Permit, which is also intended to protect stormwater quality: see

[http://www.waterboards.ca.gov/water\\_issues/programs/stormwater/gen\\_indus.shtml](http://www.waterboards.ca.gov/water_issues/programs/stormwater/gen_indus.shtml) regarding covered industries and applicable requirements.

## Operation and Maintenance

The design features required by this fact sheet need to be maintained and properly operated. This includes proper handling and disposal of materials which accumulate in a secondary containment area, if applicable. In addition, features may be subject to inspections by local fire and/or sanitary sewer agencies, depending on the configuration.

*Table OS-1. Design Requirements for Outdoor Storage Areas to Protect Water Quality*

Design Feature	Requirement
Size and Location	<ul style="list-style-type: none"> <li>▪ Size the storage area large enough for the expected materials and plan for segregation.</li> <li>▪ Considering planned activities and traffic flow, locate the storage area where it will be convenient but not in the way of truck and vehicle traffic.</li> <li>▪ Locate storage in a secure place to protect against vandalism and minimize accidents.</li> </ul>
Paving	<ul style="list-style-type: none"> <li>▪ Construct the storage area base with a material impervious to leaks and spills. Contact your local permitting agency to determine if gravel surfaces are acceptable under certain conditions (e.g., storage of inert bulk materials).</li> </ul>
Cover	<ul style="list-style-type: none"> <li>▪ Install a roof or other cover acceptable to the local permitting agency that extends beyond the storage area (enough to keep rain out), or use a storage shed or cabinet.</li> <li>▪ If solid bulk materials (such as, wood chips and other landscaping materials, sand, lumber, scrap metal) will be stored and it isn't feasible to cover the storage area, then omit the cover and follow the drainage requirements for uncovered storage areas (see the next section).</li> </ul>
Grading/ Drainage	<ul style="list-style-type: none"> <li>▪ Direct runoff from downspouts/roofs away from storage areas.</li> <li>▪ Hydraulically isolate the area using grades, berms or interceptor drains, to prevent run-on from surrounding areas or the runoff of spills. Refer to other fact sheets in this chapter for various options on how to accomplish this.</li> <li>▪ Drainage Options for uncovered storage areas: (discharge to the storm drain system is not allowed)                             <ul style="list-style-type: none"> <li>○ If liquids (non-flammable, non-combustible) will be stored in the area, gently slope the storage area to drain to a dead-end sump. Accumulated water in the sump must be pumped to the sanitary sewer, an on-site stormwater quality treatment control measure, or land disposal, as appropriate based on the quality of the water and the sanitary sewer permit requirements. Refer to Appendix C for sanitary sewer connection and contact information.</li> <li>○ If solid bulk materials will be stored in the area, slope and arrange the storage area to minimize contact between stormwater and stored materials (such as wood chips, plant materials, and compost) that can leach potential pollutants.</li> </ul> </li> </ul>
Secondary Containment for Bulk Liquids <sup>1</sup>	<ul style="list-style-type: none"> <li>▪ See notes above for liquids.</li> <li>▪ As a general rule, size the secondary containment to accommodate at least 125% of the volume of the largest container or 10% of the volume of all the containers.</li> <li>▪ If liquids will be stored in tanks, approved double-walled tanks can generally be used in lieu of other secondary containment. Verify this with the local permitting agency.</li> </ul>

*Notes: 1. Secondary containment is simply a structure/facility (such as a second container or bermed area) that would catch any spills or leaks from the primary storage container. Secondary containment is considered spill insurance.*

# Outdoor Work Areas

---

## Purpose

This fact sheet pertains to work areas that are outdoors or that open to the outdoors. It specifies how to design such work areas to keep pollutants from contacting stormwater runoff and being carried into the storm drain system or receiving waters. Potential pollutants addressed depend on the work area but include any materials used on site or that could leak from vehicles or equipment. This includes: oil and grease, toxic substances, caustic or acidic substances, heavy metals, sediment, organic matter (depletes oxygen levels as it decays in water) and litter.



*Paved and covered outdoor work area.  
Photo: CASQA, 2003*

## Applicability

Refer to Table 3-3 regarding the project land use types that need to comply with this fact sheet. This fact sheet addresses outdoor processing and manufacturing areas, as well as general “work” areas. Also, this fact sheet includes some requirements specific to vehicle repair areas, since auto repair shops are one of the priority project categories identified by the stormwater regulations (see Table 3-1 in Chapter 3). However, note that the most appropriate location for vehicle repair is indoors. All outdoor facilities will be subject to the approval of the local permitting agency.

## Design Requirements

To protect water quality, use the requirements shown in Table OW-1 when designing work areas that are outdoors or open to the outdoors. The requirements are intended to keep such pollutants from soaking into the ground or reaching the storm drainage system and creeks and rivers. Alternative designs may be approved provided water quality is protected to an equal or greater extent. Check with the local permitting agency for verification.

Design requirements in this fact sheet are intended to supplement (not supersede) those in other codes (such as the Building, Fire, and Zoning Codes and the hazardous waste requirements in Title 22, California Code of Regulations, as applicable). Discuss any potential conflicts with the local permitting agency early in the planning process before proceeding with design. In addition, certain industries are subject to the State’s Industrial Stormwater General Permit, which is also intended to protect stormwater quality:

see [http://www.waterboards.ca.gov/water\\_issues/programs/stormwater/gen\\_indus.shtml](http://www.waterboards.ca.gov/water_issues/programs/stormwater/gen_indus.shtml) regarding industries subject to the rules and applicable requirements.

## Operation and Maintenance

The design features required by this fact sheet need to be maintained and properly operated. This includes proper handling and disposal of materials which may accumulate in containment devices/areas, ensuring that covers are not removed from outdoors work areas, and drains do not become disconnected. In addition, features may be subject to inspections by local fire and/or sanitary sewer agencies, depending on the configuration.

*Table OW-1. Design Requirements for Outdoor Work Areas to Protect Water Quality*

Design Feature	Requirement
Paving	<ul style="list-style-type: none"> <li>▪ Pave the work area with an impervious surface. Use Portland cement concrete (or equivalent smooth impervious surface) where vehicles or equipment will be repaired or hazardous materials could be used.</li> </ul>
Cover	<ul style="list-style-type: none"> <li>▪ Conduct vehicle maintenance/repair indoors. Cover any other work areas that are not fully enclosed.</li> </ul>
Grading/Drainage	<ul style="list-style-type: none"> <li>▪ Locate the work area away from storm drain inlets.</li> <li>▪ Hydraulically isolate the area using grades, berms or interceptor drains, to prevent run-on from surrounding areas or the runoff of spills. Refer to other fact sheets in this chapter for various options on how to accomplish this.</li> <li>▪ Design a repair/maintenance bay drainage system to capture all wash water, leaks, and spills. Connect drains to an oil/water separator and drain to the sanitary sewer. Direct connection to the storm drain system is prohibited.</li> <li>▪ Drain other work areas addressed by this fact sheet to a containment area, sanitary sewer, or pretreatment facility (which in turn discharges to the sanitary sewer or storm drain as approved by the local permitting agency), as appropriate. The appropriate drainage destination will depend on potential pollutants and whether it is feasible to cover the work area. Discuss the project with the local permitting agency to determine the best solution, and whether a shut-off valve or other spill control device is warranted.</li> <li>▪ If the site will include air compressors or other equipment that automatically produces small amounts of contaminated blowdown water, connect the blowdown to the sanitary sewer, subject to approval of the local permitting agency.</li> <li>▪ Where processing operations are planned that will release wash water or process liquids, drain the area to the sanitary sewer (assuming approval is obtained).</li> <li>▪ See Appendix C for sanitary sewer connection and contact information.</li> </ul>
Spill Control	<ul style="list-style-type: none"> <li>▪ Some agencies may require a shut-off/diversion valve, drain plug, or drain cover, to keep spills from entering the storm drainage system. Check with local permitting agency.</li> <li>▪ Provide secondary containment structures where wet material processing occurs, to contain any spills or unplanned releases. Double wall containers can only be used with permission from local permitting agency.</li> </ul>
Signage	<ul style="list-style-type: none"> <li>▪ If the area drains to an inlet with a shut-off valve, post a sign locating the valve and explaining its operation.</li> </ul>



# Storm Drain Inlet Markings and Signage

---

## Purpose

This fact sheet provides details about permanent “No dumping-drains to creek/river” messages at storm drain inlets and “No dumping” signs at public access points to channels and creeks on the development project site, where applicable. Storm drain markings are intended to help stop illegal dumping by alerting people that the drain leads directly to a waterbody and dumping is prohibited. Signs at access points to creeks and channels serve as reminders that dumping is illegal at these locations.



*Inlet marking directly in concrete  
Photo source: County of Sacramento*

## Applicability

As indicated in Table 3-3, permanent storm drain inlet markings are required on all new drain inlets (also known as catch basins) installed in development/ redevelopment projects. Signs are also required at public access points to any creeks or drainage channels within or adjacent to the site.



*Pre-fabricated inlet marker  
Photo source: County of Sacramento*

## Design Requirements

To protect water quality, follow the requirements shown in Table SD-1 to create consistent “no dumping” messages at storm drain inlets and public access points at creeks and channels.

## Operation and Maintenance

The legibility of storm drain inlet messages and signs must be maintained to ensure effective pollution prevention over time.

*Table SD-1. Design Requirements for Storm Drain Inlet Markings and Signage*

Design Feature	Requirement
Location	<ul style="list-style-type: none"> <li>▪ Identify all storm drain inlets on the improvement plans and indicate they must be marked with appropriate storm drain messages.</li> <li>▪ Locate the message on each inlet as described in the next section.</li> </ul>
Message Layout and Content	<ul style="list-style-type: none"> <li>▪ Follow the message layout, content, and other specifications provided by the local permitting agency. Each agency may have its own design. See Figure SD-1 for an example detail.</li> <li>▪ For signs posted at access points to waterways, consult the local permitting agency for their required/preferred message and style.</li> <li>▪ Alternatively, obtain approval from the local jurisdiction for a different layout/message that clearly prohibits dumping using words or graphical icons.</li> <li>▪ Consider the use of bilingual messages where appropriate based on local population.</li> </ul>
Method of Application	<ul style="list-style-type: none"> <li>▪ Permanently apply the message at storm drain inlets by stamping it in concrete, affixing as a tile or cast-iron plate, or using an alternative approach approved by the local jurisdiction.</li> <li>▪ For area drain markers, make sure any inset tiles or plates are flush with the surface of the inlet to avoid a tripping hazard.</li> <li>▪ Consider permanently affixing signs at access points to creeks and channels.</li> </ul>

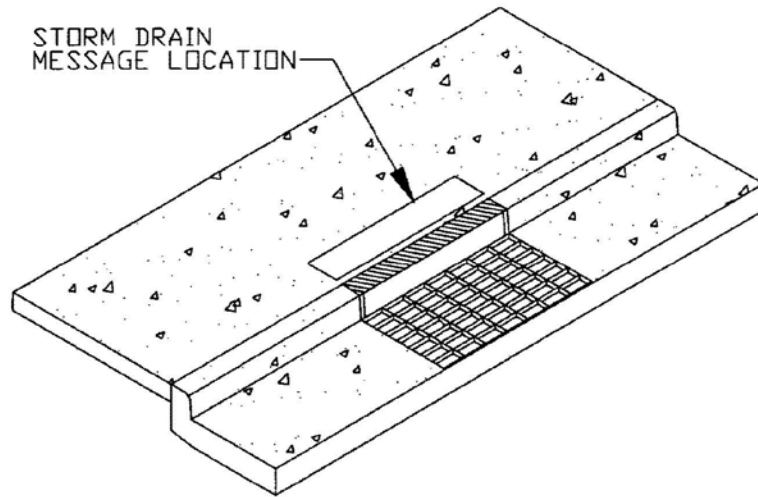

**NO DUMPING!**  
**FLOWS TO RIVER** 

**NO DUMPING!**  
**FLOWS TO CREEK** 

**NO DUMPING**  **I LIVE**  
**DOWNSTREAM**

**NOTES:**

1. STORM DRAIN MESSAGE SHALL BE APPLIED IN SUCH A WAY AS TO PROVIDE A CLEAR, LEGIBLE IMAGE.
2. STORM DRAIN MESSAGE SHALL BE PERMANENTLY APPLIED DURING THE CONSTRUCTION OF THE CURB AND GUTTER USING A METHOD APPROVED BY THE LOCAL AGENCY.
3. FOR AREA DRAIN INLETS, STORM DRAIN MESSAGE SHALL BE PLACED ADJACENT AND PARALLEL TO THE LONG AXIS OF THE DRAIN.
4. LETTERS SHALL BE 1-1/2" IN HEIGHT. DIMENSIONS OF STORM DRAIN MESSAGE SHALL NOT EXCEED 12" X 33".
5. IF THE MESSAGE IS STAMPED IN CONCRETE, THE DEPTH SHOULD BE APPROXIMATELY 0.25".
6. IF AN ALTERNATIVE STORM DRAIN MESSAGE IS PROPOSED, IT SHALL BE APPROVED BY THE LOCAL AGENCY.

*Figure SD-1. Storm Drain Inlet Message*

THIS PAGE INTENTIONALLY LEFT BLANK

# Wash Areas

---

## Purpose

This fact sheet specifies how to locate and design permanent wash areas for vehicles and equipment (including restaurant mats) so that wash water does not enter the storm drain system and receiving waters. Wash water typically carries an array of pollutants harmful to the aquatic environment. Potential pollutants depend on what is being washed but typically include oil and grease, metals, suspended solids, soluble organics, food waste, fats/oils/greases from food, and/or detergents or other cleaning chemicals.



*Central Wash Area in Apartment Complex Parking Lot.  
Source: City of Palo Alto, California*

## Applicability

Table 3-3 indicates the project land use types that need to comply with this fact sheet if a permanent wash area (including steam cleaning) is planned for the development project. In these cases, the wash area must be designed according to the design requirements specified in this fact sheet. Some permitting agencies may require the inclusion of a permanent designated wash area for some land uses. Check with the local permitting agency for verification. This fact sheet also pertains to the washing of equipment in outdoor areas, particularly, restaurant mats and similar equipment, which can send food waste and fats, oils and grease to the storm drain system.

## Design Requirements

To protect water quality, design equipment and vehicle wash areas following the requirements in Table WA-1. Design requirements on this fact sheet are intended to supplement (not supersede) those in other codes. Discuss any potential conflicts with the local permitting agency early in the planning process before proceeding with design.

## Operation and Maintenance

The design features required by this fact sheet need to be maintained and properly operated. In addition, actuated valve installations may be subject to inspections by the local sanitary sewer agency. See Appendix C for sanitary sewer connection and contact information.

Table WA-1. Design Requirements for Equipment and Vehicle Wash Areas to Protect Water Quality

Design Feature	Requirement
<i>Small Equipment Wash Areas – Applies to washing of restaurant mats and other kitchen supplies, as well as small equipment used at other commercial facilities.</i>	
Size and Location	<ul style="list-style-type: none"> <li>▪ Locate the designated wash area indoors.</li> <li>▪ Provide a sink or contained wash area large enough to accommodate the largest item that will typically be washed.</li> </ul>
Drainage and Pretreatment	<ul style="list-style-type: none"> <li>▪ Drain the sink/wash area to the sanitary sewer (or a zero-discharge water recycling system, subject to approval of permitting agency).</li> <li>▪ For food-handling facilities: equip the wash area with a grease interceptor to meet the approval of the applicable permitting agency.</li> </ul>
<i>Vehicle and Large Equipment Wash Areas</i>	
Size and Location	<ul style="list-style-type: none"> <li>▪ Locate the wash area such that access is from paved areas only (to prevent tracking of sediment).</li> <li>▪ Size vehicle and equipment wash areas to extend at least 4 ft. in all directions around the largest piece of equipment/vehicle to be washed.</li> <li>▪ For vehicle wash areas where vehicle size is unknown, size the wash area to be at least 25 ft. long and 15 ft. wide.</li> </ul>
Paving	<ul style="list-style-type: none"> <li>▪ Pave the wash area with asphalt or concrete.</li> </ul>
Cover	<ul style="list-style-type: none"> <li>▪ Cover the entire wash area with a roof or other type of approved permanent canopy. For covers 10 feet high or less, extend at least 3 feet beyond the perimeter of the hydraulically isolated wash area. For covers higher than 10 feet, extend at least 5 feet beyond the wash area.</li> <li>▪ For new development in infill areas, or for redevelopment projects where there is no space to add a covered wash area, or for airport facilities, a diversion valve is required (see the Grading/Drainage section of this table).</li> <li>▪ New facilities servicing oversized vehicles (bus, fire trucks) are required to provide a cover. Redevelopment of such facilities should consider addition of a shut-off/diversion valve if a cover is not feasible.</li> </ul>
Grading/Drainage – General	<ul style="list-style-type: none"> <li>▪ Hydraulically isolate the wash area to contain the wash water and prevent runoff from leaving the area and run-on from surrounding areas from entering the wash area. Use grade breaks, berms, or interceptor drains (around the perimeter or in the entrance and exit zones) to accomplish this.</li> </ul>
Drainage – Covered Areas	<ul style="list-style-type: none"> <li>▪ Connect the covered wash area to an appropriate pretreatment device (e.g., oil/water separator), then to the sanitary sewer.</li> <li>▪ Alternatively, install a zero-discharge water recycling system.</li> <li>▪ For any of these options, first obtain approval from the applicable permitting agency. See Appendix C for sanitary sewer connection and contact information.</li> </ul>

Design Feature	Requirement
Drainage – Cover not feasible	<ul style="list-style-type: none"> <li>▪ When a cover is not feasible (see “cover” discussion earlier in this table), connect the hydraulically isolated area to the storm drain system and equip the drainage system with a shut-off/diversion valve that can temporarily redirect polluted wash water to the sanitary sewer when washing activities are taking place.</li> <li>▪ Various types of actuated valve configurations have been used in the Sacramento area for truck washing areas and children’s water parks. Diversion valves could be triggered when the water supply faucet is turned on or by a rain gage. Check with the local permitting agency early in the planning process before proceeding with design of this type of system.</li> <li>▪ See Appendix C for sanitary sewer connection and contact information.</li> </ul>
Trash Receptacle	<ul style="list-style-type: none"> <li>▪ Locate a covered garbage receptacle within or immediately adjacent to a vehicle wash area to provide a convenient means for people to dispose of trash and keep the materials out of the storm drain system.</li> </ul>
Signage	<ul style="list-style-type: none"> <li>▪ Post signs that clearly identify the facility’s intended use for employees and tenants.</li> <li>▪ Post signs that prohibit: <ul style="list-style-type: none"> <li>○ the use of cleaning products that contain hazardous substances (hydrofluoric acid, muriatic acid, sodium hydroxide, bleach, etc.) and can turn wastewater into hazardous waste</li> <li>○ the use of specific cleaning products incompatible with any pre-treatment device (check with local permitting agency)</li> <li>○ dumping of vehicle fluids in wash areas</li> <li>○ engine/car repair in the wash area</li> <li>○ dumping in storm drains</li> </ul> </li> </ul>

THIS PAGE INTENTIONALLY LEFT BLANK



# Waste Management Areas

---

## Purpose

This fact sheet specifies how to design waste and recycling storage areas so that they aren't sources of pollutants to the storm drainage system and receiving waters. A properly designed waste/recycling storage area keeps rain, runoff, and other site water from leaching away pollutants; minimizes the chance of spills and leaks; and prevents any spilled or leaked wastes from entering the storm drainage system. Potential pollutants from waste include fats/oils/greases (from food), particulates, organic matter, toxic chemicals, and more.



*Trash enclosure with covered dumpster.  
Photo: City of Folsom*

## Applicability

Refer to Table 3-3 regarding the project land use types that need to comply with this fact sheet. The design requirements provided in this fact sheet are primarily intended for new development. If applied to significant redevelopment, the requirements would only apply in the case of complete redesign of the portion of the facility involving the waste management/trash enclosure area(s).

## Design Requirements

To protect water quality, design waste and recycling storage areas as explained in Table WM-1. Design requirements in this fact sheet are intended to supplement (not supersede) those in other codes (such as the Building, Fire, and Zoning Codes and the hazardous waste requirements in Title 22, California Code of Regulations, as applicable). Discuss any potential conflicts with the local permitting agency early in the planning process before proceeding with design. In addition, check with the appropriate waste management agency regarding design or access requirements.



*Covered Storage for Waste and Recycling  
Bins and Compactor, Pleasanton,  
California  
Photo: CKB Environmental*

## Operation and Maintenance

The design features required by this fact sheet need to be maintained and properly operated. This includes regular maintenance of the grease interceptor and handling and disposal of materials which

## Waste Management Areas

accumulate in the interceptor, and maintenance of covers and sanitary sewer connections, if applicable.

*Table WM-1. Design Requirements for Waste Management Areas to Protect Water Quality*

Design Feature	Requirement
Location and Enclosure – General	<ul style="list-style-type: none"> <li>Design an enclosed area for waste and recycling storage and collection on the site so that containers cannot be knocked over and where unauthorized use or vandalism is unlikely. This will help keep debris from being blown off site and pollutants from entering the storm drain system.</li> </ul>
Location/Access – Enclosure Area	<ul style="list-style-type: none"> <li>Provide adequate room for waste collection trucks to pick up and empty dumpsters to minimize chance of accidents and spillage. Check with the local solid waste agency for access standards.</li> <li>In the absence of local standards, design the enclosure to have direct access for collection trucks, meaning the truck can drive directly at the bin and insert the forks into the sides of the bin. A minimum straight approach of 50-65 feet is recommended to line up directly with the bin.</li> </ul>
Paving	<ul style="list-style-type: none"> <li>Pave the waste/recycling storage area with Portland Cement Concrete.</li> </ul>
Space and Waste Segregation	<ul style="list-style-type: none"> <li>Provide ample space inside the waste management area for bins to contain the maximum amount of expected waste and recycling matter to be generated at the facility, considering the typical waste collection schedule. Check with the local solid waste agency for detail drawings if available.</li> <li>For areas designated to contain tallow bin(s), provide a separate enclosed area for storage of the tallow bin, segregated from the area used to store solid and recycling wastes, and covered if acceptable to permitting agency (some agencies may not want solid waste enclosures covered [see discussion below], but will allow tallow bin enclosures to be covered due to different loading practices).</li> </ul>
Cover	<ul style="list-style-type: none"> <li>Provide a cover for the entire waste area if acceptable to permitting agency. Some local waste haulers may not allow a cover, due to vertical clearance/accessibility needs for front loading trucks.</li> <li>If a cover will be installed, check with local fire department about possible sprinkling requirements.</li> </ul>
Grading/Drainage	<ul style="list-style-type: none"> <li>Direct runoff from roof downspouts away from the waste/recycling storage area.</li> <li>Locate the waste management area at least 35 feet from the nearest storm drain inlet. The intention is to deter employees/tenants/contractors from directing wash water to the storm drain system with a hose or pressure washer.</li> <li>Hydraulically isolate the area; this can be achieved by reverse grading at the perimeter, perimeter curbing or berming, or the use of perimeter or area drains to collect and divert runoff.</li> </ul>
Sanitary Sewer Connection	<ul style="list-style-type: none"> <li>If acceptable to the permitting agency, connect the hydraulically isolated area to the sanitary sewer via a trench drain at the back of the enclosure or similar, to facilitate proper disposal of polluted wash water. Check with the local waste management agency for detail drawings if available.</li> <li>Provide pretreatment with an approved grease interceptor prior to discharge to the sanitary sewer. Check with the local sanitary sewer permitting agency for specifics and approval. Note that the Plumbing Code limits the number of connections to a single grease interceptor at a facility.</li> </ul>

Design Feature	Requirement
	<ul style="list-style-type: none"> <li>▪ See Appendix C for sanitary sewer connection and contact information.</li> </ul>
Signage	<ul style="list-style-type: none"> <li>▪ Post signs inside the enclosure and/or on the bins prohibiting the disposal of liquids and hazardous materials therein.</li> <li>▪ Consider posting signs on the inside of the enclosure walls to educate employees and tenants about proper wash down procedures (procedures will vary depending on whether or not the area is connected to the sanitary sewer system).</li> </ul>
<p><i>These requirements are intended to supplement, not supersede, those found in other codes (e.g., building, plumbing, fire, hazardous waste). If conflicts are identified, consult with the local permitting agency and other agencies as needed (e.g., fire, sanitation district) for resolution.</i></p>	

THIS PAGE INTENTIONALLY LEFT BLANK

# Chapter 5. Hydromodification Management, Low Impact Development, and Treatment Control Measures

---

## Introduction

Hydromodification management, LID, and treatment control measures are designed to meet distinctly different regulatory requirements. Those different regulatory requirements can be summarized as follows:

- Hydromodification Management Requirements – Address changes to runoff characteristics from urbanization and other sources that would otherwise result in the artificially altered rate of erosion or sedimentation within downstream natural channels.
- Low Impact Development Requirements – Address more holistic environmental objectives associated with restoration of the natural hydrologic regime and reduce pollution in runoff.
- Treatment Requirements – Address impacts to stormwater pollutant concentration and/or pollutant load that would otherwise result from urbanization.

Each of these requirements and the corresponding design approach necessary to demonstrate compliance is discussed in greater detail within this chapter. The design practitioner has a number of optional control measures at his/her disposal that can satisfy these requirements on an individual or collective basis. The suitability of each control measure to address one or more of the requirements discussed above varies based on its functionality. A summary of the allowable application of each control measure to address hydromodification, LID, and/or treatment control requirements is shown in Table 5-1. Notice the high correlation between the ability of LID measures to simultaneously address hydromodification management and treatment control requirements. In order for proprietary devices to be counted as LID, project specific calculations must be provided to demonstrate volume reduction to the satisfaction of the reviewing agency.

Table 5-1 Summary of Control Measure Functionality

✓ Acceptable Option

“RR” Runoff Reduction, used in combination with other measures

Control Measure	Appropriate for Compliance With		
	Hydromodification Management Standards	Low Impact Development Implementation	Treatment Control
Alternative Driveways	RR	✓	RR
Capture and Re-Use	RR	✓	RR
Compost-Amended Soil	RR	✓	RR
Constructed Wetland Basin	✓		✓
Disconnected Pavement	RR	✓	RR
Disconnected Roof Drains	RR	✓	RR
Green Roof	RR	✓	✓
Infiltration Basin	✓		✓
Infiltration Trench	✓	✓	✓
Interceptor Trees	RR	✓	RR
Porous Pavement	RR	✓	RR
Sand Filter (Austin Sand Filter)	✓		✓
Bioretention Planter (Flow-Through)	✓	✓	✓
Bioretention Planter (Infiltration)	✓	✓	✓
Underground Storage (Tanks, Vaults, etc.)	✓		
Vegetated Filter Strip		✓	
Vegetated Swale		✓	✓
Water Quality Detention Basin	✓		✓
Proprietary Devices			✓

Note: Runoff Reduction (RR) measures contribute to the overall required mitigation, but are not standalone measures and need to be combined with appropriate treatment controls or hydromodification management controls as needed.

## Hydromodification Control Principles and Applicability

As development occurs, much of the natural vegetated areas are replaced by impervious surfaces such as roofs, streets, and parking lots. This increase in impervious area typically results in a corresponding increase in the volume, velocity, and peak flow rate of runoff discharged from the site, as well as a reduction in bed material to downstream channels and streams. Such artificially

created changes to runoff characteristics are known as hydromodification and can result in accelerated erosion or sediment deposition within downstream natural channels.

Hydrologic characteristics can also be impacted as a result of improvements to stormwater conveyance or detention facilities. Although stormwater detention facilities can lessen peak rates to those of natural conditions, they are not effective in significant reduction of stormwater volume. As such, stormwater detention facilities require proper design procedures to ensure that they successfully mitigate impacts to the duration of geomorphically significant flow. Forthcoming sections within this chapter are devoted to discussion of proper design procedures.

Hydromodification management can be assessed using continuous simulation hydrologic modeling (as opposed to a single event as typically used for flood control design). Hydromodification management requirements are based on the Sacramento Stormwater Quality Partnership (SSQP) Hydromodification Management Plan (HMP) originally developed in 2011 and revised in February 2013.

Figure 5-1 is a flowchart that illustrates the process to determine the applicability of the hydromodification management requirements for a project. The exemptions are summarized below and shown graphically on Figure 5-2, Applicability Map<sup>1</sup> (additional background information for the exemptions is available within the [Sacramento Stormwater Quality Partnership HMP](#)).

### Projects Located in an Exempted Area

Some projects may be exempt from hydromodification mitigation requirements based on the conditions in the watershed or the receiving waters. Projects are exempt from hydromodification mitigation requirements if the project:

- Drains directly to the Sacramento or Lower American River:  
Projects discharging directly, or through exempted drainage channels, or through underground drainage conveyance system and pump stations, to the Lower American River or Sacramento River will not be subject to hydromodification management requirements.
- Area is within a highly developed watershed:  
The threshold for a "highly developed" watershed in Sacramento County is a watershed with 5% or less developable area.
- Drains to an exempted Special drainage area:  
Three drainage areas in Sacramento County have been investigated and determined not to be subject to hydromodification requirements: City of Sacramento North Natomas Basin, Metro Air Park in unincorporated Sacramento County, and the Franklin Creek (formerly known as Shed B) watershed in the City of Elk Grove. Additional information about why these three areas are exempt can be found in Section 3.2.4 of the HMP.

---

<sup>1</sup> Full size map available at: [http://www.beriverfriendly.net/docs/files/File/HMP/HMP%20Map%20Fig%203-7\\_FULLSIZE.pdf](http://www.beriverfriendly.net/docs/files/File/HMP/HMP%20Map%20Fig%203-7_FULLSIZE.pdf)

## Municipal Agency Projects

The following municipal agency projects may be exempted from implementation of hydromodification controls:

*“Projects that are replacement, maintenance, or repair of the Permittees’ existing flood control facilities, storm drains, public utilities, or transportation network.” [2016 MS4 Permit, Attachment J, Provision F.2.i.ii.(1)]*

Existing flood control facilities includes debris basins, retention/detention basins, levees, and flood control channels. Existing storm drains include storm drain pipes and associated facilities, such as catch basins, inlets, curbs, gutters, ditches, man-made channels, water quality features, and structural BMPs. Existing public utilities includes electricity, natural gas, sewage treatment, waste collection/management, telecommunications, water, and other services provided to municipal residents. Transportation network includes structures that permit vehicular or other movement of people or goods, including roads and streets, sidewalks, pedestrian ramps, bike lanes, railways, and transit lines.

Replacement, maintenance, or repair includes:

- cleaning,
- trenching and resurfacing associated with utility work,
- grinding or resurfacing of impervious surfaces that does not result in exposing underlying subgrade material (dirt),
- pothole repair, and
- similar activities with the purpose of ensuring proper operation of flood control facilities, storm drains, public utilities, or transportation network elements.

## Prior Approved Projects

Prior approved projects will not be subject to hydromodification management requirements **and** low impact development requirements because the design plans and specifications (including drainage design) have already been completed and it will be unreasonable and cost prohibitive to require a project applicant to re-design the project.

A project shall meet one of the following criteria to be considered an “approved project”:

1. A project will be exempt from HMP and LID requirements if the project’s site design is approved or established by one of the following methods no later than July 1, 2018:
  - a. The site has a complete application submitted for a tentative map to construct a single-family subdivision; or
  - b. The site has an approved Plan Review, Special Permit or Conditional Use Permit, Design Review/Preservation Review entitlement; or
  - c. The project has a complete building permit application submitted; or



- d. The project has a set of improvement plans submitted; or
  - e. A project being issued a new building permit to complete work commenced under a prior permit may be considered exempt from HMP requirements at the discretion of the local Permitting Agency.
  - f. A Project in a large specific or community plan area that has a drainage master plan approved on or after July 1, 2017.
2. A project discharging directly to a segment of a channel or creek with permitted improvements under a 404 permit or 401 certification from the relevant Federal or State regulatory agencies. The applicant's 404 permit and 401 certification must be currently valid or obtained no later than July 1, 2018. This exemption does not apply for projects with 404 permits or 401 certifications that require hydromodification management.
  3. A public agency project for which design has been completed (final bid documents submitted) and/or a contract has been advertised no later than July 1, 2018.

### Priority Projects

Priority projects listed in Table 1-2 will be subject to hydromodification management requirements. Refer also to Table 3-3 of this manual.

### Discharges Directly to Exempted Channels

Projects discharging to creeks or channels meeting one or more of the following characteristics will not be subject to HMP requirements:

- All surfaces of the channel (bed and both banks) have a continuous erosion resistant lining of concrete, stone (rip-rap), permanent synthetic turf reinforcement fabrics, or other permanent material.
- The channel was constructed for the sole purpose of flood and stormwater conveyance in an area where natural stream channels did not historically exist.
- The drainage channel was designed and constructed with permissible velocity according to the City of Sacramento's Storm Drainage Design Standards (City of Sacramento, 2009).
- The channel was designed and constructed in accordance with the National Resource Conservation Service (NRCS) Part 654 Stream Restoration Design National Engineering Handbook, Chapter 8 Threshold Channel Design 654.0803 Allowable Velocity Method (NRCS, 2007), which provides guidance on stable channel design.

Potential exemption from the hydromodification management requirements, to be determined on a case-by-case basis, will be considered for projects discharging to creeks or channels where Federal or local levee projects have been constructed, including the construction of new concrete floodwalls on banks, excavation and reshaping of the creeks and associated improvements. Federal project levees or structures currently identified by the Sacramento Area Flood Control Agency (SAFCA) that meet this exemption criteria include the South Sacramento Streams (Morrison Creek Stream Group). The

South Sacramento Streams Group includes Morrison Creek, Florin Creek, Elder Creek and Unionhouse Creek located in the southern portion of the Sacramento urbanized area, which has historically been vulnerable to flooding. The U.S. Army Corps of Engineers, the Central Valley Flood Protection Board, and SAFCA were authorized to improve these creeks and channels in the South Sacramento Streams Group and the project consists of levee improvements starting south of the town of Freeport and running easterly along the southern edge of the urbanized area. The upgrades to the channels and creeks in this area intend to significantly improve the flood protection to the community by construction of new concrete floodwalls on banks, excavation and reshaping of the creeks and associated improvements. These in-stream alternations have prepared the creeks for the potential hydromodification impact, i.e. erosion from additional runoff.

These exemption criteria do not apply to channels that the local flood control authority may deem undersized or incised for flood control purposes. Refer to the local flood control authority for more information.

### Redevelopment Projects

The HMP exemption will be provided to redevelopment projects (e.g., infill) that do not increase the effective impervious area or decrease the infiltration capacity of pervious areas compared to the pre-project conditions.

Infill projects are those that meet all the following criteria as defined below, as determined by the permitting authority:

1. The project is consistent with the applicable general plan designation and all applicable general plan policies as well as with applicable zoning designation and regulations.
2. The proposed development occurs on a project site of no more than eight acres in size and is substantially surrounded by urban uses.
3. The project site has no value as habitat for endangered, rare or threatened species.
4. Project site is located within 1/2 mile of a major transit stop identified by Sacramento Area Council of Governments (SACOG) Metropolitan Transportation Plan (MTP 2035).

Figure 5-1 Hydromodification Mitigation Applicability Flow Chart

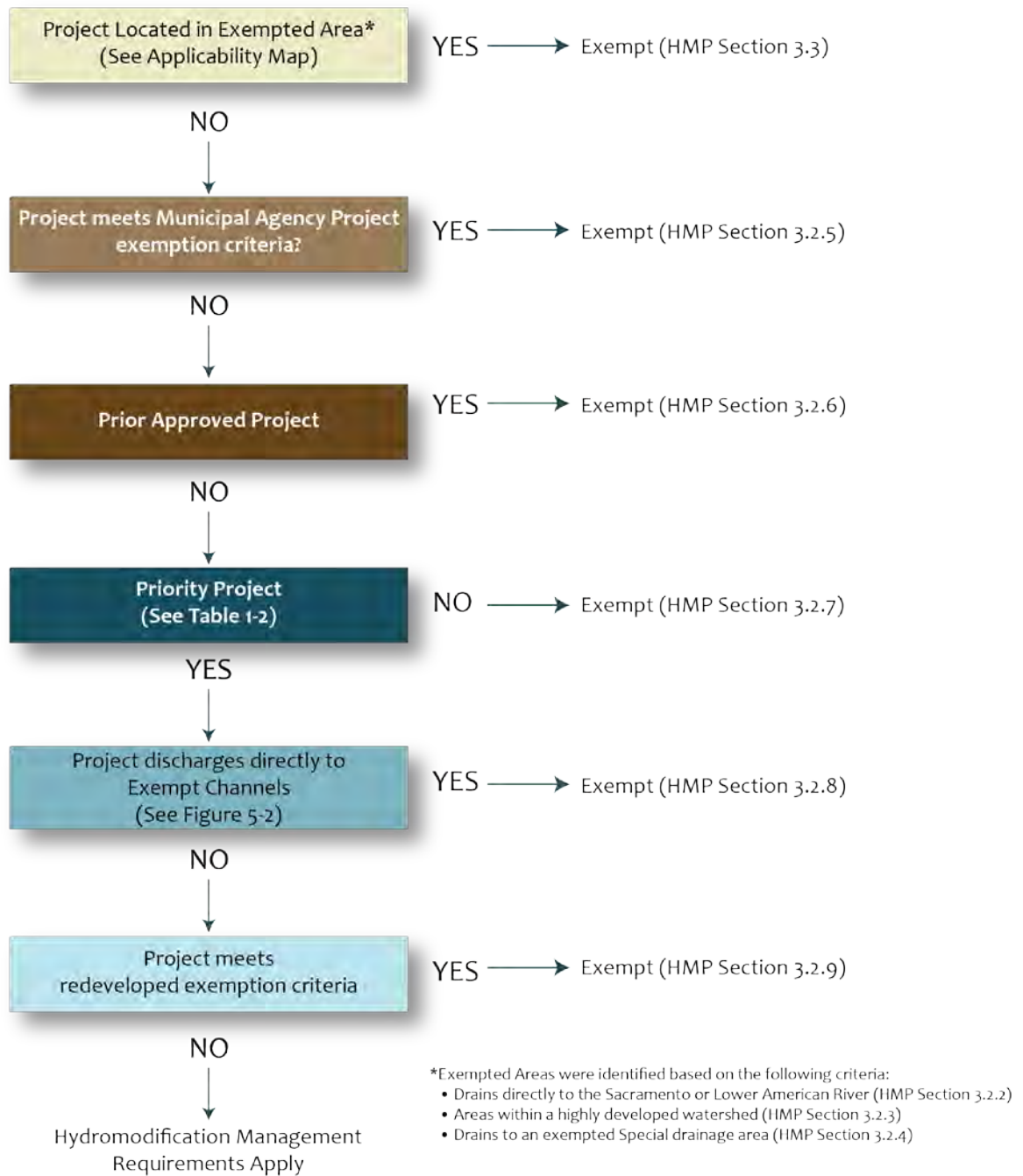
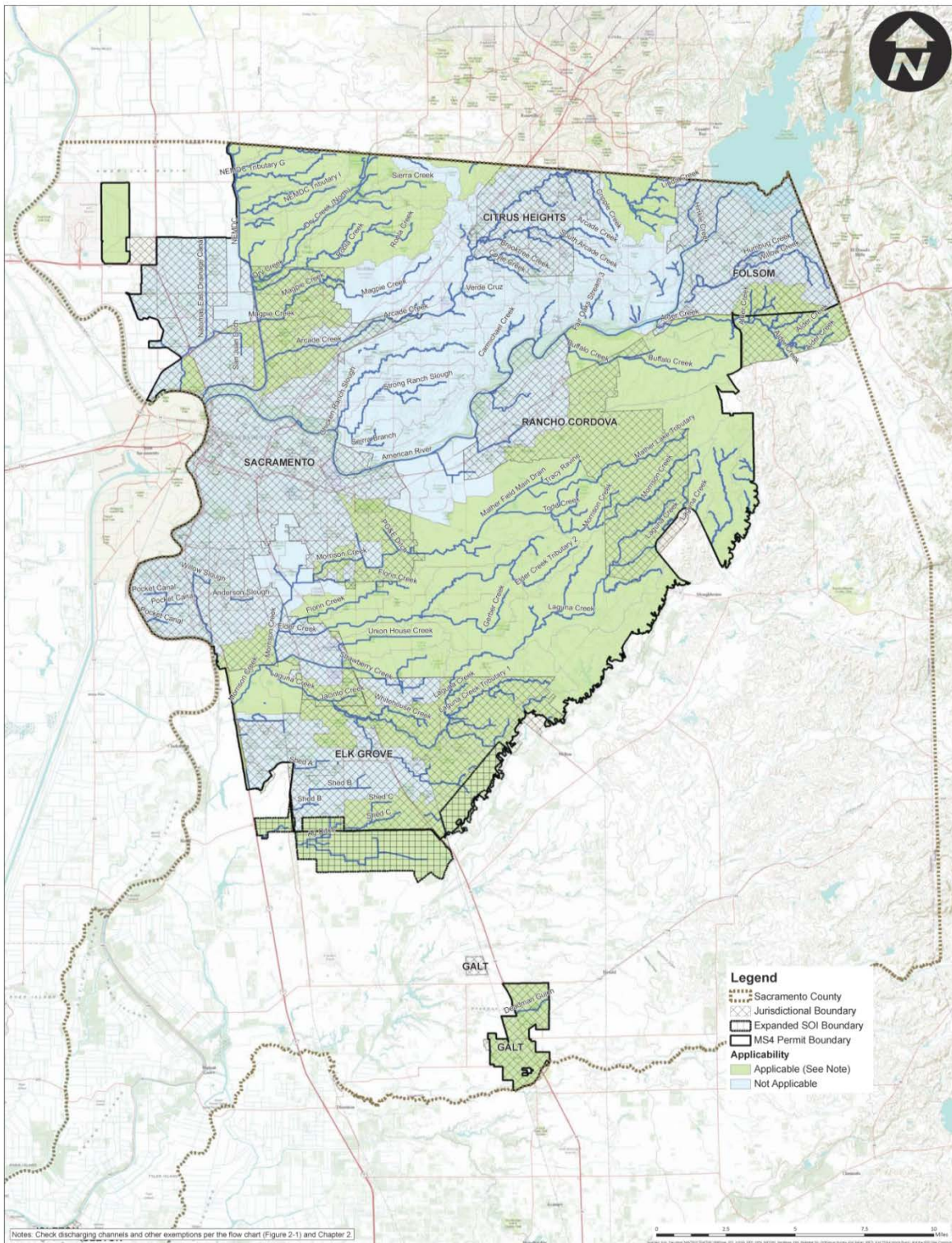

Figure 5-2 Applicability Map



[Click here to link to Figure 3-1, Identifying Stormwater Quality Requirements for New Development and Redevelopment Projects.](#)

Click on this link for a higher resolution copy of the Applicability Map:

<http://www.beriverfriendly.net/Newdevelopment/>

## Selecting Hydromodification Controls for Your Project

If hydromodification control measures are required for your project, the answers to the following questions will help you determine the appropriate control measure(s) for your unique conditions:

- **How much space is available** on the project site for a hydromodification control facility?  
Refer to the fact sheets at the end of this chapter to determine the space requirements for the various types of hydromodification control measures. Consider that some facilities can be integrated into the landscaping planned for the site. Also, although underground facilities do not take up as much space, they can be more costly to construct and maintain.
- What are the **site conditions and associated limitations** on use of stormwater quality hydromodification control measures for this property?  
As described in the fact sheets at the end of this chapter, the selection and design of stormwater hydromodification control measures is largely dependent on soils, topography/slope and other natural site features.
- What **level of maintenance** will the property owner be capable and willing to conduct as long as he/she owns the property?  
Consider the short and long-term maintenance needs of the hydromodification control measures (as described on the fact sheets at the end of this chapter) and whether or not the property owner can agree to those requirements. The permitting agencies in the Sacramento Region require that the property owner sign a maintenance agreement or obtain a permit to ensure long-term maintenance. Such maintenance agreements require reconstruction or replacement of the feature when it fails to function properly. For informational purposes, projected lifespan information is provided for the various control measures in Appendix B.

## Designing Hydromodification Controls

The performance criteria from the Sacramento HMP are as follows:

**Flow duration control** - For flow rates ranging from 25% or 45% of the pre-project 2-year recurrence interval event ( $0.25Q_2$  or  $0.45Q_2$ ) to the pre-project 10-year runoff event ( $Q_{10}$ ), the post-project discharge rates and durations shall not deviate above the pre-project rates and durations by more than 10% over more than 10% of the length of the flow duration curve (see Figure 5-3). The specific lower flow threshold will depend on results from the channel susceptibility assessment.

Figure 5-3 Visual Demonstration of the HMP Performance Criteria

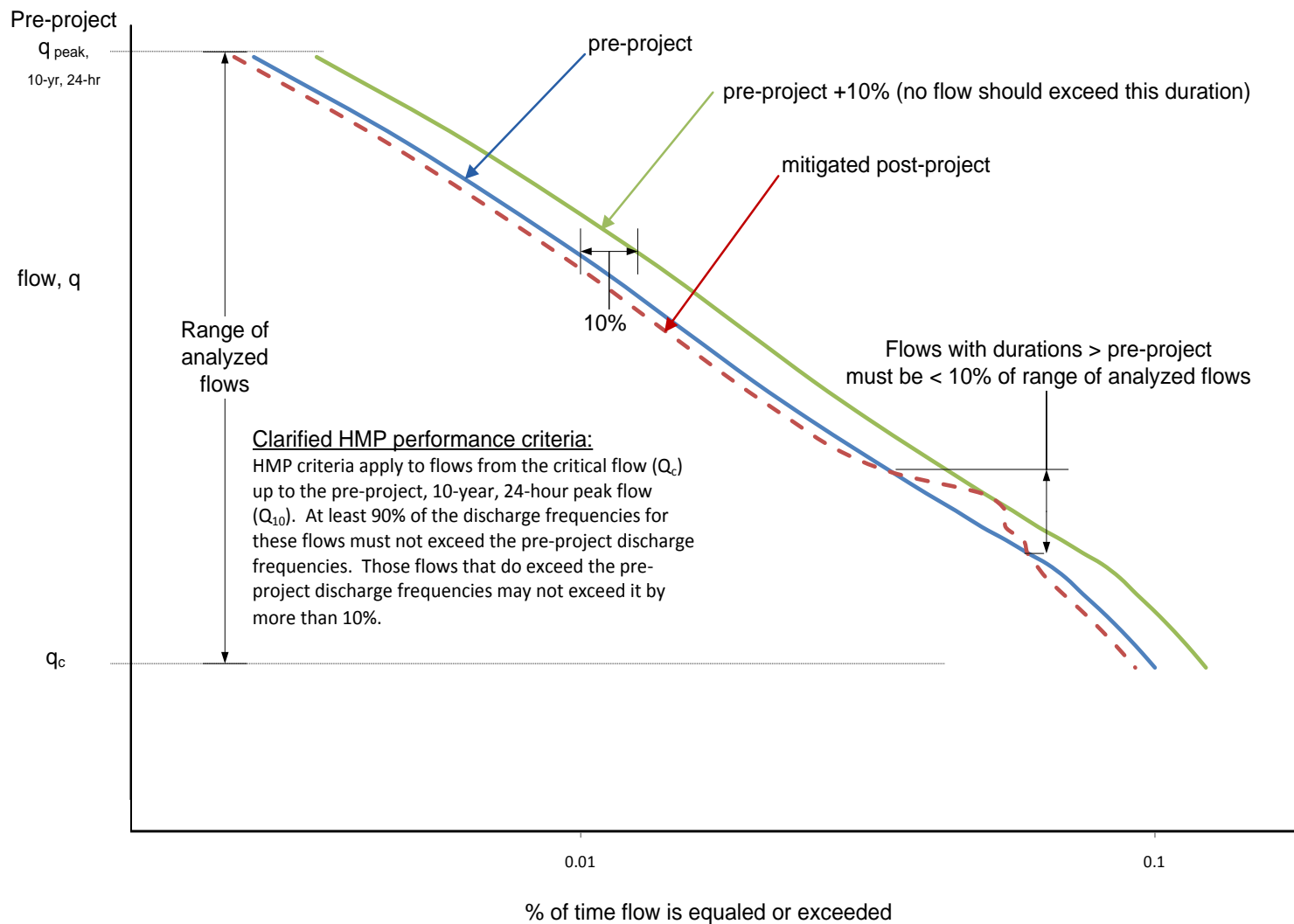

Projects that discharge to channels with high or very high susceptibility are required to design for a larger range of flows (0.25Q<sub>2</sub> – Q<sub>10</sub>) than projects that discharge to channels with low or medium susceptibility (0.45Q<sub>2</sub> – Q<sub>10</sub>). The larger range of flows will result in larger required hydromodification controls. The channel susceptibility is determined based on the susceptibility assessment tool in Chapter 4 of the SSQP HMP (<http://www.beriverfriendly.net/Newdevelopment/>). For project applicants that choose not to assess the susceptibility of the receiving waters, the lower flow rate (0.25 Q<sub>2</sub>) must be used.

### Alternative Design Approaches for Hydromodification Management

There may be some projects for which on-site hydromodification management is not feasible or desirable. In those cases, that applicant may choose to implement in-stream measures to address project hydromodification impacts (see Chapter 7 of the HMP). This alternative option requires continuous simulation modeling and field data collection. The results of the analysis will be subject to review by the permitting agencies and approval is not guaranteed. Additional information for in-stream hydromodification mitigation can be found in Chapter 8 of NRCS Part 654 Stream Restoration Design National Engineering Handbook. Other sources of information are available from the U.S. Army Corps of Engineers, the US EPA, and the California State Water Resources Control Board. Refer to the following:

<http://www.spk.usace.army.mil/Missions/Regulatory/Mitigation/>

<https://www.epa.gov/cwa-404/stream-assessment-and-mitigation-protocols-review-commonalities-and-differences>

## Low Impact Development Principles

The goal of low impact development measures is to mimic a site's predevelopment balance of runoff and infiltration by using design techniques that infiltrate, store, evaporate, and detain runoff close to its source. Low impact development controls are integrated into site design and can be distributed throughout the site in a series of small-scale (or micro-scale) measures. As explained in Chapter 1, this approach is one of the key elements in low impact development (LID) design.

For the purposes of this manual, LID is defined as follows: “Low impact development is a stormwater management strategy that emphasizes conservation and use of existing natural site features integrated with distributed, small-scale stormwater controls to more closely mimic natural hydrologic patterns in residential, commercial, and industrial settings.” (Puget Sound Action Team 2005)

---

*The goal of low impact development measures is to mimic a site's predevelopment balance of runoff and infiltration by using design techniques that infiltrate, filter, store, evaporate, and detain runoff close to its source.*

---

LID measures are typically integrated into site landscaping (including open space, yards, streetscapes, road medians, and parking lot and sidewalk planters) or into the design of paved and other impervious areas, such as the building roof. Small-scale runoff controls integrated into the project design and located close to the source of the water and

pollutants can help reduce the need to convey water and treat it in large, often more costly end-of-pipe facilities located at the bottom of drainage sheds. By reducing the total runoff volume, these measures can also help alleviate potential downstream habitat degradation and erosion problems.

Although LID measures can reduce the size/need for stormwater quality treatment and hydromodification facilities, other drainage and flood control design requirements for the project still apply, as specified by the local permitting agency. References for drainage and flood control requirements are listed in Appendix F. This chapter addresses the following basic low impact development strategies:

- Open Space Preservation
- Runoff Reduction
- Runoff Management

In order to allow flexible LID implementation that is both quantifiable and beneficial, a point system has been developed that permits a wide range of options that can be selected based upon the discretion of the practitioner given the unique characteristics of each project. Each priority new development or redevelopment project is required to earn a minimum of 100 points based upon the LID measures selected and implemented. The computational procedure for residential projects differs somewhat from commercial projects. A discussion of these methods as well as the method for tabulating points earned is also presented within this chapter. Examples of tabulating points for both residential and commercial sites can be found within Appendix A. Compliance with LID principles is required at all stages of approval, including master planning and final improvement or grading plans for individual projects.

### Open Space Preservation

Open space is defined as “non-impervious area within the project that is subtracted from the total project area to reduce the area used in sizing treatment BMPs”. Because of this benefit, open space is awarded LID credit points. The percentage of open space is translated directly into LID points on a 1:1 ratio (1 LID point for each 1% of open space in relation to the total project area).

For LID implementation, open space includes, but is not limited to, natural storage reservoirs, drainage corridors, buffer zones for natural water bodies, stream setbacks and buffers, and flood control detention basins.

There are two types of open space credits available, on-project and off-project. On-project open space is credited at a 1:1 ratio within the project area, and it also reduces the treatment area requirement. Off-project open space credit allows individual projects within a master planned community to also receive credit at a 1:1 ratio for the open space preserve (1 LID point for each 1% of open space in relation to the total master planning area), including parks, drainage corridors, and floodplains, etc. However, unlike the on-project open space, because this open space is not located within the project area it does not provide a reduction in the treatment area requirement. An example of tabulating open space LID points is presented within Appendix D.



## Runoff Reduction

This manual describes a range of methods to reduce runoff by replacing, strategically locating, and/or minimizing conventional impervious surfaces. The covered approaches are:

- Disconnection of Impervious Surfaces, such as Pavement Areas and Roof Drains
- Interceptor Trees

The LID point system uses the “Effective Area Managed” credit system for runoff reduction. Separate residential and commercial worksheets for determining “effective area managed” by runoff reduction measures can be found within Appendix D. For all projects, the LID point system assigns 1 point for every 1 percent of project area effectively managed (i.e. 1:1 ratio).

---

*Use of runoff reduction controls can reduce the amount of water requiring treatment on a site.*

---

### *Disconnection of Impervious Surfaces*

In conventional designs, runoff and associated pollutants from impervious surfaces (such as parking lots and roof tops) flow directly to a storm drain system. In other words, the impervious areas are “directly connected” to the storm drains. Impervious areas can be “disconnected” when the runoff from the area is redirected to flow over landscaping, into bioretention planters, or through pervious pavement. Criteria are provided in Appendix D to define how dimensional variation in impervious surface disconnection translates to “Effective Area Managed” credits.

This chapter introduces several measures that involve disconnecting impervious surfaces from the storm drain system:

- Disconnected Pavement
- Disconnected Roof Drains - including disconnection through infiltration systems

Refer to Disconnected Pavement and Disconnected Roof Drain BMP Fact Sheets for additional information.

### *Interceptor Trees*

Trees intercept stormwater and can retain a significant amount of the captured water on their leaves and branches, allowing for evaporation and dissipation of the energy of runoff. Their root structures absorb and uptake runoff and associated pollutants. The shade provided by trees keeps the ground under the trees cooler, thereby reducing the amount of heat gained in runoff as it flows over the surface and into the storm drain. In turn, this helps keep stream temperatures cool and healthy for fish and other aquatic life.

Developers and designers who use trees as part of an integrated post-construction stormwater quality plan can receive interceptor tree credits as described in Appendix D. Appendix D also describes how interceptor tree credits are translated to “Effective Area Managed” credits for runoff reduction as a function of tree type (i.e. evergreen, deciduous, etc.).

Refer to the Interceptor Trees BMP Fact Sheet for additional information.

## Runoff Management

This manual describes a range of methods to manage runoff by replacing, strategically locating, and/or minimizing conventional impervious surfaces. The covered approaches are:

- Porous Pavement
- Alternative Driveways
- Green Roof
- Capture and Re-Use
- Compost-Amended Soil

The LID point system also uses the “Effective Area Managed” credit system for runoff management. Separate residential and commercial worksheets for determining “effective area managed” by runoff management measures can be found within Appendix D. For all projects, the LID point system assigns 2 points for every 1 percent of project runoff from area effectively managed (i.e. 2:1 ratio).

SAHM can also be used to demonstrate LID compliance through volume reduction. For all projects, the LID point system assigns 2 points for every 1 percent of volume reduction (i.e. 2:1 ratio). Volume reduction is calculated as follows:

$$\% \text{ Volume Reduction} = \frac{(\text{Un-Mitigated Post Development Volume} - \text{Mitigated Post Development Volume})}{(\text{Un-Mitigated Post Development Volume} - \text{Pre Development Volume})} \times 100$$

### *Porous Pavement*

Traditional asphalt and concrete pavement can be substituted with one of several different types of porous pavements, such as pervious concrete and pavers. The degree of permeability varies by type of material (for example, reinforced grass pavement is more pervious than cobblestone pavers), and the appropriate type to use depends on anticipated traffic loads and uses. There are various examples of pervious concrete, and many examples of pavers installed throughout the Sacramento area. Refer to the Porous Pavement BMP Fact Sheet for additional information.



*Porous Pavement at  
Fair Oaks Promenade,  
City of Folsom*



*Porous Pavement at  
Elk Grove-Rain Garden Plaza*

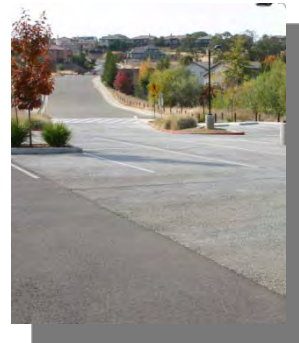

*Porous Pavement at  
Nisenan Community Park,  
City of Folsom*

### *Alternative Driveway*

Alternative driveways are one design application which involves replacing all or a portion of a standard impervious driveway with pervious materials such as grass or pavers. Check with the local permitting agency for any restrictions associated with the use of porous pavements or alternative driveway designs. Refer to the Alternative Driveway BMP Fact Sheet for additional information.

### *Green Roof*

Instead of using conventional roofs, which generate runoff during a rain storm, consider installing a “green roof”, also known as an “ecorooft.” The roof functions like a sponge, using several inches of soil and a top layer of vegetation to capture and slow rainwater as it flows from the rooftop to the ground. The concept has been popular in Europe for centuries, has become more common in the Pacific Northwest and Midwest (e.g., Chicago), and is gaining popularity in California. Various green roof installations have been completed since the late 1990s in the San Francisco Bay Area and more recently in southern California. See the references at the end of this chapter for more information. Also refer to the Green Roof BMP Fact Sheet for additional information.

### *Capture and Re-Use*

Excess stormwater volume resulting from project impervious surfaces can be captured and re-used on site to mitigate impacts to receiving waters. The most typical application of the capture and re-use approach is store excess stormwater as a supplement for irrigation supply, although additional re-use options may be available for commercial development. Residential development can incorporate measures such as rain barrels, cisterns, or ponds to effectively capture and re-use stormwater runoff from roof areas.

### *Compost-Amended Soil*

The compost-amended soil BMP is an option in the BMP toolbox that has a smaller footprint than impervious surface disconnection. This BMP option is intended to be a less complex alternative compared to bioretention and engineered infiltration BMPs. Compost-amended soil is also ideal as a design feature in landscape and open space areas. The volume of water to be infiltrated is assumed to be captured within pore spaces of a simple, depressed bed of mulch and compost-amended soil that overlies the native soil (with no underdrain). The mulch and amended soil provide short-term storage for the water until it can infiltrate the native underlying soil. Refer to the Compost-Amended Soil BMP Fact Sheet for additional information.

## Selecting Low Impact Development Measures for Your Project

Refer to Table 3-3 to determine which LID control measures may be used in your project. Work with your civil/geotechnical engineer and planner to study the infiltration capacity of the soils and the future use of the site when making this determination. The local permitting agency may require permeability tests, depending on the type of control measure and site conditions. For pervious pavement, identify parking areas, walkways and patios that will not experience high traffic loadings. Involve your landscape architect in the initial site layout to locate and slope paved areas toward

vegetated areas whenever possible. Once you've selected the measures most appropriate for the site, refer to the LID credit worksheets (Appendix D) to prepare the site design.

### Low Impact Development Points Worksheets

Appendix D includes worksheets for calculating LID points for residential and commercial priority new development and redevelopment projects and background information documenting the process used to derive the score. Use the worksheets to determine to what extent you can reduce project runoff by incorporating one or more of the LID control measures described in this chapter. Use the worksheets also to determine the remaining required treatment water quality volume or flow (if any) adjusted for low impact development use, and then use Chapter 5, **Hydromodification Management, Low Impact Development, and Treatment Control Measures**, and Appendix E to guide you through the process of selecting and sizing your treatment measures.

### Treatment Control Principles

The stormwater quality treatment control measures profiled in this chapter are the more common ones being implemented throughout the state and the rest of the country. Studies have shown these measures to be effective if properly installed and maintained. Alternative technologies that provide equivalent treatment may be proposed and will be considered by the permitting agencies, but may result in additional time for agency review and approval unless coordinated well in advance with the appropriate agency staff.

Stormwater quality treatment control measures are engineered technologies designed to remove pollutants from site runoff. They can have a higher cost and require more space than the LID measures discussed elsewhere in this chapter. All development and redevelopment projects meeting the size thresholds on Table 3-3 require treatment control measures, but the required treatment volume or flow can be reduced (potentially to zero) through the use of LID measures. The treatment control methods suitable for a given project depend on a number of factors including: type of pollutants to remove, amount of stormwater runoff to be treated, site conditions, and state general industrial NPDES permit requirements, when applicable. Land requirements, and costs to design, construct and maintain treatment control measures vary by measure and locale.

Unlike flood control measures that are designed to handle peak flows from large storm events, stormwater quality treatment control measures are designed to treat the more frequent, lower flow storm events. Small frequent storm events (0.5 inches of rain and less) on the average represent over 80% of the total average annual rainfall for the Sacramento area. The water quality flow (WQF) and water quality volume (WQV) are targeted for treatment in order to reduce pollutants to the “maximum extent practicable” standard.

## Selecting Treatment Control Measures

If stormwater quality treatment control measures are required for your project, the answers to the following questions will help you determine the appropriate control measure(s) for your unique conditions:

- What are **pollutants of concern** for the future land use of the development?  
See Table 3-1 in Chapter 3, which correlates project types with likely pollutants of concern. When you have identified the pollutants, you can use the pollutant removal effectiveness information on the fact sheets at the end of this chapter to find control measures that would be most appropriate for treating those pollutants.
- What **amount of stormwater runoff** will need to be treated?  
The amount of stormwater runoff that needs to be treated for a site is defined by the local permitting agencies as the water quality volume (WQV) or water quality flow (WQF), described later in this chapter. In the Sacramento region, treating this amount of runoff is presumed to remove pollutants in urban runoff to the maximum extent practicable. Using LID measures will decrease the amount of runoff needing to be treated, which in turn will likely reduce costs and space requirements for the treatment control measures.

Appendix D will lead you through the process of credits for “effective area managed” and then determining the remaining water quality volume or flow remaining to be treated.

- **How much space is available** on the project site for a stormwater quality treatment facility?  
Refer to the fact sheets at the end of this chapter to determine the space requirements for the various types of stormwater quality control measures. Consider that vegetated facilities can typically be integrated into the landscaping already required by the permitting agency for the site. Also, although underground facilities do not take up as much space, they can be more costly to construct and maintain.
- What are the **site conditions and associated limitations** on use of stormwater quality treatment control measures for this property?  
As described in the fact sheets at the end of this chapter, the selection and design of stormwater quality control measures is largely dependent on soils, topography/slope and other natural site features.
- What **level of maintenance** will the property owner be capable and willing to conduct as long as he/she owns the property?  
Consider the short and long-term maintenance needs of the treatment control measures (as described on the fact sheets at the end of this chapter) and whether or not the property owner can agree to those requirements. The permitting agencies in the Sacramento Region require that the property owner sign a maintenance agreement or obtain a permit to ensure long-term maintenance. Such maintenance agreements require reconstruction or replacement of the feature when it fails to function properly. For informational purposes, projected lifespan information is provided for the various control measures in Appendix B.

## Designing Treatment Control Measures

The treatment control measures presented in this manual are sized and configured using either a volume-based or flow-based design approach, as explained in more detail in Appendix E:

### Volume-Based Design (WQV)

Treatment control measures that depend on storage and gravitational settling for pollutant removal (e.g. detention basins, vaults) are designed for the water quality volume. Volume-based design criteria call for the capture and infiltration or treatment the runoff from the project site from the 85th percentile runoff event.

### Flow-Based Design (WQF)

Flow-through treatment control measures that do not require long detention times for pollutant removal (e.g. vegetated swales) are designed for the water quality flow. Flow-based design criteria call for the capture and treatment of the flow produced by rain events of a specified magnitude, usually the 85th percentile hourly rainfall intensity multiplied by a factor of 2. This equate to an intensity of 0.20 inches/hour for projects in the City of Folsom and 0.18 inches/hour for projects located in other cities in Sacramento County and unincorporated Sacramento County.

Appendix E includes instructions for calculating the expected water quality volume (WQV) or water quality flow (WQF) for your project. The procedure requires you to determine the amount of impervious surfaces that will contribute runoff to the treatment control measures. In addition, site run-on that is not diverted around the site and combines with other runoff will need to be treated.

## Proprietary Treatment Control Measures

Proprietary stormwater quality treatment measures are manufactured devices intended to capture and treat post-construction site runoff to remove pollutants. The permitting agencies in Sacramento County allow certain proprietary devices for treatment of runoff, under certain conditions, as described below.

**Agencies in Sacramento:** Since the late 1990's, the Sacramento Stormwater Quality Partnership has been conducting a study to investigate and verify the field performance of proprietary stormwater quality devices. In November 1999, the Partnership published a report that describes the protocol that must be followed in order for a particular device to be accepted for use in the Sacramento area. The protocol is based on a comparison of the performance of the proprietary device to that of widely- accepted public domain measures, such as vegetated swales. Manufacturers are invited to submit data that can be reviewed for conformance with the protocol. In addition to devices accepted using the Sacramento area protocol, the Partnership will consider technologies with the Washington State Department of Ecology's General Use Level Designation for Basic (TSS) Treatment on a case by case basis.

For an updated list of accepted devices and more details on the Sacramento proprietary study, see [www.beriverfriendly.net](http://www.beriverfriendly.net) (new development). In select cases, the local permitting agency may allow the use of other proprietary treatment measures as a "pilot study." In such cases, the property owner and/or manufacturer will be required to fund and complete a monitoring study to verify the device's performance. Since approval is not guaranteed, site designers proposing to use an alternative technique should coordinate with the permitting agency early in the site design process.

Site designers proposing to use accepted proprietary device(s) on their project need to include the following items in the submittal and on the (to scale) improvement plans:

- Plan view of device & appurtenances on the civil site plans
- Section view of device & appurtenances in reference to other utilities
- Detail drawings of device & appurtenances
- Specifications and installation notes.

## Operation and Maintenance

The property owner is ultimately responsible for the operation, maintenance, and long-term continued performance of the hydromodification management, low impact development, and treatment control measure(s). Failure to properly operate and maintain the measures could result in no mitigation of stormwater impacts. Inadequate stormwater management is a violation of the local permitting agencies' municipal codes, as well as state and federal water quality regulations.

For projects using these control measures, verification of long-term maintenance provisions is required. This is mandated by the agencies' State-issued stormwater permits. The local permitting agencies in the Sacramento area require execution of a maintenance agreement, covenant or permit with the property owner. Typically, maintenance agreements and covenants are recorded with the deed for the property and follow property ownership. Such maintenance agreements require reconstruction or replacement of the feature when it fails to function properly. For informational purposes, Appendix B presents projected lifespan information for the various control measures.

Check with the local permitting agency about the maintenance submittal requirements and timing for execution of the agreement. See Appendix B for additional information and a sample maintenance agreement.

## References

- Adams, M.C., *Porous Asphalt pavement with recharge beds: 20 years & still working*, Stormwater, May/June 2003.  
[http://www.stormh2o.com/SW/Articles/Porous\\_Aspphalt\\_Pavement\\_With\\_Recharge\\_Beds\\_20\\_Year\\_228.aspx](http://www.stormh2o.com/SW/Articles/Porous_Aspphalt_Pavement_With_Recharge_Beds_20_Year_228.aspx)
- Atlanta Regional Commission, *Georgia Stormwater Management Manual, Volume 2 Technical Handbook*, August 2001. [www.georgiastormwater.com](http://www.georgiastormwater.com)
- Bay Area Stormwater Management Agencies Association, *Start at the Source - Design Guidance Manual for Stormwater Quality Protection*, 1999.  
<http://www.cccleanwater.org/publications/>
- California Stormwater Quality Association, *California Storm Water Best Management Practice Handbook for New Development and Redevelopment*, January 2003 (revised September 2004).  
[www.cabmphandbooks.com](http://www.cabmphandbooks.com)
- Center for Watershed Protection, Ellicott City, Maryland (Cappiella, K.), *Urban Watershed Forestry Manual*. Prepared for USDA Forest Service, Northeastern Area State and Private Forestry, July 2005. <http://www.na.fs.fed.us/watershed/publications.shtm>
- Center for Watershed Protection, Ellicott City, Maryland (Shueler T., Swann C., Wright T, and S. Sprinkle), *Urban Subwatershed Restoration Manual No 8: Pollution Source Control Practices. Version 1.0*, July 2004.
- Center for Watershed Protection, New York State Department of Environmental Conservation, Albany, NY, *New York State Stormwater Management Design Manual*, October 2001 (Revised August 2010). <http://www.dec.ny.gov/chemical/29072.html>
- City of Davis, *City of Davis Community Forest Management Plan*, September 11, 2002.  
<http://www.cityofdavis.org/pcs/trees/cfmp.cfm>
- City of Long Beach, Development Services, *Small Scale Residential LID BMP Measures: Dry Well Fact Sheet*, <http://www.lbds.info/civica/filebank/blobload.asp?BlobID=3849>.
- City of Pasadena, *California Code of Regulations, Hollywood Driveway*.  
<http://www.ci.pasadena.ca.us/zoning/P-8.html> accessed March 6, 2006.
- City of Portland, Oregon, Bureau of Environmental Services, *Maintaining your Stormwater Management Facility*, 2002. <https://www.portlandoregon.gov/bes/31892>
- City of Portland, Oregon, Bureau of Environmental Services, *Stormwater Management Manual*, 2008. <https://www.portlandoregon.gov/bes/31892>
- City of Portland, Oregon, *Sustainable Infrastructure Alternative Paving Materials Subcommittee Report*, October 3, 2003.  
<http://www.portlandonline.com/shared/cfm/image.cfm?id=53556>
- City of San Jose, California, City Council Policy, *Post-Construction Urban Runoff Management*, February 3, 1998 (Revised October 4, 2011).  
[http://www3.sanjoseca.gov/clerk/cp\\_manual/CPM\\_6\\_29.pdf](http://www3.sanjoseca.gov/clerk/cp_manual/CPM_6_29.pdf)
- Clear Creek Solutions, Inc., *Sacramento Area Hydrology Model (SAHM) Guidance Document*, March 2013. <http://www.beriverfriendly.net/docs/files/File/NewDev/SAHM-Guidance-Mar2013.pdf>



- Colorado State University Extension, *Choosing a Soil Amendment*, Fact Sheet No. 7.235, June 2000 (revised February 2013). <http://www.ext.colostate.edu/pubs/garden/07235.pdf>
- Colorado State University Extension, *Soil Amendments*, CMG GardenNotes #241. <http://www.ext.colostate.edu/mg/gardennotes/241.html>.
- Contra Costa Clean Water Program, *Stormwater C.3 Guidebook*, 6th Edition, February 2012. [www.cccleanwater.org/stormwater-c-3-guidebook](http://www.cccleanwater.org/stormwater-c-3-guidebook)
- Federal Highway Administration, *Environmental Review Toolkit: Fact Sheet – Detention Tanks and Vaults*, <http://environment.fhwa.dot.gov/ecosystems/ultraurb/3fs6.asp>, accessed 6/3/13.
- LakeSuperiorStreams.org, *Site Design Toolkit: Underground Storage*, <http://www.lakesuperiorstreams.org/stormwater/toolkit/underground.html>, accessed 6/3/13.
- Low Impact Development Center, *Fairfax County – LID BMP Fact Sheet – Soil Amendments*, February 28, 2005. [http://www.lowimpactdevelopment.org/ffxcty/5-1\\_soilamendments\\_draft.pdf](http://www.lowimpactdevelopment.org/ffxcty/5-1_soilamendments_draft.pdf)
- Natural Resources Conservation Service, *NRCS Part 654 Stream Restoration Design National Engineering Handbook*, May 2008. <http://directives.sc.egov.usda.gov/viewerFS.aspx?hid=21433>
- New Hampshire Department of Environmental Services, *New Hampshire Homeowner’s Guide to Stormwater Management Do-It-Yourself Stormwater Solutions: Dry Well*, March 2011 (revised February 24, 2012), <http://des.nh.gov/organization/divisions/water/stormwater/stormwater-mgmt-homeowners.htm>.
- Office of Water Protection, *Low Impact Development Standards Development, Stormwater Quality Design Manual Update and BMP Sizing Tool Enhancement – Task 1: Develop Low Impact Development (LID) Standards for New Development and Redevelopment Projects and Associated Work*, June 23, 2012.
- Paris N. and M. Chusid, *Coloring Pervious Pavement... because protecting the environment should be beautiful*, 2006. [www.ConcreteDecor.net](http://www.ConcreteDecor.net) Dec/Jan 2006.
- Portland Water District, *Maine, Conservation Practices for Homeowners: Dry Wells*, May 2006, [http://www.pwd.org/pdf/water\\_resources/conservation%20fact%20sheets/dry\\_wells.pdf](http://www.pwd.org/pdf/water_resources/conservation%20fact%20sheets/dry_wells.pdf).
- Sacramento Stormwater Quality Partnership, *Hydromodification Management Plan (HMP)*, July 29, 2011 (Revised February 14, 2013). <http://www.sacstormwater.org/ConstructionandNewDevelopment/NewDevelopment/HMP/HMPReport.pdf>
- San Francisco Public Utilities Commission, *San Francisco Stormwater Design Guidelines: BMP Fact Sheets*, November 2009.
- SMRC, The Stormwater Manager’s Resource Center. *Fact Sheets*. [http://www.stormwatercenter.net/Assorted%20Fact%20Sheets/Tool6\\_Stormwater\\_Practices/Infiltration%20Practice/Porous%20Pavement.htm](http://www.stormwatercenter.net/Assorted%20Fact%20Sheets/Tool6_Stormwater_Practices/Infiltration%20Practice/Porous%20Pavement.htm) accessed June 14, 2006.
- SMRC, The Stormwater Manager’s Resource Center. *Manual Builder*. [http://www.stormwatercenter.net/Manual\\_Builder/Credits/SITE/reforestation.htm](http://www.stormwatercenter.net/Manual_Builder/Credits/SITE/reforestation.htm)
- SMRC, The Stormwater Manager’s Resource Center. *Manual Builder*. [http://www.stormwatercenter.net/Manual\\_Builder/Credits/SITE/rooftop.htm](http://www.stormwatercenter.net/Manual_Builder/Credits/SITE/rooftop.htm)

- SvR Design Company, *High Point Community Site Drainage Technical Standards*, Seattle, WA, May 2004 (Revised December 2006). [http://www.svrdesign.com/docs/High-Point-Technical-Drainage-Standards\\_LID\\_GSI\\_green-stormwater-infrastructure\\_web.pdf](http://www.svrdesign.com/docs/High-Point-Technical-Drainage-Standards_LID_GSI_green-stormwater-infrastructure_web.pdf)
- *Truckee Meadows Regional Storm Water Quality Management Program: Draft Low Impact Development Handbook*, August 2005.
- United States Environmental Protection Agency, *National Menu of Best Management Practices for Storm Water Phase II*, 2002. <http://cfpub.epa.gov/npdes/stormwater/menuofbmps/index.cfm>
- University of Connecticut, *Nonpoint Education for Municipal Officials*. Accessed May 26, 2006. <http://nemo.uconn.edu>
- Urban Drainage and Flood Control District, Denver, Colorado, *Urban Storm Drainage Criteria Manual Volume 3 – Best Management Practices*, September 1999 (Rev. January 2013). [www.udfcd.org/downloads/down\\_critmanual\\_volIII.htm](http://www.udfcd.org/downloads/down_critmanual_volIII.htm)
- U.S. Environmental Protection Agency, *Stormwater Menu of BMPs: In-Line Storage*, <http://cfpub.epa.gov/npdes/stormwater/menuofbmps/>, access 6/3/13.
- Virginia Cooperative Extension, *Best Management Practice Fact Sheet 4: Soil Restoration*, Publication 426-123. [http://pubs.ext.vt.edu/BSE/BSE-24/BSE-24\\_pdf.pdf](http://pubs.ext.vt.edu/BSE/BSE-24/BSE-24_pdf.pdf)
- Virginia Department of Conservation and Recreation, *Virginia Stormwater Management Program Handbook*, 1999. [http://www.dcr.virginia.gov/stormwater\\_management/stormwat.shtml#vswmhnbk](http://www.dcr.virginia.gov/stormwater_management/stormwat.shtml#vswmhnbk)
- Xiao Q., and E.G. McPherson, *Rainfall interception by Santa Monica's municipal urban forest*, *Urban Ecosystems*, 2003.
- Xiao, Q., E.G. McPherson, S.L. Ustin and M.E. Grismer, *A new approach to modeling tree rainfall interception*, *Journal of Geophysical Research* 105(D23) :29,173-29,188. 2000. [http://www.fs.fed.us/psw/programs/uesd/uep/products/4/cufr\\_88.pdf](http://www.fs.fed.us/psw/programs/uesd/uep/products/4/cufr_88.pdf)
- Xiao, Q., E.G. McPherson, S.L. Ustin, M.E. Grismer, and J.R. Simpson, *Winter rainfall interception by two mature open grown trees in Davis, CA*, *Hydrological Processes*. 14(4) :763-784. 2000. [http://www.itreetools.org/streets/resources/Winter\\_rainfall\\_interception\\_Xiao.pdf](http://www.itreetools.org/streets/resources/Winter_rainfall_interception_Xiao.pdf)
- Xiao, Q., *Rainfall interception by urban forests*. Davis, CA: University of California. Ph.D. Dissertation, 1998.
- Urban Drainage and Flood Control District, Denver, Colorado, *Urban Storm Drainage Criteria Manual Volume 3 – Best Management Practices*, September 1999 (Rev. January 2013). [www.udfcd.org/downloads/down\\_critmanual\\_volIII.htm](http://www.udfcd.org/downloads/down_critmanual_volIII.htm)
- Ventura Countywide Stormwater Quality Management Program, *Land Development Guidelines*, August 2001.

## Fact Sheets

This chapter includes fact sheets for all of the hydromodification management, low impact development, and treatment control measures listed in Table 3-3. Each fact sheet describes the purpose of the control measure, applicability, design requirements, and any operation and maintenance issues that may affect its design.

THIS PAGE INTENTIONALLY LEFT BLANK

# Alternative Driveways

---

## Description

Alternative driveways are designed to reduce the volume and rate of runoff and increase localized infiltration. These driveways exhibit one or more of these features: permeable surfaces, drain to landscaping, provide access to more than one house, and/or limit concrete use to narrow driving strips. It is recommended that you read the Porous Pavement and Disconnected Pavement fact sheets before using this one, since this technique employs principles from those fact sheets.



*Photo source: City of Folsom*

## Siting Considerations

- Land use: Single-family residential development and redevelopment.
- Driveway slope: 10% maximum.
- Soils: Appropriate for all soil types but porous pavement requires an underdrain for soil types C and D.

## Vector Considerations

- Potential for mosquitoes in vegetated features of alternative driveways due to standing water (at or near the surface) will be greatly reduced or eliminated if the driveway is properly designed, constructed, and operated to maintain its infiltration capacity.

## Advantages

- Replaces regular pavement, so does not require additional land on the site.
- Can reduce size of downstream stormwater quality treatment measures by reducing the volume required to treat.
- Sometimes more attractive than traditional pavement.
- Potential LEED Credits
  - Credit 6.1 – Stormwater Design – Quantity Control

## Limitations

- If driveway includes a public right-of-way or utility easement, contact local permitting agency to determine if alternative driveway design is acceptable and if so, any special requirements.
- See Siting Considerations.

## Maintenance Recommendations

- Driveways with disconnected pavement require no additional maintenance over traditional driveways, but accumulations of sediment adjacent to driveway need to be removed periodically to keep surface water flowing evenly into the adjacent porous area.
- Refer to Porous Pavement fact sheet for maintenance requirements related to pavers, modular block and other porous materials.

## How Do Alternative Driveways Work?

Driveways can comprise a significant portion of the total transportation network in a conventional suburban residential development. Alternative driveways reduce a development’s total directly connected impervious surface by using permeable materials, reducing the amount of pavement, paving area and/or by draining to landscaped areas. This, in turn, reduces the runoff and may provide incidental pollutant removal. Alternative driveway designs are easily adopted into most residential construction projects, can improve the aesthetics, and, if incorporated early in project design, may reduce the size and associated cost of treatment controls.

## Planning and Siting Considerations

- Consult a geotechnical engineer as to the suitability of each type of Alternative Driveway for specific load requirements.
- For Alternative Driveways using porous pavement, see planning and siting considerations on the Porous Pavement Fact Sheet elsewhere in this chapter
- Specific design considerations apply to each type of Alternative Driveway (see variations discussed below).

## Variations

Four types of Alternative Driveways are discussed in this fact sheet: 1) pervious driveway, 2) “Hollywood” driveway, 3) disconnected driveway, and 4) shared driveway. Alternative designs may be acceptable on a case-by-case basis; check with the local permitting agency for verification before proceeding with design.

### Pervious Driveway

Pervious driveways allow water to pass through the driveway surface via void spaces in the material and/or between units. Various types of pavement may be used to make the driveway surface permeable: pervious concrete or asphalt, modular block, cobblestone block or porous gravel (see Porous Pavement Fact Sheet elsewhere in this chapter for details). Design Criteria: See Table AD-1 for design criteria. Also, refer to the Porous Pavement fact Sheet.



*Pervious Driveway.  
Photo: Carrera Construction*

## “Hollywood” Driveway

A Hollywood Driveway, where only the wheel tracks are paved with concrete, is a viable, inexpensive design if the driveway is straight. The center strip can be left open to be planted with grass or groundcover, or filled with a permeable material such as gravel, modular block pavement, or pervious pavement if water conservation/ irrigation is a concern.

*Design Criteria:* See Table AD-1 for design criteria.

*Other names:* ribbon driveway, paving-under-wheels driveway



*“Hollywood” Driveway in Natomas area, Sacramento. Photo: ECORP Consulting*



*“Hollywood” Driveway in Southland Park area, Sacramento. Photo: ECORP Consulting*

## Disconnected Driveway

Conventional driveways are considered “directly connected” to the storm drain system because stormwater runoff from the driveway enters the storm drain system directly. Driveways disconnected from the storm drain system reduce runoff and provide incidental pollutant removal by passing runoff over an adjacent vegetated or otherwise porous surface that intercepts, infiltrates and filters the runoff. There are various design approaches: 1) slope the driveway to drain onto adjacent turf or groundcover, 2) install a slotted drain near the lower third of the driveway and discharge the drain to a landscaped area (if this is not considered a safety/tripping hazard), and 3) install grooves in the driveway pavement to help direct flow to the vegetated area. Some agencies may also allow an under sidewalk drain which connects the depressed landscape area adjacent to the driveway with the gutter/storm drain.

*Design Criteria:* See Table AD-1 for design criteria.

## Shared Driveway

Driveways can be configured to provide access to two or more garages. Consult the local permitting agency to determine if this practice will be allowed for your project.

## Design Criteria

Design criteria for alternative driveways are listed in Table AD-1.

*Table AD-1. Alternative Driveways Design Criteria*

Also see Appendix D for information on calculating runoff reduction credits.

Variation/ Design Parameter	Requirement
<i>Pervious Driveway</i>	
General	<ul style="list-style-type: none"> <li>See Porous Pavement Fact Sheet for specifications.</li> <li>Surface sloped to provide positive drainage away from building foundations.</li> </ul>
Subgrade drain	<ul style="list-style-type: none"> <li>Required in C and D soils. Use a gravel trench or perforated pipe embedded in a 8-12-inch layer of crushed rock. Connect to another LID element or the storm drain system (not sanitary sewer).</li> </ul>
<i>Hollywood Driveway</i>	
General	<ul style="list-style-type: none"> <li>Tracks 2.5 to 3.5 feet wide, separated by a porous center strip at least three feet wide.</li> <li>Slope driveway toward center strip to promote drainage or install grooves to help direct flow into porous strip.</li> <li>Porous center strip groundcover, grass, or drain rock.</li> </ul>
Porous center strip	<ul style="list-style-type: none"> <li>Groundcover, grass, drain rock, or porous pavement.</li> </ul>
Irrigation	<ul style="list-style-type: none"> <li>Consider irrigation for center strip vegetation.</li> </ul>
<i>Disconnected Driveway</i>	
General	<ul style="list-style-type: none"> <li>Design the driveway cross slope greater than the longitudinal slope so that runoff is directed across landscape.</li> <li>Size the adjacent landscape area to accommodate flow from the driveway. Water from driveway surface should flow an average of 8 feet over landscaping prior to reaching the right of way.</li> <li>If a slotted drain is used, install it perpendicular to the flow path to direct flow into vegetation, and provide removable grates for cleaning.</li> <li>If runoff flows across sidewalk, it must sheet flow and spread at least two feet wide to avoid concentrated flows.</li> </ul>
Edge of driveway	<ul style="list-style-type: none"> <li>Must be approximately 3 inches above the vegetated area.</li> </ul>
<i>Shared Driveway</i>	
General	<ul style="list-style-type: none"> <li>Configurations vary, consult local permitting agency.</li> </ul>

## Construction Considerations

- Disconnected driveway: Properly slope the grade of the driveway and adjacent porous area to allow for even sheet flow over the porous material. Level of turf should be below top of pavement.



- Porous Pavement: See Porous Pavement BMP Fact Sheet Construction Considerations, elsewhere in this chapter.

## Long-term Maintenance Recommendations

Refer to the inspection and maintenance recommendations in the Porous Pavement Fact Sheet.

## Resources for More Information

- California Nevada Cement Promotion Council (CNCPC), [www.cnccp.org](http://www.cnccp.org)
- National Ready Mixed Concrete Association (NRMCA), [www.nrmca.org](http://www.nrmca.org)
- Pacific Southwest Concrete Alliance, [www.concreteresources.net](http://www.concreteresources.net)
- Asphalt Pavement Association, [www.apaca.org](http://www.apaca.org)
- National Precast Concrete Association, [www.precast.org](http://www.precast.org)
- Portland Cement Association, [www.portcement.org](http://www.portcement.org)
- National Asphalt Pavement Association, [www.hotmix.org](http://www.hotmix.org)
- Asphalt Emulsion Manufacturers Association, [www.aema.org](http://www.aema.org)
- Western States Chapter of the American Concrete Pavement Association, [www.wscacpa.com](http://www.wscacpa.com)
- Association of Asphalt Paving Technologists, [www.asphalttechnology.org](http://www.asphalttechnology.org)
- American Concrete Paving Association, [www.pavement.com](http://www.pavement.com)

## References

- Adams, M.C., *Porous Asphalt pavement with recharge beds: 20 years & still working*. Stormwater. May/June 2003.
- Bay Area Stormwater Management Agencies Association, *Start at the Source - Design Guidance Manual for Stormwater Quality Protection*, 1999.
- California Stormwater Quality Association, *California Stormwater Best Management Handbook: New Development and Redevelopment*, 2003.
- City of Pasadena, *California Code of Regulations. Hollywood Driveway*, accessed March 6, 2006, [www.ci.pasadena.ca.us/zoning/P-8.html](http://www.ci.pasadena.ca.us/zoning/P-8.html)
- City of Portland, *City of Portland Stormwater Management Manual*. Revision 3, September 1, 2004.
- City of Portland, *Sustainable Infrastructure Alternative Paving Materials Subcommittee Report*, October 3, 2003.
- Paris N. and M. Chusid, *Coloring Pervious Pavement... because protecting the environment should be beautiful*, Dec/Jan 2006. [www.ConcreteDecor.net](http://www.ConcreteDecor.net)

## Alternative Driveways

- SMRC, *The Stormwater Manager's Resource Center. Fact Sheets*. Accessed June 14, 2006. [www.stormwatercenter.net/Assorted%20Fact%20Sheets/Tool6\\_Stormwater\\_Practices/Infiltration%20Practice/Porous%20Pavement.htm](http://www.stormwatercenter.net/Assorted%20Fact%20Sheets/Tool6_Stormwater_Practices/Infiltration%20Practice/Porous%20Pavement.htm)
- *Truckee Meadows Regional Storm Water Quality Management Program: Draft Low Impact Development Handbook*, August 2005.
- United States Environmental Protection Agency, *National Menu of Best Management Practices for Storm Water Phase II*, 2002. <http://cfpub.epa.gov/npdes/stormwater/menuofbmps/index.cfm>
- University of Connecticut, *Nonpoint Education for Municipal Officials*, Accessed May 26, 2006. <http://nemo.uconn.edu>
- Urban Drainage and Flood Control District, Denver, CO, *Urban Storm Drainage Criteria Manual Volume 3 – Best Management Practices*, September, 1999 (Rev. June, 2002).
- Virginia Department of Conservation and Recreation, *Virginia Stormwater Management Program Handbook*, 1999.

# Bioretention Planter

## Description

A bioretention planter is a low-lying vegetated planter that receives runoff from roof drains or adjoining paved areas. A shallow surcharge zone above the vegetated surface temporarily stores stormwater (the water quality volume, WQV). The accumulated runoff gradually infiltrates into an underlying sand/peat bed and then into a gravel layer. If the planter is a flowthrough bioretention planter, it has an impermeable bottom liner and an underdrain pipe to collect the treated water and discharge it to the municipal storm drain. Planters without an impermeable bottom liner (infiltration planters) may also require an underdrain when the underlying soils are less permeable than the planter's sand/peat layer.

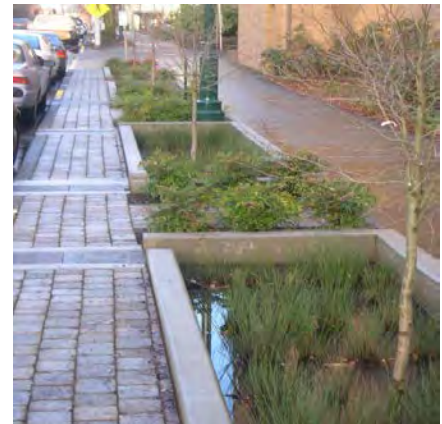

Photo Credit: City of Portland

## Siting Considerations

- Contributing Drainage area: Typically  $\leq 1$  acre.
- Depth to Groundwater:  $> 10$  ft from planter soil surface (only applies to infiltration planter without underdrain).
- Slope: Relatively flat.
- Planters can be used with any soil type, although depending on the recommendations of the project geotechnical engineer, a liner and/or underdrain may be needed.
- Setback: Flow-through planter is required if within 10 ft. of building foundation unless otherwise specified by local permitting agency.

## Vector Considerations

- Potential for mosquitoes due to standing water will be greatly reduced or eliminated if the planter is properly designed, constructed, and maintained.

## Advantages

- Relatively inexpensive when integrated into site landscaping.
- Suitable for parking lots and sites with limited space.

### Pollutant Removal Effectiveness

Sediment	High
Nutrients	Low
Trash	Medium
Metals	High
Bacteria	Medium
Oil and Grease	High
Organics	High

The following is a partial list of the most common target pollutants for the Sacramento area: copper, lead, mercury, pathogens, diazinon, and chlorpyrifos. For more complete information refer to:

[http://www.waterboards.ca.gov/water\\_issues/programs/tmdl/integrated2010.shtml](http://www.waterboards.ca.gov/water_issues/programs/tmdl/integrated2010.shtml)

Source: CASQA California Stormwater BMP Handbook, January 2003

## Bioretention Planter

- Reduces peak flows during small storm events.
- Attractive and relatively easy to maintain.
- Potential LEED Credits
  - Credit 6.1 – Stormwater Design – Quantity Control
  - Credit 6.2 – Stormwater Design – Quality Control

### Limitations

- Not appropriate for industrial sites or locations where spills may occur, unless infiltration is prevented.
- Not suitable for steeply sloping areas.

### General Maintenance Recommendations (Low to Moderate)

- Periodically remove debris and sediment from planter.
- Repair/replace vegetation as necessary to maintain full cover.
- See Table BP-2 for additional vegetation maintenance recommendation.

## How Does a Bioretention Planter Work?

A bioretention planter is designed to receive runoff from downspouts, piped inlets or sheet flow from adjoining paved areas. A shallow surcharge zone above the vegetated surface temporarily stores runoff (the water quality volume or WQV). The runoff gradually infiltrates through the root zone of the vegetation and into the underlying sand/peat bed where it fills the pore spaces. A variety of natural mechanisms remove pollutants from the runoff as it infiltrates through the root zone and is detained in the sand/peat bed before reaching a base layer of gravel.



*Kindred Hospital, City of Folsom*

If infiltration to the underlying soil is not possible or desired, a flow-through bioretention planter with an impermeable bottom liner and underdrain should be used. The underdrain gradually dewateres the sand/peat bed over the drawdown period and discharges the runoff to the downstream storm drain system. If an infiltration planter is used, there is no impermeable bottom liner, and runoff percolates into the ground. An underdrain may still be needed if the permeability of the underlying soils is lower than the sand/peat layer (based on the recommendations of the project geotechnical engineer), but at least a portion of the treated runoff will infiltrate into the underlying soil. See Figures BP-1 and BP-2 for typical bioretention planter configurations.

*Other Names:* Stormwater Planter, Infiltration Planter, Flow-through Planter, Biofilter, Porous Landscape Detention, Rain Garden

## Planning and Siting Considerations

- For infiltration type planters, consult a geotechnical engineer about site suitability.
- Select location where site topography is relatively flat and allows runoff drainage to the bioretention planter.
- Integrate bioretention planters into other landscape areas when possible.
- Bioretention planters may be located within landscape areas as “rain gardens” and may have a non-rectangular footprint to fit the site landscape design.
- In expansive (C, D) soils, locate bioretention planters far enough from structures to avoid damage to foundations (as determined by a structural or geotechnical engineer). 10 feet is given as a rule-of-thumb on the first page of this fact sheet. Alternatively, use a flow-through bioretention planter.

---

### **Early Design is Critical!**

*Bioretention planters must be located on the site plan at the earliest possible design phase when laying out the building and parking footprints and before the site grading plan is prepared.*

---



*Dixie Ave Bioretention Planter, City of Sacramento*



*2500 River Plaza Drive, City of Sacramento*

## Design Criteria

Design criteria for bioretention planters are listed in Table BP-1. Use the Design Data Summary Sheet provided at the end of this fact sheet (Table BP-3) to record design information for the permitting agency’s review.

Details on bioretention specifications shall be included on improvement plans to aide in proper construction and implementation of the bioretention planter.

Table BP-1. Bioretention Planter Design Criteria

Design Parameter	Criteria	Notes
Contributing drainage area	≤ 1 acre	Ideally suited for small areas such as parking lot islands, perimeter building planters, street medians, roadside swale features, and site entrance or buffer features. Can be implemented on a larger scale, provided the WQV and average depth requirements are met.
Design volume	WQV or as dictated greater by SAHM modeling (for projects with hydromodification requirement)	See Appendix E in this Design Manual
Side slopes / sidewalls	Vertical sidewalls or side slopes of 3:1 or shallower	Bioretention planters typically have vertical sidewalls. Larger bioretention planters should have side slopes of 3:1 or shallower.
Design drawdown time	12 hrs	Period of time over which WQV drains from planter.
Design average surcharge depth (d <sub>s</sub> )	6-12 in	
Containment curb (if applicable)	Height > 6 in	Design to deter skateboarding and satisfy ADA requirements.
Inlet curb cuts (if applicable)	≥ 12 in wide	To prevent clogging and promote flow spreading. Pavement should be slightly higher than swale. Include energy dissipaters.
Top layer <sup>1</sup>	6 in (minimum)	Sandy loam topsoil. Deeper layer recommended for better vegetation establishment.
Bioretention soil media layer <sup>1</sup>	18 in (minimum)	Design mix to achieve approximately 5 in/hr infiltration rate and provide 12-hour drawdown; check with permitting agency for verification. See more detailed bioretention soil media specifications in Appendix I of this Design Manual.
Gravel layer	9 in	AASHTO #8 Coarse Aggregate
Filter fabric		Per project geotechnical engineer.
Minimum width	30 in	
Underdrain (as required)	3-4 inch perforated pipe	Typically for all flow-through planters, planters within 10 ft. of a building foundation, and infiltration planters where underlying soils have lower permeability than the planter's sand/peat media layer
Overflow device	Varies	Connect to storm drain system. See Figures BP-1 and BP-2 for recommended designs. Alternative designs may be allowed; check with permitting agency.

<sup>1</sup> See Construction Considerations below for recommendations regarding compaction

Design Parameter	Criteria	Notes
Waterproofing membrane		Per recommendations from project geotechnical engineer.
Vegetation		Appropriate for well-drained soil but will also withstand being inundated for periods of time.

## Design Procedure

### Step 1a – Calculate Water Quality Volume (WQV)

Using the calculations given in Appendix E, determine the contributing area and stormwater quality design volume, WQV, based on a 12-hour drawdown period.

### Step 1b – SAHM Modeling for Hydromodification Management (If applicable)

Upsize the bioretention planter volume as necessary based upon modeling results if implementing as a hydromodification control. Maintain depth so as to adhere with 12-hour maximum drawdown for WQV.

### Step 2 – Design average surcharge depth ( $d_s$ )

Select the average WQV depth between six (6) and twelve (12) inches. Average depth is defined as water volume divided by the water surface area of the planter. Use a maximum depth of six (6) inches if planters are located in the public right of way.

### Step 3 – Calculate planter surface area ( $A_s$ )

The design surface area of the planter is determined from the design WQV and depth ( $d_s$ ) as follows:

$$A_s = WQV/d_s \text{ (see Figures BP-1 and BP-2)}$$

### Step 4 – Design base courses

**Bottom Gravel layer** – Provide a 9-inch gravel layer (AASHTO #8 Coarse Aggregate)

**Bioretention Soil Media layer** – Provide an 18-inch (minimum) bioretention soil media layer over the gravel layer as shown in Figures BP-1 and BP-2. Place filter fabric between bioretention soil media and gravel layer.

**Top layer** – Provide a sandy loam top layer above the bioretention soil media layer. This layer should be a minimum of six (6) inches deep, but a deeper layer is recommended to promote healthy vegetation.

### Step 5 – Select subbase liner

If expansive soils are a concern, chemical or petroleum products are handled or stored within the contributing drainage area, or infiltration is not desired for any reason, use a flow-through

## Bioretention Planter

bioretention planter with an impermeable liner (see Figure BP-2). Otherwise, use an infiltration planter and install a non-woven geotextile membrane below the gravel layer to allow infiltration.

### Step 6 – Provide underdrain if needed

Provide a perforated underdrain pipe if the planter has an impermeable bottom liner or as required by the project geotechnical engineer. Size the underdrain to ensure a 12-hour drawdown and connect it to the downstream storm drain system. Place underdrain at the top of the gravel layer as shown in Figures BP-1 and BP-2.



*Historical District, The City of Folsom*

### Step 7 – Select vegetation

Select vegetation that:

- Is suited to well-drained soil but will withstand being inundated for periods of time;
- Will be dense and strong enough to stay upright, even in flowing water;
- Considers root systems and canopy (for trees, if any);
- Has minimum need for fertilizers;
- Is not prone to pests and is consistent with integrated pest management practices which promote less use of chemical pesticides; and
- Is consistent with local water conservation requirements.

The Alameda Countywide C.3 Stormwater Technical Guidance handbook contains a detailed plant list for consideration, although vegetation selection must be approved by the permitting agency. Potential options include: *Juncus baliticus* (Baltic rush), *Eleocharis macrostachya* (creeping spikerush), *Hordeum brachyantherum* (meadow barley), and *Muhlenbergia rigens* (deergrass), although other vegetation may also be appropriate. See Appendix J for additional plant selection guidance. Avoid the use of bark or similar buoyant material that will tend to float when the vegetated area is inundated. Check with the local agency's Ordinance if the planter will be used to satisfy landscaping requirements.

<https://cleanwaterprogram.org/index.php/resources/recources/development.html>

### Step 8 – Design overflow device

Provide an overflow device with an inlet to the storm drain system. Set the overflow inlet elevation above the WQV surcharge water level. A drop inlet or an overflow standpipe with an inverted opening are appropriate overflow devices (see Figures BP-1 and BP-2).



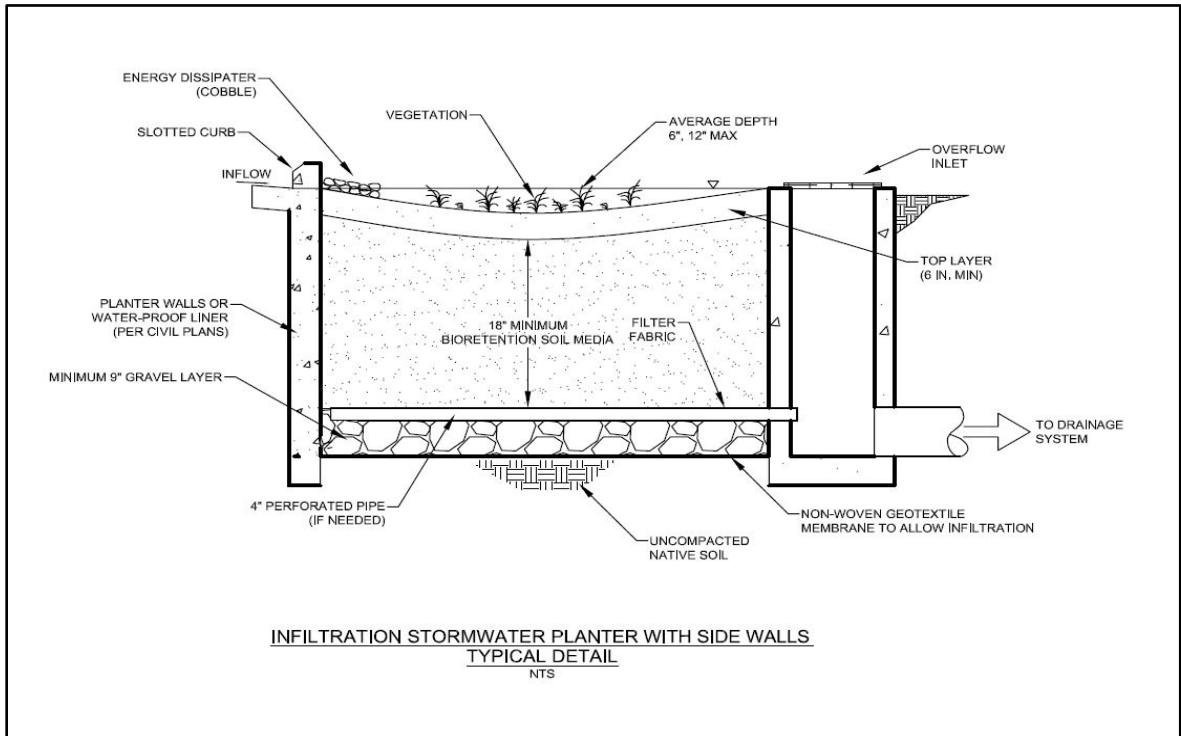

**Figure BP-1.**

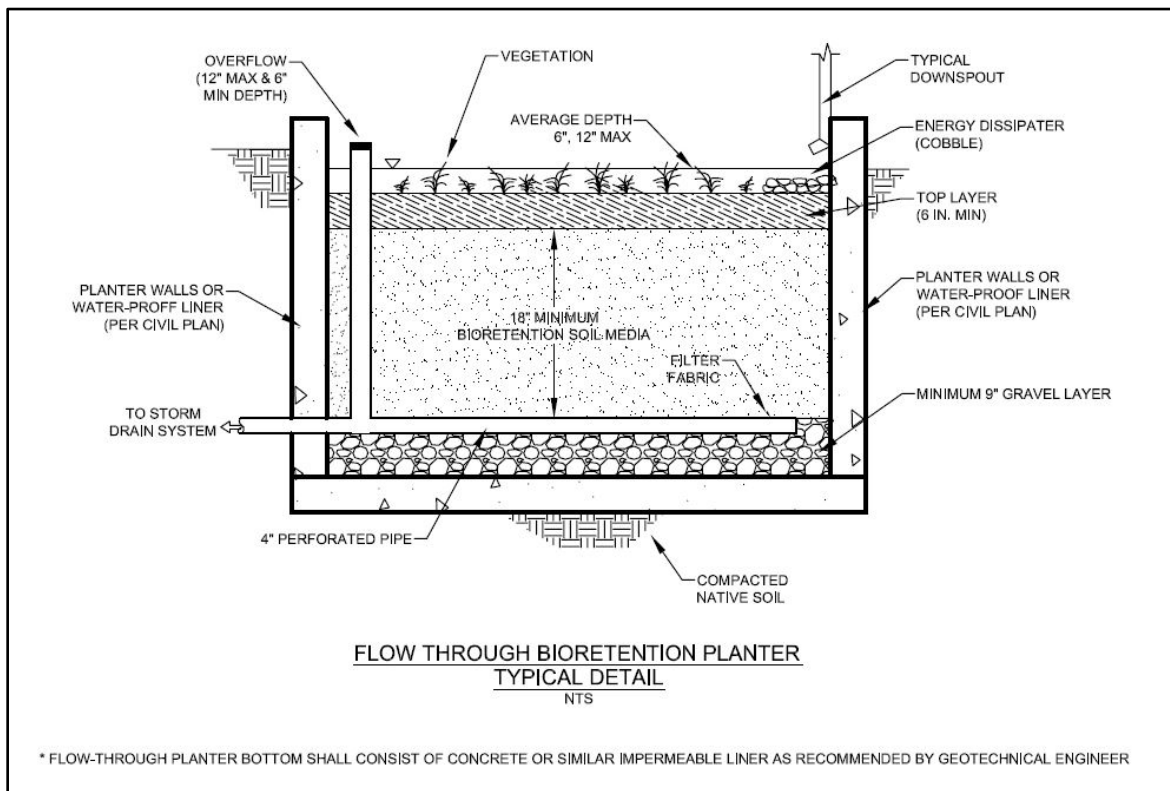

**Figure BP-2.**

*(other media mix and overflow design options may be allowed; check with permitting agency for verification)*

## Construction Considerations

- Divert runoff (other than necessary irrigation) during the period of vegetation establishment. Where runoff diversion is not possible, cover graded, seeded, and/or planted areas with suitable erosion control materials.
- For planters that are flush with the surrounding landscape, install sediment controls (e.g., staked straw wattles) around the planter to prevent high sediment loads from entering the planter during construction activities.
- Repair, seed, or re-plant damaged areas immediately.
- Place top layer and bioretention soil media layer each in 12” max lifts. Allow soil to settle naturally and boot compact after the final lift has been placed to achieve 80% to 85% relative compaction. No mechanical equipment shall be used to compact planters including vibratory plates.

## Long-term Maintenance

The local permitting agencies in the Sacramento area will require execution of a maintenance agreement or permit with the property owner for projects including a bioretention planter. Check with the local permitting agency about the timing for execution of the agreement. Such agreements will typically include requirements such as those outlined in Table BP-2. The property owner or his/her designee will be responsible for compliance. See Appendix B for additional information about maintenance requirements and sample agreement language.

*Table BP-2. Inspection and Maintenance Recommendations for Bioretention Planters*

Activity	Schedule
Trim vegetation (as applicable) and remove weeds to limit unwanted vegetation.	As needed
Remove litter and debris from landscape area.	As needed
Use integrated pest management (IPM) techniques to reduce use of chemical pesticides and herbicides.	Monitor for pests regularly and take other action as needed.
Inspect the planter to determine if runoff is infiltrating properly (i.e., perform a drawdown test).	At least twice per year during storm events. Additional inspections after periods of heavy runoff are desirable.
If infiltration is significantly reduced, remove and replace top layer and sand/peat layer.	May be required every 5 to 10 years or more frequently, depending on sediment loads.
Reconstruct or replace the control measure when it is no longer functioning properly.	See projected lifespan in Appendix B for informational purposes.
Prune trees and shrubs	Every 1-2 years

Table BP-3. Design Data Summary Sheet for Bioretention Planter

**Designer:** \_\_\_\_\_ **Date:** \_\_\_\_\_  
**Company:** \_\_\_\_\_  
**Project:** \_\_\_\_\_  
**Location:** \_\_\_\_\_

---

**1a. Determine Design Water Quality Volume**

a. Contributing drainage area Area = \_\_\_\_\_ ft<sup>2</sup>  
 b. Water Quality Volume WQV = \_\_\_\_\_ ft<sup>3</sup>

---

**1b. Adjust Volume Up for Hydromodification Management**  
 (If Applicable) Based upon SAHM Modeling

a. Water Quality Volume based on SAHM modeling V = \_\_\_\_\_ ft<sup>3</sup>  
 b. SAHM Model Demonstrates Compliance with Flow Duration Standards (Yes or No) \_\_\_\_\_

---

**2. Design average surcharge depth (d<sub>s</sub>)**  
 d<sub>s</sub> = 6-12 inches (0.5-1 foot) d<sub>s</sub> = \_\_\_\_\_ ft

---

**3. Design Planter Surface Area (A<sub>s</sub>)**  
 A<sub>s</sub> = WQV/d<sub>s</sub> A<sub>s</sub> = \_\_\_\_\_ ft<sup>2</sup>

---

**4. Base Course Layers**

a. Top Layer (6 in. minimum) \_\_\_\_\_ in  
 b. Bioretention Soil Media (18 in. minimum, See App I) \_\_\_\_\_ in  
 c. Gravel Layer (9 in. minimum) \_\_\_\_\_ in

---

**5. Planter Type (check type used)**

Infiltration without underdrain       Infiltration with underdrain  
 Flow-through with impermeable liner

---

**6. Vegetation (describe)** \_\_\_\_\_

---

**7. Overflow Device (check type used or describe "Other")**

Drop inlet       Standpipe  
 Other \_\_\_\_\_

---

**Notes:** \_\_\_\_\_

---

THIS PAGE INTENTIONALLY LEFT BLANK

# Compost-Amended Soil

---

## Description

The compost-amended soil BMP is an option that has a smaller footprint than impervious surface disconnection. This BMP option is less complex than both planter boxes and engineered infiltration BMPs. Compost refers to decomposed organic matter. A wide variety of compost products are available in bagged and bulk assortments. These may be a combination of plant-based compost, manure-based compost, bio-solids, and other agriculture by-products (such as chicken feathers). Compost made solely from plant-based products (such as wood chips and yard waste) are low in salts and preferred over manure-based composts, which are higher in salts. However, plant-based compost is generally more expensive (refer to the Limitations section below for more information on high-salt compost).



*Photo source: RBF Consulting*

## Siting Considerations

- Compost-amended soil is a cost-efficient alternative that can be used in residential or commercial settings seeking a spatially more efficient alternative to disconnection across permeable areas of unmodified “native” soils.
- Site compost-amended soil areas similar to other typical infiltration BMPs.

## Vector Considerations

- The potential for ponding water is limited based upon inherently shallow design depth. Although possible, the potential for vector breeding is generally low in a scenario involving a malfunctioning system.

## Advantages

- Compost-amended soil areas are a particularly strategic approach for sites with hydrologic soil groups “C” and “D”.
- Useful for street projects, roadways, and parking lot areas (with concurrence from the project geotechnical engineer).

## Compost-Amended Soil

- Potential LEED Credits
  - Credit 6.1 – Stormwater Design – Quantity Control
  - Credit 6.2 – Stormwater Design – Quality Control

## Limitations

- Compost-amended soil areas are not intended to incorporate sub-drain systems. As such they are not suitable for use in situations where infiltrated water, or water with excessive ponding poses an elevated risk of adverse consequence.
  - Not allowable for auto repair or retail gasoline sites.
  - May not be suitable for hillside development on slopes greater than 25%, and highly discouraged on slopes greater than 3:1 (only allowable with concurrence from the project geotechnical engineer).
- Compost-amended soil is not allowable in areas where the water table or bedrock is less and 10 feet from the surface.
- Most plants do not tolerate soils that are high in salts. Many forms of compost made with manure and bio-solids can be high in salts. Avoid using these amendments in soils that are naturally or have become high in salts (above 3 mmhos/cm<sup>1</sup>) and when plant establishment is desired. In such cases, choose a plant-based compost for soil amendment.
- Caution should be used in implementing compost-amended soils in watersheds impaired for nutrients or part of a nutrient TMDL.

## General Maintenance

- Routine inspection of compost-amended soils should evaluate factors that may decrease the soil's infiltration capacity, aeration, organic content, or cause diseased vegetation.
- Typical post-construction concerns include areas subject to compaction, hydric or waterlogged soils, poor cover conditions, unanticipated further development, and a decrease in organic content.
- Corrective actions for amended soils include restoring infiltration capacity of the soil by extensive mechanical aeration, deep tilling, and additional amendments. Any diseased vegetation should be removed and replaced.

---

<sup>1</sup> measurement of electrical conductivity in *milliohms per centimeter*

## Design Criteria

- Required surface area of amended soil is equal to 25% of the contributing impervious area.
- Required depth of amended soil can be determined from the equation below:

$$D_{BMP} = \frac{D_{DR} * R_V}{\emptyset * \frac{A_{BMP}}{A_{BMP} + A_I}}$$

Where  $D_{BMP}$  is the depth of the amended soil,  $D_{DR}$  is the design rainfall depth (synonymous with treatment requirement depth,  $P_o$ , see Appendix E),  $\emptyset$  is the amended soil porosity,  $R_V$  is the volumetric runoff coefficient of the total contributing area (see table below),  $A_{BMP}$  is the area of the amended soil, and  $A_I$  is the contributing impervious area. Soil porosity can generally be estimated at about 0.35. Other soil specific information regarding porosity and other physical characteristics can be obtained from textbooks or the NRCS Web Soil Survey. Refer to:

<http://websoilsurvey.sc.egov.usda.gov/App/HomePage.htm>

Percent Impervious	Volumetric Runoff Coefficient, $R_V$
20	0.17
40	0.28
60	0.41
80	0.60
100	0.89

- Provide suitably sized overflow and scour protection measures at the facility inlet. For projects using compost-amended soils for hydromodification management, the bypass design rate should be based upon events greater than  $Q_{10}$ . Refer to the local agency to confirm no additional requirements for bypass capacity.
- The amended soil bed should consist of approximately 12% to 15% compost by volume.
- The amended soil bed should be covered with 3" of mulch (4"-6" layer installed will typically settle down to a 3" layer). The finished grade of the mulch layer should be constructed as a shallow depressed area (2" typically). Do not use redwood or cedar mulch.
- Inclusion of a relief drain is optional at the designer's discretion to drain the facility in the event of a failure. This is highly recommended in high density residential and commercial settings. However, use of relief drains is not permissible in watersheds impaired for nutrients or part of a nutrient TMDL.

## Design Procedure

### General Design

Design criteria for compost-amended soil are listed in Table CAS-1. Use the Design Data Summary Sheet provided at the end of this fact sheet (Table CAS-3) to record design information for the permitting agency’s review.

*Table CAS-1 Compost-Amended Soil Design Criteria*

Design Parameter	Criteria	Notes
Compost-amended soil area to contributing impervious surface area ratio	0.25 minimum	
Design volume	WQV or as dictated greater by SAHM modeling (for projects with hydromodification requirement)	See Appendix E in this Design Manual for WQV. Volume provided should consider a 2" graded surface depression.
Design Depth	$D_{BMP} = \frac{D_{DR} * R_V}{\phi * \frac{A_{BMP}}{A_{BMP} + A_I}}$	Increase depth (if necessary)
Design drawdown time	48 hrs.	Period of time over which WQV drains from compost-amended soil area.
Amended soil compost content	12% to 15% by volume	
Mulch layer	3" minimum	Not redwood or cedar bark.
Relief drain (optional)	3 inch perforated pipe (minimum)	Not permissible in watersheds with nutrient impairment or TMDL.
Overflow device	WQR, or Q10 (for projects complying with hydromodification standards)	
Waterproofing membrane	Not permissible	

### Step 1 – Calculate amended compost surface area (A<sub>S</sub>)

The design surface area is to be a minimum of 0.25\*contributing impervious area.



### Step 2a – Calculate Water Quality Volume (WQV)

Using the calculations given in Appendix E, determine the contributing area and stormwater quality design volume, WQV, based on a 48-hour drawdown period.

### Step 2b – Adjust Design Volume (If necessary for hydromodification compliance)

For projects using compost-amended soil area to comply with hydromodification compliance provide additional area or compost-amended depth as necessary such that flow duration standards are satisfied based upon SAHM modeling.

### Step 2c – Adjust Design Depth (if necessary)

Adjust/increase depth if necessary to comply with the following equation described in previous sections within this fact sheet:

$$D_{\text{BMP}} = \frac{D_{\text{DR}} * R_V}{\phi * \frac{A_{\text{BMP}}}{A_{\text{BMP}} + A_I}}$$

### Step 3 – Design relief drain (optional)

Provide a 3” diameter perforated pipe and relief drain if desired by owner. Increase size and number of drains if necessary to accommodate actual size of compost-amended soil area. Not for use in nutrient impaired watersheds, or watersheds with a nutrient TMDL.

### Step 4 – Design overflow device

Size inflowing curb cuts or overflow risers based upon the water quality flow rate for the 85<sup>th</sup> percentile storm. Projects using compost-amended soil to comply with hydromodification management standards should size overflows for at least Q10, or as dictated greater by local agency standards.

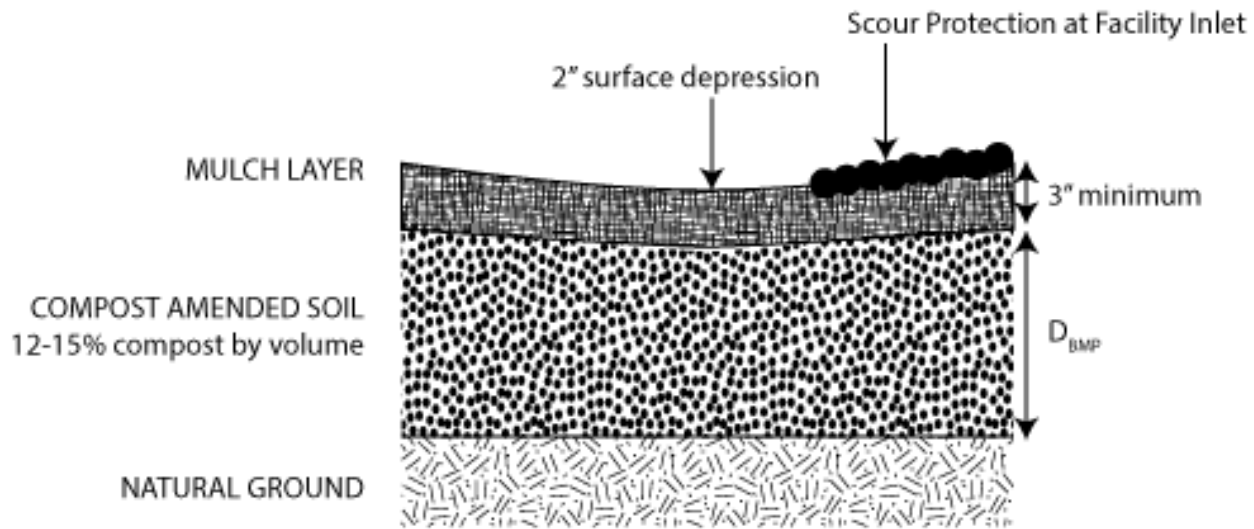

NOTES:

- Minimum surface area = 25% of contributing impervious area
- Overflow should be sized for  $Q_{10}$
- Increased size may be necessary for compliance with hydromodification management standards

Figure CAS-1 Compost-Amended Soil Section

## Construction Considerations

- Cultivate or hand-turn the compost matter thoroughly into the soil, while taking care not to encapsulate compost in clay or other native soils.

## Long term Maintenance

The local permitting agencies in the Sacramento area will require execution of a maintenance agreement or permit with the property owner for projects including a compost-amended soil area. Check with the local permitting agency about the timing for execution of the agreement. Such agreements will typically include requirements such as those outlined in Table CAS-2. The property owner or his/her designee will be responsible for compliance. See Appendix B for additional information about maintenance requirements and sample agreement language.

Table CAS-2 Inspection and Maintenance Recommendations for Compost-Amended Soils

Activity	Schedule
Trim vegetation (as applicable) and remove weeds to limit unwanted vegetation.	As needed
Add/replace mulch	As needed, typically every 1-2 years
Remove litter and debris from compost-amended soil area.	As needed
Use integrated pest management (IPM) techniques to reduce use of chemical pesticides and herbicides.	Monitor for pests regularly and take other action as needed.
Inspect the compost-amended soil area to determine if runoff is infiltrating properly (within 48 hrs).	At least twice per year during storm events. Additional inspections after periods of heavy runoff are desirable.
If infiltration does not meet the time requirement, perform mechanical aeration, deep tilling, and use of additional amendments. If that is not effective, remove and replace compost-amended soil in its entirety. Any diseased vegetation should be removed and replaced	May be required every 5 to 10 years or more frequently, depending on sediment loads.

## References Used to Develop This Fact Sheet

- Low Impact Development Center, *Fairfax County – LID BMP Fact Sheet – Soil Amendments*, February 28, 2005. [http://www.lowimpactdevelopment.org/ffxcty/5-1\\_soilamendments\\_draft.pdf](http://www.lowimpactdevelopment.org/ffxcty/5-1_soilamendments_draft.pdf)
- Colorado State University Extension, *Choosing a Soil Amendment*, Fact Sheet No. 7.235, June 2000 (revised February 2013). <http://www.ext.colostate.edu/pubs/garden/07235.pdf>
- Colorado State University Extension, *Soil Amendments*, CMG GardenNotes #241. <http://www.ext.colostate.edu/mg/gardennotes/241.html>.
- Low Impact Development Center, *Fairfax County – LID BMP Fact Sheet – Soil Amendments*, February 28, 2005. [http://www.lowimpactdevelopment.org/ffxcty/5-1\\_soilamendments\\_draft.pdf](http://www.lowimpactdevelopment.org/ffxcty/5-1_soilamendments_draft.pdf)
- Office of Water Protection, *Low Impact Development Standards Development, Stormwater Quality Design Manual Update and BMP Sizing Tool Enhancement – Task 1: Develop Low Impact Development (LID) Standards for New Development and Redevelopment Projects and Associated Work*, June 23, 2012.
- Virginia Cooperative Extension, *Best Management Practice Fact Sheet 4: Soil Restoration*, Publication 426-123. [http://pubs.ext.vt.edu/BSE/BSE-24/BSE-24\\_pdf.pdf](http://pubs.ext.vt.edu/BSE/BSE-24/BSE-24_pdf.pdf)

Table CAS-3. Design Data Summary Sheet for Compost-Amended Soils

Designer: \_\_\_\_\_ Date: \_\_\_\_\_

Company: \_\_\_\_\_

Project: \_\_\_\_\_

Location: \_\_\_\_\_

**1. Design Compost-Amended Soil Surface Area (A<sub>s</sub>)**

A<sub>s</sub> = 0.25\* Contributing Impervious Area A<sub>s</sub> = \_\_\_\_\_ ft<sup>2</sup>

**2a. Determine Design Water Quality Volume**

a. Contributing drainage area Area = \_\_\_\_\_ ft<sup>2</sup>  
 b. Water Quality Volume WQV = \_\_\_\_\_ ft<sup>3</sup>

**2b. Adjust Volume for Hydromodification Compliance (If Required)**

	PARAMETERS MODELED IN SAHM	ACTUAL DESIGN ON PLANS
Compost-Amended Soil Depth (D <sub>BMP</sub> =)	_____	_____
Compost-Amended Soil Porosity	_____	N/A
Native Infiltration Applied in Sub Grade (inches per hour)	_____	N/A
Total Storage Provided, Including 2" Surface Depression (ft <sup>3</sup> )	_____	_____
SAHM Model Demonstrates Compliance with Flow Duration Standards	(Yes or No) _____	

**2c. Double Check Design Depth (D<sub>BMP</sub>)**

$$D_{BMP} = \frac{D_{DR} * R_V}{\phi * \frac{A_{BMP}}{A_{BMP} + A_I}}$$

D<sub>BMP</sub> = \_\_\_\_\_ ft

**3. Relief Drain (check type used)**

- |  |   |
|--|---|
| <input type="checkbox"/> Relief Drain Provided       | <input type="checkbox"/> Relief Drain Not Provided      |
| <input type="checkbox"/> Nutrient Impairment or TMDL | <input type="checkbox"/> No Nutrient Impairment or TMDL |

Description of Relief Drain (Size, Elevation, etc.) \_\_\_\_\_

**4. Overflow Device (check type used or describe "Other")**

- |                                      |                                    |
|--------------------------------------|------------------------------------|
| <input type="checkbox"/> Curb Cut    | <input type="checkbox"/> Standpipe |
| <input type="checkbox"/> Other _____ |                                    |

Notes: \_\_\_\_\_

# Constructed Wetland Basin

## Description

A constructed wetland basin is an earthen basin treatment system with a permanent pool of water that includes four zones: a forebay, an open-water zone, a wetland zone with aquatic plants, and an outlet zone. The basin contains an area above the permanent pool to retain runoff from the stormwater quality design storm (water quality volume or WQV) and slowly release excess water over a specified drawdown period. Constructed wetland basins provide a significant natural amenity to a community. The basin pictured is located near Village Homes in Davis.



West David Pond. Photo: Larry Walker Associates

## Siting Considerations

- Contributing Drainage Area: typically greater than 20 acres.
- Soil Type: Most appropriate for Type C and D soils. For Type A and B soils, use an impermeable (e.g., clay) liner.
- Topography: Not appropriate on fill or steep slopes.

## Vector Considerations

- Potential for mosquitoes exists due to permanent water pool. However, proper design of permanent pool zones, routine vegetation management, and introduction of mosquito fish will minimize the risk.

Pollutant Removal Effectiveness	
Sediment	High
Nutrients	Medium
Trash	High
Metals	High
Bacteria	High
Oil and Grease	High
Organics	High

The following is a partial list of the most common target pollutants for the Sacramento area: copper, lead, mercury, pathogens, diazinon, and chlorpyrifos. For more complete information refer to:

[http://www.waterboards.ca.gov/water\\_issues/programs/tmdl/integrated2010.shtml](http://www.waterboards.ca.gov/water_issues/programs/tmdl/integrated2010.shtml)

Source: CASQA California Stormwater BMP Handbook, January 2003

## Advantages

- Reduces stormwater discharge to surface waters during most storm events.
- Reduces peak flows during small storm events.
- Can provide wildlife habitat, high aesthetic value, and passive recreational opportunities.
- Potential LEED Credits
  - Credit 6.2 – Stormwater Design – Quality Control

### Limitations

- Supplemental water supply or perennial base flow is required to maintain the permanent pool.
- Public safety related to access must be considered; security fencing is generally required by most permitting agencies in urban settings.
- Will typically require five years to establish.

### General Maintenance Recommendations (Moderate to High)

- Inspect basin annually in early spring.
- Periodically remove debris from inlet and outlet structures, and wetland basin itself.
- Regularly harvest vegetation and stock with mosquito fish for mosquito control.
- Remove accumulated sediment from forebay and other water zones as needed.
- Inspect seasonally for abnormal algae growth and address as needed.

## How Does a Constructed Wetland Basin Work?

Permanent pools of water are located throughout the constructed wetland basin, within: the forebay (which allows settling out of larger particles); an open water zone and a wetland zone with emergent vegetation (providing desired biodiversity); and the outlet zone (from which water is discharged to the downstream storm drain system or receiving water). An area above the permanent pool is designed to retain the stormwater quality design volume (WQV). The retained water mixes with and displaces water from the permanent pool, which drains to the downstream storm drain system or receiving water over the design drawdown period (48 hours for WQV). Much of the water discharged during and following a storm event is water displaced from the permanent pool which has previously been treated by natural processes.

---

*Constructed wetland basins should not be confused with wet detention basins (wet ponds) which are presented elsewhere in this manual. Constructed wetland basins are shallower and feature more vegetative coverage than wet detention basins.*

---

Treatment of the runoff occurs through a variety of natural mechanisms that occur in the wetland, including sedimentation, filtration, adsorption, and biological uptake. The aquatic plants provide energy dissipation and pollutant removal by enhancing sedimentation and providing biological uptake.

Supplemental water or perennial baseflow is needed to maintain the permanent pool at all times.

## Planning and Siting Considerations

- Integrate constructed wetland basins into open space, natural areas, and other planned landscaped areas when possible. Avoid placing features in open space and wetland preserves where future maintenance of the water quality facility will be restricted or prohibited.
- Provide aesthetic security fencing if required by the permitting agency.

## Design Criteria

Design criteria for constructed wetland basins are listed in Table CWB-1. Use the Design Data Summary Sheet provided at the end of this fact sheet (Table CWB-4) to record design information for the permitting agency's review.

## Design Procedure

### Step 1a – Calculate Water Quality Volume (WQV)

Using the Appendix E in this Design Manual, determine the contributing drainage area and stormwater quality design volume (WQV) for 48-hour drawdown.

### Step 1b – SAHM Modeling for Hydromodification Management (If applicable)

Upsize the constructed wetland basin volume as necessary based upon modeling results if implementing as a hydromodification control. Maintain depth so as to adhere with 48-hour maximum drawdown for WQV.

---

Use the **Design Data Summary Sheet** (Table CWB-4) to record design information for the permitting agency's review.

---

### Step 2 – Determine Basin Minimum Volume for Permanent Pool

The volume of the permanent wetland pool ( $V_{pp}$ ) shall be not less than 75% of the WQV.

$$V_{pp} \geq 0.75 \times \text{WQV}$$

### Step 3 – Determine Basin Depths and Surface Areas

Distribution of the wetland area is needed to achieve desired biodiversity. Distribute component areas as indicated in Table CWB-2.

- Estimate average depth of permanent pool ( $D_{avg}$ ) including all zones
- Estimate the water surface area of the permanent pool ( $A_{pp}$ ) based on actual  $V_{pp}$

$$A_{pp} = V_{pp} / D_{avg}$$

- Estimate water surface elevation of the permanent pool (WS Elev<sub>pp</sub>) based on site elevations.

## Constructed Wetland Basin

Table CWB-1. Constructed Wetland Basin Design Criteria

Design Parameter	Criteria	Notes
Design volume	WQV or as dictated greater by SAHM modeling (for projects with hydromodification requirement)	See <i>Standard Calculation Fact Sheet</i>
Maximum drawdown time for WQV	48 hours	Based on WQV
Minimum permanent pool volume	75%	Percentage of WQV
Liner	Clay	Required in areas with very permeable soils (e.g., Types A,B)
Inlet/outlet erosion control	-	Provide energy dissipaters to reduce velocity, subject to the approval of the permitting agency
Forebay Volume Area Depth Liner	5-10% 5-10% 4 ft	Percentage of WQV Percentage of permanent pool surface area Minimum Concrete, to facilitate maintenance
Open-water Zone Area (including forebay) Depth	10-50% 4 ft	Percentage of permanent pool surface area Minimum
Wetland Zone Area Depth	50-70% 0.5-1 ft	Percentage of permanent pool surface area 30 to 50% should be 1.0 ft deep
Outlet Zone Area Depth	5-10% 3 ft	Percentage of permanent pool surface area Minimum
Surcharge depth above permanent pool	2 ft	Maximum
Basin length to width ratio	2:1	Minimum (larger preferred)
Basin freeboard	1 ft	Minimum
Wetland zone bottom slope	10%	Maximum
Embankment side slope (H:V)	4:1 3:1	(or steeper) Inside Outside (without retaining walls)
Side slopes (H:V)	5:1	
Maintenance access ramp slope (H:V)	10:1	or flatter
Maintenance access ramp width	5-20 ft	Minimum. Paved with concrete or porous pavement, subject to approval of permitting agency



Table CWB-2. Distribution of Wetland Components

Components	% Permanent Pool Surface Area	Design Water Depth
Forebay	5-10%	4 feet (minimum)
Open water zone	10-50%	4 feet (minimum)
Wetland zones with emergent vegetation	50-70%	6 to 12 inches (30 to 50% of this area should be 1 foot deep with bottom slope $\leq$ 10%)
Outlet zone	5-10%	3 feet (minimum)

#### Step 4 – Determine Surcharge Depth of WQV above Permanent Pool and Maximum Water Surface Elevation

The surcharge depth of the WQV above the permanent pool's water surface ( $D_{WQV}$ ) should be  $\leq$  2.0 feet.

- Estimate WQV surcharge depth ( $D_{WQV}$ ) based on  $A_{pp}$ .  

$$D_{WQV} = WQV/A_{pp}$$
- If  $D_{WQV} > 2.0$  feet, adjust value of  $V_{pp}$  and/or  $D_{avg}$  to increase  $A_{pp}$  and yield  $D_{WQV} \leq 2.0$ . The water surface of the basin will be greater than  $A_{pp}$  when the WQV is added to the permanent pool.
- Estimate maximum water surface area ( $A_{WQV}$ ) with WQV based on basin shape.
- Recalculate Final  $D_{WQV}$  based on  $A_{WQV}$  and  $A_{pp}$ . Note:  $V_{pp}$  and/or  $D_{avg}$  can be adjusted to yield Final  $D_{WQV} \leq 2.0$  feet.

$$\text{Final } D_{WQV} = WQV/((A_{WQV} + A_{pp})/2)$$

- Calculate maximum water surface elevation in basin with WQV.

$$\text{WS Elev}_{WQV} = \text{WS Elev}_{pp} + \text{Final } D_{WQV}$$

#### Step 5 – Determine Inflow Requirement

A net inflow of water must be available at all times through a perennial base flow or supplemental water source. Use the following equation and parameters to estimate the quantity of monthly inflow required at various times of the year. The maximum monthly requirement will govern the design requirement.

$$Q_{\text{inflow}} = Q_{E-P} + Q_{\text{seepage}} + Q_{ET}$$

Where:

$Q_{\text{inflow}}$  = Estimated base flow (acre-ft/mo.) (Estimate by seasonal measurements and/or comparison to similar watersheds)

$Q_{E-P}$  = Loss due to evaporation minus the gain due to precipitation (acre-ft/mo.)

## Constructed Wetland Basin

$Q_{\text{seepage}}$  = Loss or gain due to seepage to groundwater (acre-ft/mo.)

$Q_{\text{ET}}$  = Loss due to evapotranspiration (additional loss through plant area above water surface not including the water surface) (acre-ft/mo.)

Note that an impermeable liner may be required to maintain permanent pool level in areas with extremely permeable soils.

### Step 6 – Design Basin Forebay

The forebay provides a location for sedimentation of larger particles and has a solid bottom surface to facilitate mechanical removal of accumulated sediment. The forebay is part of the permanent pool and has a water surface area comprising 5 to 10% of the permanent pool water surface area and a volume comprising 5 to 10% of the WQV. The depth of permanent pool in the forebay should be a minimum of 4 feet. Provide the forebay inlet with an energy dissipation structure and/or erosion protection. Trash screens at the inlet are recommended to keep trash out of the basin.

### Step 7 – Design Outlet Works

Provide outlet works that limit the maximum water surface elevation to WS Elev<sub>WQV</sub>. The outlet works are to be designed to release the WQV over a 48-hour period. Protect the outlet from clogging with a trash rack and a skimmer shield that extends below the outlet and above the maximum WQV depth. A single orifice outlet control is shown in Figure CWB-1.

- For single orifice outlet control or single row of orifices at the permanent pool elevation (WS Elev<sub>pp</sub>) (see Figure CWB-1), use the orifice equation based on the WQV (ft<sup>3</sup>) and depth of water above orifice centerline D (ft) to determine orifice area (ft<sup>2</sup>):

Orifice Equation

$$Q = C \times A \times (2gD)^{1/2}$$

Where:

Q = Flow rate, (cfs)

C = Orifice coefficient (use 0.61)

A = Area of orifice, (ft<sup>2</sup>)

g = Acceleration due to gravity (32.2 ft/sec<sup>2</sup>)

D = Depth of water above orifice centerline (D<sub>WQV</sub>)

The equation can be solved for A based on the WQV and using a design drawdown time (t) of 48 hours.

- For perforated pipe outlets or vertical plates with multiple orifices, use the following equation to determine required area per row of perforations, based on the WQV (acre-ft) and depth of water above centerline of the bottom perforation D (ft).

$$\text{Area/row (in}^2\text{)} = WQV/K_{48}$$

Where:

$$K_{48} = 0.012D^2 + 0.14D - 0.06 \text{ (from Denver UDFCD, 1999)}$$

Select appropriate perforation diameter and number of perforations per row (columns) with the objective of minimizing the number of columns and using a maximum perforation diameter of 2 inches. Rows are spaced at 4 inches on center from the bottom perforation. Thus, there will be 3 rows for each foot of depth plus the top row. The number of rows (nr) may be determined as follows:

$$nr = 1 + (D \times 3)$$

Calculate total outlet area by multiplying the area per row by number of rows.

$$\text{Total Orifice Area} = \text{area/row} \times nr$$

### Step 8 – Design Basin Shape

Whenever possible, shape the basin with a gradual expansion from the inlet and a gradual contraction toward the outlet. The recommended length to width ratio is between 2:1 to 4:1, with 3:1 optimal. Internal baffling with berms or modification of inlet and outlet points may be necessary to achieve this ratio.

### Step 9 – Design Basin Side Slopes

Side slopes should be stable and sufficiently gentle to limit rill erosion and to facilitate maintenance. Internal side slopes should be no steeper than 4:1; external side slopes should be no steeper than 3:1.

### Step 10 – Design Maintenance Access

Provide for all-weather access for maintenance vehicles to the bottom and outlet works. Maximum grades of access ramps should be 10 percent and minimum width will vary according to local permitting agency requirements, but usually between 15-20 feet. Pave ramps with concrete or porous pavement, subject to the approval of the permitting agency.

### Step 11 – Design Security Fencing

To protect habitat and for safety reasons, provide aesthetic security fencing approved by the permitting agency around the basin, except when specifically waived by the permitting agency.

### Step 12 – Select Vegetation

Select wetland vegetation appropriate for planting in the wetland bottom. Consider the water fluctuations that are likely to occur. Consult a qualified wetland specialist regarding selection and establishment of plants. The shallow littoral bench should have a 4- to 6-inch layer of organic topsoil. Berms and sidesloping areas should be planted with native or irrigated turf grasses. Shrubs and trees may also be incorporated where appropriate.

## Construction Considerations

- If possible, stabilize the entire contributing drainage area to the basin before construction begins. If this is not possible, divert flow around the basin to protect it from sediment loads during construction. If sediment does enter the facility during construction, the contractor will be required to remove soil from the basin floor after the entire site has been stabilized, to the satisfaction of the permitting agency inspector.
- Prevent construction traffic from entering basin.
- Ensure that final grading produces a level basin bottom without low spots or depressions.
- Install seepage collars on outlet piping to prevent seepage through embankments.

## Maintenance during Vegetation Establishment

- Control the permanent pool water levels as necessary to allow establishment of wetland plants (typically up to 5 years); raise it to the final operating level after plants are established.
- Inspect frequently during vegetation establishment, and identify and re-plant areas immediately as needed.

## Long-term Maintenance

The local permitting agencies in the Sacramento area will require execution of a maintenance agreement or permit with the property owner for projects including a constructed wetland basin. Check with the local permitting agency about the timing for execution of the agreement. Such agreements will typically include requirements such as those outlined in Table CWB-3. The property owner or his/her designee will be responsible for compliance. See Appendix B for additional information about maintenance requirements and sample agreement language.

*Table CWB-3. Inspection and Maintenance Recommendations for Constructed Wetland Basins*

Activity	Schedule
Inspect basin to identify potential problems such as trash and debris accumulation, damage from burrowing animals, and sediment accumulation.	At beginning and end of the wet season. Additional inspections after periods of heavy runoff are desirable.
Remove litter and debris from constructed wetland basin area.	As required.
Pruning and general tree care, if applicable.	Every 3-5 years.
Stock basin with mosquito fish to enhance natural mosquito and midge control. Contact the local vector control district for assistance.	As required.
Harvest vegetation for vector control and to maintain open water surface area.	Annually or more frequently if required.
Remove sediment from forebay and other zones when accumulation reaches 10 percent of original design depth or if re-suspension is observed. (Note: Sediment removal may not be required in the main pool area for as long as 20 years.)	Clean in early spring so vegetation damaged during cleaning has time to reestablish.
Reconstruct or replace the control measure when it is no longer functioning properly.	See projected lifespan in Appendix B for informational purposes.

# Constructed Wetland Basin

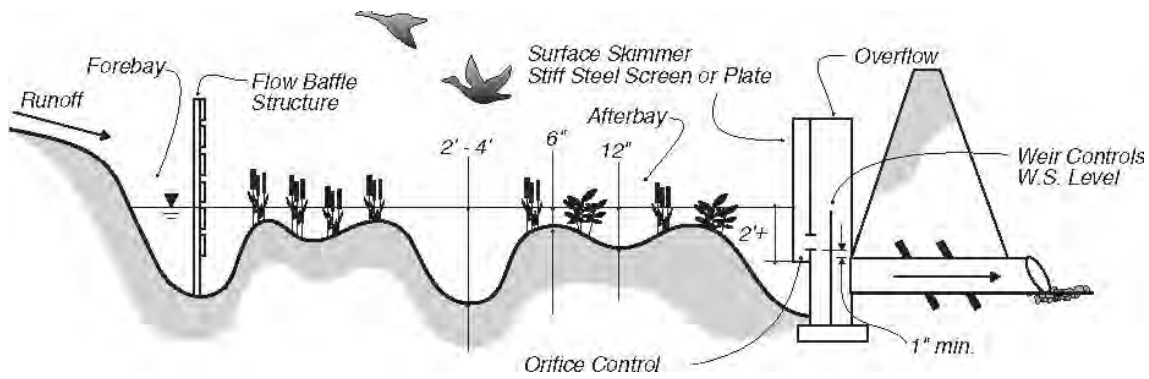
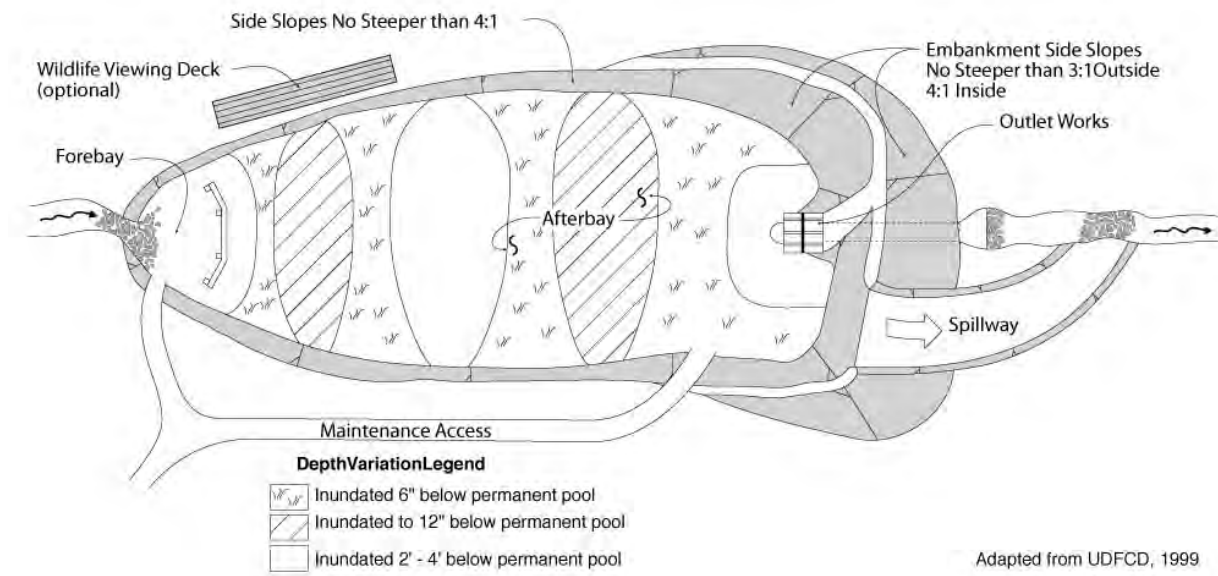

Figure CWB-1. Constructed Wetland Basin

Table CWB-4. Design Data Summary Sheet for Constructed Wetland Basin (Page 1 of 3)

<b>Designer:</b> _____	<b>Date:</b> _____
<b>Company:</b> _____	
<b>Project:</b> _____	
<b>Location:</b> _____	

---

**1a. Design Water Quality Volume**

a. Contributing drainage area	Area =	_____ ft <sup>2</sup>
b. Water Quality Volume	WQV =	_____ ft <sup>3</sup>

---

**1b. Adjust Volume Up for Hydromodification Management**  
(If Applicable) Based upon SAHM Modeling

a. Water Quality Volume based on SAHM modeling	V =	_____ ft <sup>3</sup>
b. SAHM Model Demonstrates Compliance with Flow Duration Standards	(Yes or No)	_____

---

**2. Wetland Basin Minimum Permanent Pool Volume**  
(Vol<sub>pp</sub> ≥ 0.75 x WQV)

Vol <sub>pp</sub> =	_____	acre-ft
---------------------	-------	---------

---

**3. Wetland Basin Depths and Water Surface Areas**

	<b>ACTUAL DESIGN</b>
a. Permanent pool volume (Vol <sub>pp</sub> )	Vol <sub>pp</sub> = _____ acre-ft
Average depth of permanent pool (D <sub>avg</sub> )	D <sub>avg</sub> = _____ ft
Water surface area of permanent pool (A <sub>pp</sub> )	A <sub>pp</sub> = _____ ft <sup>2</sup>
Water surface elevation of permanent pool (WS Elev <sub>pp</sub> )	WS Elev <sub>pp</sub> = _____ ft
b. Forebay	
Depth range = minimum 4 ft	Depth = _____ ft
Volume range = 5-10% of WQV	Volume = _____ acre-ft
Water surface area range = 5-10% of A <sub>pp</sub>	WS Area = _____ ft <sup>2</sup>
c. Open Water Zone	
Depth Range = minimum 4 ft	Depth = _____ ft
Water surface area range = 30-50% of A <sub>pp</sub>	WS Area = _____ ft <sup>2</sup>
d. Wetland Zones with Emergent Vegetation	
Depth Range = 6-12 inches	Depth = _____ ft
Water surface area range = 50-70% of A <sub>pp</sub>	WS Area = _____ ft <sup>2</sup>
e. Outlet Pool	
Depth Range = minimum 3 ft	Depth = _____ ft
Water surface area range = 5-10% of A <sub>pp</sub>	WS Area = _____ ft <sup>2</sup>

---

Design Data Summary Sheet for Constructed Wetland Basin (Page 2 of 3)

Project: \_\_\_\_\_

**4. Surcharge Depth of WQV and Max WS Elevation**

- a. Maximum water surface area with WQV ( $A_{WQV}$ )  $A_{WQV} =$  \_\_\_\_\_  $ft^2$
- b. Surcharge depth of WQV ( $D_{WQV} \leq 2.0$  ft)  $D_{WQV} =$  \_\_\_\_\_  $ft$   
 Final  $D_{WQV} = WQV / ((A_{WQV} + A_{pp}) / 2)$
- c. Maximum water surface elevation with WQV (WS Elev<sub>WQV</sub>)  $WQ$  Elev<sub>WQV</sub> = \_\_\_\_\_  $Ft$

**5. Determine Maximum Month Inflow Requirement**

- $Q_{inflow} = - Q_{E-P} + Q_{seepage} + Q_{ET}$   $Q_{E-P} =$  \_\_\_\_\_  $acre-ft/mo$
- $Q_{seepage} =$  \_\_\_\_\_  $acre-ft/mo$
- $Q_{ET} =$  \_\_\_\_\_  $acre-ft/mo$
- $Q_{inflow} =$  \_\_\_\_\_  $acre-ft/mo$

**6. Outlet Works**

- a. Outlet Type (check one)
  - Single Orifice
  - Multi-orifice Plate
  - Perforated Pipe
  - Other
- b. Depth of water above bottom orifice ( $D_{WQV}$ )  $Depth =$  \_\_\_\_\_  $ft$
- c. Single Orifice Outlet
  - Total Area  $A =$  \_\_\_\_\_  $in^2$
  - Diameter (or L x W)  $D =$  \_\_\_\_\_  $in$
- d. Multiple Orifice Outlet
  - Area per Row of Perforations  $A =$  \_\_\_\_\_  $in^2$
  - Perforation Diameter (2 inch maximum)  $D =$  \_\_\_\_\_  $in$
  - No. of Perforations (columns) per Row  $Perforations =$  \_\_\_\_\_
  - No. of Rows (4-inch spacing)  $Rows =$  \_\_\_\_\_
  - Total Orifice Area  $Area =$  \_\_\_\_\_  $in^2$   
 (Area per Row) x (No. of Rows)

**7. Basin Shape: Length-Width Ratio (2:1 minimum)**  $Ratio =$  \_\_\_\_\_  $L:W$

**8. Embankment Side Slope**

- a. Interior Side Slope (4:1 or steeper)  $Slope =$  \_\_\_\_\_  $L:W$
- b. Exterior Side Slope (3:1)  $Slope =$  \_\_\_\_\_  $L:W$

**9. Maintenance Access Ramp**

- a. Slope (10% maximum)  $Slope =$  \_\_\_\_\_  $\%$
- b. Width (15 to 20 feet)  $Width =$  \_\_\_\_\_  $ft$



*Design Data Summary Sheet for Constructed Wetland Basin (Page 3 of 3)*

**Project:** \_\_\_\_\_

**10. Vegetation (describe)**

Native Grasses \_\_\_\_\_

Irrigated Turf \_\_\_\_\_

Emergent Aquatic Plants (specify type/density) \_\_\_\_\_

Other \_\_\_\_\_

**Notes:** \_\_\_\_\_  
\_\_\_\_\_

THIS PAGE INTENTIONALLY LEFT BLANK

# Disconnected Pavement

---

## Description

Disconnected pavement is any impervious pavement designed to sheet flow runoff over adjoining vegetated areas or porous pavement before it reaches the storm drain system. As the runoff slows and travels through vegetation or over a porous surface, water is infiltrated into the soil with some pollutant removal through filtration.

*It is recommended that you read the Porous Pavement BMP Fact Sheet before using this one. Also, Alternative Driveway Design is a technique which employs principles from this and the Porous Pavement BMP Fact Sheet.*



*Divided sidewalks in a new residential subdivision are one form of disconnected pavement.*

*Photo: ECORP Consulting*

## Siting Considerations

- Soils: Appropriate for all soil types but porous pavement requires an underdrain for soil types C and D.
- Grade: 10% maximum.
- Traffic loading: Select and design surface material with consideration of anticipated load.

## Vector Considerations

- Potential for mosquitoes due to standing water in vegetated features will be greatly reduced or eliminated if the feature is properly designed, constructed, and maintained to ensure complete drainage.

## Advantages

- Takes advantage of already-required landscape areas; no additional space required.
- Can reduce size of downstream stormwater quality treatment measures by reducing the volume required to treat.
- Vegetated areas provide green space. Combination of impervious and porous pavement can be more attractive than traditional installation.
- Potential LEED Credits
  - Credit 6.1 – Stormwater Design – Quantity Control

## Disconnected Pavement

### Limitations

- Do not use without appropriate source control BMPs on sites with a likelihood of oil, grease or other hazardous spills.

### Maintenance Recommendations (Low to Moderate<sup>1</sup>)

- See inspection and maintenance recommendations in the Porous Pavement fact sheet.

## How Does Disconnected Pavement Work?

Impervious surfaces, such as those paved with regular asphalt or concrete, that convey stormwater to a storm drain system without allowing the water to flow over any impervious surface are considered “directly connected.” Compared to pervious areas, directly connected impervious surfaces contribute increased runoff and associated pollutants to the downstream storm drain system. “Disconnection” of impervious surfaces can be achieved by sloping surfaces toward relatively small or narrow vegetated or porous areas where the water is filtered before entering the storm drain system, and/or infiltrated into the underlying soils. Areas that can be disconnected include parking lots, driveways, sport courts, sidewalks, patios, courtyards, and roadways.



*Gravel walkway in the River Garden,  
The City of Elk Grove*

*Other names:* Not directly connected pavement, divided sidewalks, separated sidewalks, bifurcated walk.

## Planning and Siting Considerations

- Maximize the use of landscaping and natural areas that are planned for the site already. Design landscaping to sit below adjacent impervious surfaces. The width of the vegetation needed is dependent on the area of contributing pavement; the ratio of impervious to pervious surface should be 2:1 or less.
- When draining pavement to open spaces, avoid environmentally-sensitive and protected wetlands areas. These applications will not qualify for the runoff reduction credits discussed in this fact sheet.
- Check with the local permitting agency to determine if credit will be given for paved surfaces draining to vegetated creek buffer areas.

---

<sup>1</sup> As compared to treatment control measures.

- Locate porous features in well drained soils (Types A or B) whenever possible. If porous pavement is used in C or D soils, an underdrain will be required.
- Eliminate curbs and slope pavement to sheet flow into vegetation where possible. Where curbs are required for safety or other reasons, use curb cutouts to convey flow into the vegetation.
- Maximize the use of Porous Pavement (as an alternative to conventional pavement) where it can double as a disconnected conveyance zone. When draining an impervious area into porous pavement, refer to Porous Pavement Fact Sheet elsewhere in this chapter for planning and design requirements.

## Suitable Land Use Types

**Residential:** Driveways, patios, and walkways can be disconnected. Also see Alternative Driveways Fact Sheet elsewhere in this chapter.

**Commercial:** Plazas and courtyards, parking lots/stalls, overflow parking areas, some types of storage areas, walkways, and as entryway features. Not appropriate for retail gas outlets, auto maintenance businesses or locations where spills may occur.

**Industrial:** Employee parking stalls, entryway, and pedestrian walk features. Not appropriate for processing/manufacturing areas involving extractive, chemical/petroleum, food, printing processes, and chemical storage areas.

**Roadways:** Slope roadways to drain across vegetation or other porous surfaces.

**Parks and Open Space:** Parking lots, park hardscape areas, pedestrian and bike trails, sports courts and playgrounds. See notes above about draining to natural open spaces, environmentally-sensitive areas and creek buffers.

## Variations

Two variations of disconnected pavement that qualify for runoff reduction credits are discussed in this fact sheet: 1) Pavement draining to landscaping, and 2) pavement draining to porous pavement.

### Pavement Draining to Landscaping

Vegetated areas used to disconnect impervious surfaces can include either uniformly graded formal landscape features or densely vegetated open space/natural areas on the site. The impervious surface must sheet flow into and through the vegetated area to promote filtration and settling. These vegetated features differ



*Curb cutouts deliver runoff from a parking lot to a vegetated swale. Vegetation must be lower than pavement to prevent clogging and sediment buildup at the curb. Photo: City of Fremont*

## Disconnected Pavement

from Vegetated Filter Strips (see fact sheet elsewhere in this chapter) as they collect runoff from very small areas, more variability in dimension is allowed and they do not qualify as “treatment” techniques per Table 3-2 (Selection Matrix). Look for opportunities to use small pockets of landscaping and strips of turf grass for this application. The ratio of impervious to pervious surfaces must be 2:1 or less to qualify for the runoff reduction credits presented in this manual.

### *Examples:*

**Sidewalks** – Establish a vegetated strip between sidewalks and the curb and gutter system in the street to allow for infiltration and filtration of sidewalk runoff.

**Driveways** – Slope residential driveways toward yard vegetation or divert flow from the driveway to the yard through a slotted trench or other approved means. See the Alternative Driveways Fact Sheet elsewhere in this chapter for more information.

**Plazas, patios and walkways** – Consider constructing these surfaces using porous pavement materials (see Porous Pavement fact sheet elsewhere in this chapter) to reduce imperviousness and reduce runoff. If that is not possible, slope the impervious areas to sheet flow into adjacent vegetated areas.

**Commercial parking lots** – Parking lot landscape areas between stalls or at the lot perimeter (typically already required by permitting agency codes) can be designed to double as stormwater quality control measures. As a first choice, design these areas to treat and filter parking lot runoff by integrating vegetated swales or bioretention planters (see fact sheets for these measures elsewhere in this chapter). For smaller landscape pockets where it is infeasible to run the water through vegetated swales or bioretention planters, apply the disconnected pavement concept to reduce runoff. Grade the parking areas to drain to these features, with slotted curbs or curb cutouts to allow the runoff to flow into and through the vegetation (see photo). This may help reduce the size of needed downstream treatment measures for the site.

## Pavement Draining to Porous Pavement

Consider replacing or combining conventional paved surfaces (concrete, asphalt) with porous paved surfaces to meet paving area requirements, in order to accept and infiltrate runoff from adjoining impervious surfaces. The porous pavement may be any of the variations described in the Porous Pavement fact sheet presented elsewhere in this chapter.



*Use of reinforced grass pavement (“grasscrete”) allows for pedestrian access without vegetation damage and reduces runoff through infiltration.  
Photo: Alameda Countywide Clean Water Program*



*Photo: Lions Park, The City of Folsom*

*Examples:*

**Divided Sidewalks and parking lot medians –**

Consider the use of porous pavement in vegetated sidewalk strips and parking lot medians to provide paths for pedestrians to walk across the area without damaging vegetation. See photo.



*Pavers in parking lot. Photo: City of Emeryville*

**Hybrid Parking Lot** - Traffic loading requirements typically differ between parking lot drive aisles and stalls in parking lots. More durable conventional pavement surfaces will typically be required for the main drive aisles and areas used by garbage, delivery and fire trucks, while porous pavement may be appropriate for the stalls (or a portion of the stalls) used by cars. The permeable stalls may

be used to carry flow from the main drive aisles to the storm drain system, allowing for infiltration and disconnecting the main aisle pavement from the system. A water barrier may be required between regular load-bearing pavement/streets and porous pavement materials to keep water from undermining the regular pavement subbase; verify this with the local permitting agency.

This hybrid parking lot concept has been applied successfully in many areas of the country, including the San Francisco Bay Area. Generally, pervious pavement or cobblestone block set in sand will be preferred by the permitting agency, however, depending on frequency and type of use, modular block pavement, reinforced grass, or gravel may be appropriate. For example, these techniques could work well in a seasonal overflow parking lot, a public park or a trailhead.

In hybrid parking lots, stall markings can be indicated with one of several techniques, depending on the type of permeable surface: wood headers laid in a field of pervious pavement, a change in cobblestone block color, concrete bands, or rounded raised pavement markers similar to those used on highways (“Botts’ Dots”). (*Start at the Source*, 1999)

**Bike and Pedestrian Trails** –Consider the use of gravel or other porous material alongside bike and pedestrian trails to infiltrate and filter some of the runoff. For example, the City of Folsom requires a gravel shoulder for its Class I bike trails.

## Design Criteria

Design criteria for disconnected pavement are listed in Table DP-1.

## Construction Considerations

- Ensure that flow entering a porous area from an impervious surface is spread evenly and the area accepting the flow is lower than the impervious surface.
- If using porous pavement, follow the construction guidelines given in the Porous Pavement Fact Sheet located elsewhere in this chapter.
- Once construction is complete, stabilize the entire contributing drainage area and the vegetation within the feature itself, before allowing runoff to enter the feature.

## Long-term Maintenance Recommendations

Refer to the inspection and maintenance recommendations in the Porous Pavement fact sheet.

*Table DP-1. Disconnected Pavement Design Criteria*

Variation/Design Parameter	Criteria
<b>Pavement Draining to Landscaping</b>	
Impervious Surface	Spread sheet flow into vegetated area (to maximize contact with vegetation) using curb cutouts or notches as acceptable to local permitting agency.
Impervious-Porous Ratio	2:1 maximum (see Appendix D)
Vegetation	Ensure that there are no channels, low conveyance areas, or other features that would cause short-circuiting.  Plant with dense vegetation appropriate for erosive flows.  Carefully select proper trees and root barriers as needed.
Drainage	Place an area drain in vegetated feature, located to maximize travel distance of flow through landscaping, or allow for overflow water to sheet flow out of vegetated area to drainage system, as approved by local permitting agency.
<b>Pavement Draining to Porous Pavement</b>	
Impervious-Porous Ratio	2:1 maximum (see Appendix D)
Other	See design criteria for Porous Pavement Fact Sheet elsewhere in this chapter.
Sources: Ventura and Denver	



## References

- Adams, M.C., *Porous Asphalt pavement with recharge beds: 20 years & still working*. Stormwater. May/June 2003.
- Bay Area Stormwater Management Agencies Association, *Start at the Source - Design Guidance Manual for Stormwater Quality Protection*, 1999.
- City of Portland, *City of Portland Stormwater Management Manual*. Revision 3, September 1, 2004.
- City of Portland, *Sustainable Infrastructure Alternative Paving Materials Subcommittee Report*, October 3, 2003.
- Contra Costa Clean Water Program, Contra Costa, CA, *Stormwater C.3 Guidebook: Stormwater Quality Requirements for Development Applications*, March 2005.
- Paris N. and M. Chusid, *Coloring Pervious Pavement... because protecting the environment should be beautiful*, Dec/Jan 2006. [www.ConcreteDecor.net](http://www.ConcreteDecor.net)
- SMRC, *The Stormwater Manager's Resource Center. Fact Sheets*, accessed June 14, 2006. [www.stormwatercenter.net/Assorted%20Fact%20Sheets/Tool6\\_Stormwater\\_Practices/Infiltration%20Practice/Porous%20Pavement.htm](http://www.stormwatercenter.net/Assorted%20Fact%20Sheets/Tool6_Stormwater_Practices/Infiltration%20Practice/Porous%20Pavement.htm)
- Truckee Meadows Regional Storm Water Quality Management Program: *Draft Low Impact Development Handbook*, August 2005.
- United States Environmental Protection Agency, *National Menu of Best Management Practices for Storm Water Phase II*, 2002. <http://cfpub.epa.gov/npdes/stormwater/menuofbmps/index.cfm>
- University of Connecticut, *Nonpoint Education for Municipal Officials*. accessed May 26, 2006. <http://nemo.uconn.edu>
- Urban Drainage and Flood Control District, Denver, CO, *Urban Storm Drainage Criteria Manual Volume 3 – Best Management Practices*, September 1999 (Rev. October 2005).
- Virginia Department of Conservation and Recreation, *Virginia Stormwater Management Program Handbook*, 1999.

THIS PAGE INTENTIONALLY LEFT BLANK

# Disconnected Roof Drains

---

## Description

Roof drains can be disconnected from the storm drain system by directing the roof runoff across vegetation or into subsurface infiltration devices where it is filtered or infiltrates into the ground. The water may be directed across lawns, through dense groundcover, into devices such as a dispersal trench or infiltration well, if acceptable to the permitting agency. Roof runoff can also be directed into vegetated swales and bioretention planters for stormwater quality treatment (see fact sheets for these measures elsewhere in this chapter).

*Consult a geotechnical engineer about site suitability and other design considerations.*

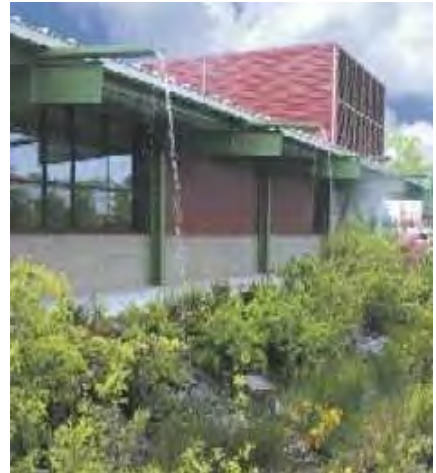

*Source: City of Portland*

## Siting Considerations

- Soils: Infiltration structures are generally suitable for Type A and B soils.
- Depth to groundwater: For infiltration structures, minimum vertical separation to groundwater table is 10 feet below bottom of facility.
- Setback: Infiltration structures must be min. 20 feet from buildings, min. 150 horizontal separation from drinking water wells (smaller setback maybe allowed with geotechnical engineer approval, verify with local permitting agency).
- Slope: up to 25%
- Vegetation: Sufficient vegetated area must be available for overland conveyance.

## Vector Considerations

- Potential for mosquitoes due to standing water in vegetated features will be greatly reduced or eliminated if the feature is properly designed, constructed, and maintained to ensure complete drainage.

## Advantages

- Takes advantage of existing/planned landscape areas; no additional space required.
- Can reduce size of downstream stormwater quality treatment measures by reducing the volume required to treat.
- Potential LEED Credits
  - Credit 6.1 – Stormwater Design – Quantity Control

### Limitations

- Plant materials in landscaped areas receiving the runoff should be designed to withstand occasional inundation.
- Subsurface infiltration devices may eventually clog with sediment, requiring costly reconstruction.
- Soil permeability may limit applicability of subsurface infiltration structures.

### Maintenance Recommendations

- Irrigate and maintain vegetated areas to maintain infiltration and filtering capacity.
- Periodically check for clogging of any subsurface pipes or infiltration systems and repair as needed.

## How Do Disconnected Roof Drains Work?

Disconnected roof drains effectively disconnect the rooftop from the local storm system, which helps reduce runoff and provides incidental pollutant removal as the water travels over and through the vegetation and soil. In this approach, roof runoff is directed to spread over a vegetated area (the surface conveyance zone), or into underground infiltration devices, if approved by the local permitting agency. Greater surface area and contact time within the surface conveyance zone promote greater runoff treatment efficiencies.

*Other Names:* Disconnected downspouts, disconnected roof leaders

## Planning and Siting Considerations

- Consult a geotechnical engineer about site suitability and other design considerations. The geotechnical report shall include information regarding proximity to hazardous spills or contaminated plumes within a 1000 feet radius of the project site using GeoTracker ([https://www.waterboards.ca.gov/gama/geotracker\\_gama.shtml](https://www.waterboards.ca.gov/gama/geotracker_gama.shtml) )
- Assess soil permeability to determine if infiltration option is viable for the type of system desired. Consult a geotechnical engineer if needed, particularly in areas adjacent to building foundations.
- Design buildings to take advantage of vegetated areas. Direct roof flow away from paved surfaces.
- Design site with a minimum of 2% positive slope away from building foundations.
- Maximize the length, and minimize the slope, of the surface conveyance zone. The land surrounding the downspout/emitter should be graded to spread and convey storm water (minimum 2 feet wide) and prevent concentration of flows.
- Integrate the disconnected roof drain system into the site landscaping plan.
- Consider using infiltration wells or dispersal trenches where the surface conveyance zone slope exceeds 25% and local permitting agency allows. Such devices must typically be located a minimum of 20 feet from any buildings, but verify with local permitting agency.

## Disconnected Roof Drains

- Use of dispersal trenches and infiltration wells is restricted on commercial and industrial projects depending on pollutant potential; check with local permitting agency.

## Variations

Four types of disconnected roof drain systems are discussed in this fact sheet: 1) splash block, 2) pop-up drainage emitter, and 3) dispersal trench and 4) infiltration well. Check with the local permitting agency to determine if all types are allowed and if they have any local specifications or details to add to, or replace, those shown here.

### Splash Block

Splash Blocks reduce the velocity and impact of water exiting the roof downspout and direct water to a pervious surface conveyance zone. Storm water traveling across the surface conveyance zone is filtered and infiltrated. Where the slope of the surface conveyance zone is greater than 8%, a gravel level spreader is required at the end of the splash block. A gravel spreader is a pocket of gravel that collects water and encourages sheet flow. The spreader may be covered with geotextile, soil and vegetation to fit with site landscaping.

For single family residential sites, the stormwater must flow across appropriate vegetation throughout the entire surface conveyance zone (from the downspout to the sidewalk). For commercial and multi-family sites, minimum travel distances across vegetation are specified based on contributing roof area (see Table DRD-1).



Source: Alameda Countywide  
Clean Water Program

*Table DRD-1. Surface Conveyance Zone for Splash Blocks and Pop-up Drainage Emitters:  
Commercial and Multi-Family Residential Areas*

Maximum Roof Size (sf)	Minimum Travel Distance Across Vegetation
3,500	21 feet
5,000	24 feet
7,500	28 feet
10,000	32 feet

## Disconnected Roof Drains

### Pop-up Drainage Emitter

*(Check with local permitting agency for any local specifications before using this information).*

Pop-up drainage emitters are appropriate when it is not possible to convey water directly from the downspout due to grading, paving or other site constraints. Pop-up Drainage Emitters are also useful in conveying storm water from backyard downspouts to front yard conveyance zones. Roof runoff is piped then released through a capped device that opens with water pressure. Yard drains may be used as component of the pop-up emitter system. For example, roof-top runoff directed to a back yard may be collected in a yard drain, then directed to a front yard pop-up emitter system.

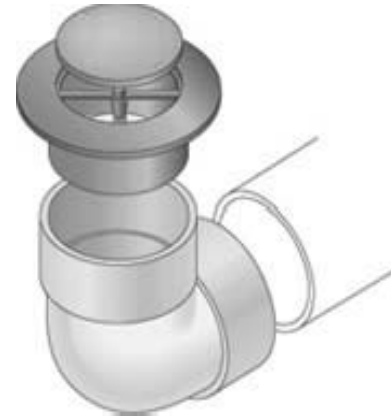

For single-family residential development, pop-up emitters must daylight no closer than five feet from the building with positive drainage away from building foundations and slabs for another five feet, where possible. The five feet limit is to allow for maximum travel distance across the yard.

### Dispersal Trench

*(Check with local permitting agency for any local specifications before using this information).*

A Dispersal Trench is appropriate for situations where the slope from the building does not meet the slope requirements or there is limited surface conveyance zone area available. The downspout may be piped directly to a Dispersal Trench through a perforated or slotted pipe that allows water to seep into the drain rock and surrounding soil. A maximum of 1750 square feet of roof area can be allowed to drain into one 8-foot long dispersal trench. These underground structures may be topped with geotextile fabric and 6 inches of soil for planting. See Figure DRD-1 for an example of the dispersal trench system design.

A debris collection point, or pretreatment sump, is required to prevent sedimentation and clogging of the dispersal trench. Once the pretreatment sump has filled with debris, it should cause a noticeable amount of overland flow bypassing the dispersal trench, which indicates that it is time to maintain the device.

The roof gutters should be fitted with mesh screens to prevent leaf litter and other debris from entering the system where there is tree cover. The expected growth of newly planted trees should be considered.

An overflow outlet should be provided on the downspout at the surface elevation to allow flow to bypass the system when either the infiltration trench or pretreatment sump are clogged or when hydrologic capacity is exceeded.

## Disconnected Roof Drains

To reduce the potential for costly maintenance and/or system reconstruction, it is strongly recommended that dispersal trenches be located in lawn areas (or other vegetated areas) and as close to the surface as possible.

*Other names:* Perforated Pipe System, French Drain

# Disconnected Roof Drains

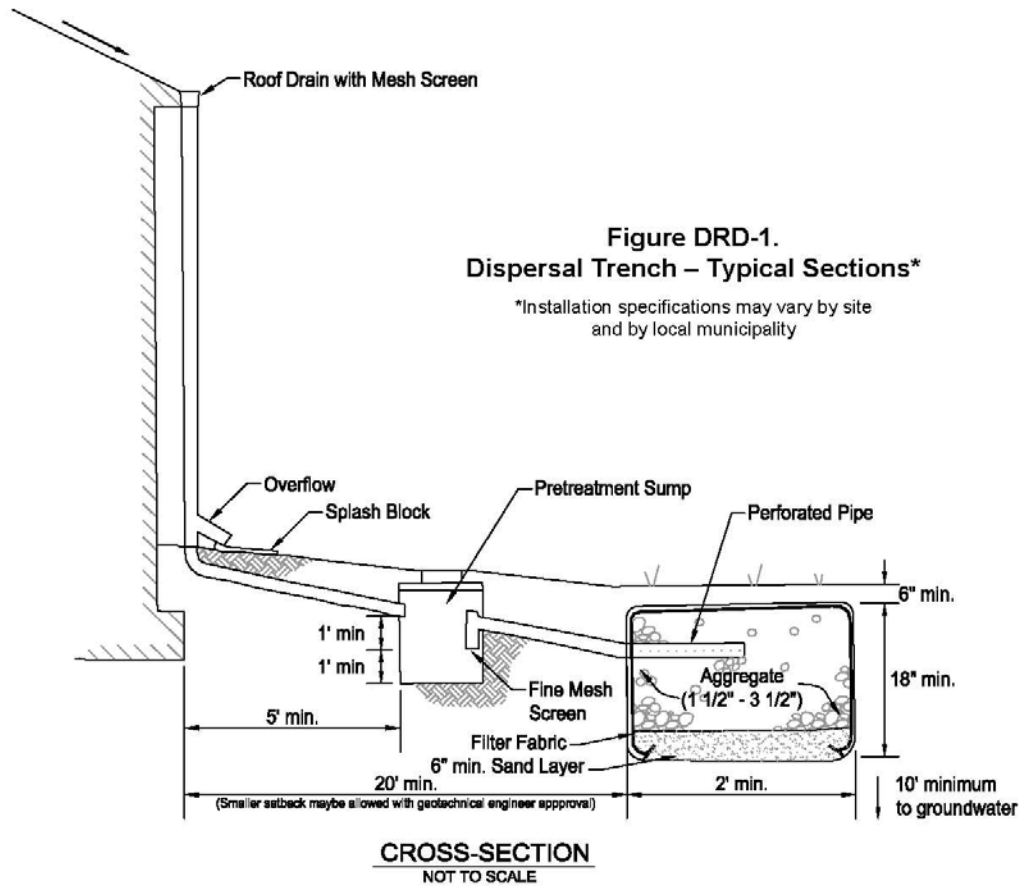
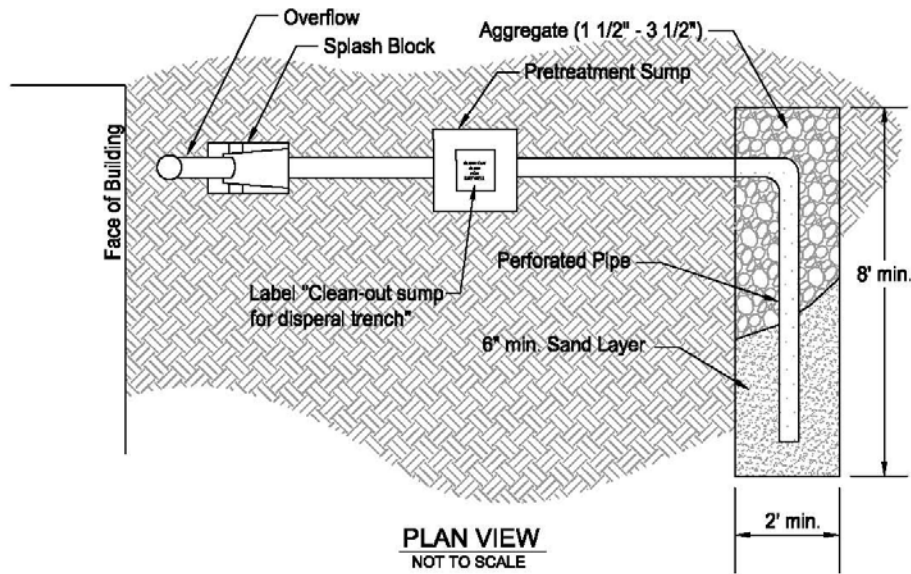

**Figure DRD-1. Dispersal Trench – Typical Sections\***

\*Installation specifications may vary by site and by local municipality

*Figure DRD-1. Dispersal Trench – Typical Sections*

Installation specifications may vary by site and by local municipality



### Infiltration Wells

*(Check with local permitting agency for any local specifications before using this information).*

Infiltration Wells are similar to Dispersal Trenches except that the dimensions maybe different. The infiltration well may be concrete or plastic (or other approved material), cylindrical or square, with perforations large enough to take full advantage of the infiltration capacity of the surrounding soil. Infiltration wells have a maximum depth of 4 feet.

All design requirements related to pretreatment sumps, gutter protection, and overflows are the same as those for Dispersal Trenches. See Figure DRD-2 for an example of the infiltration well design.

These underground structures may be topped with geotextile fabric and 6 inches (or more depending on approved specifications) of soil for planting.

The sizing and design requirements in this fact sheet are only applicable to infiltration wells with the sole purpose of disconnecting roof drains.



*Bilby Road, The City of Elk Grove*

### Design Criteria

Design criteria for disconnected roof drains and discharge variations are listed in Table DRD-2.

### Construction Considerations

#### Splash Block and Pop-up Drainage Emitter

- Site must be graded to prevent ponding of water at base of building.
- Splash blocks must be secured in place over compacted soil.
- Roof drainage conveyance areas must be protected from erosion during vegetation establishment period. Temporary measures such as erosion control blanketing may be used, however it may be necessary to bypass the stormwater around the surface conveyance zone during the stabilization period.

## Disconnected Roof Drains

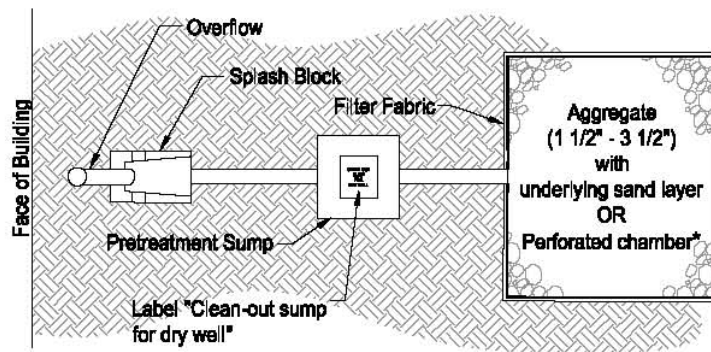

**PLAN VIEW**  
NOT TO SCALE

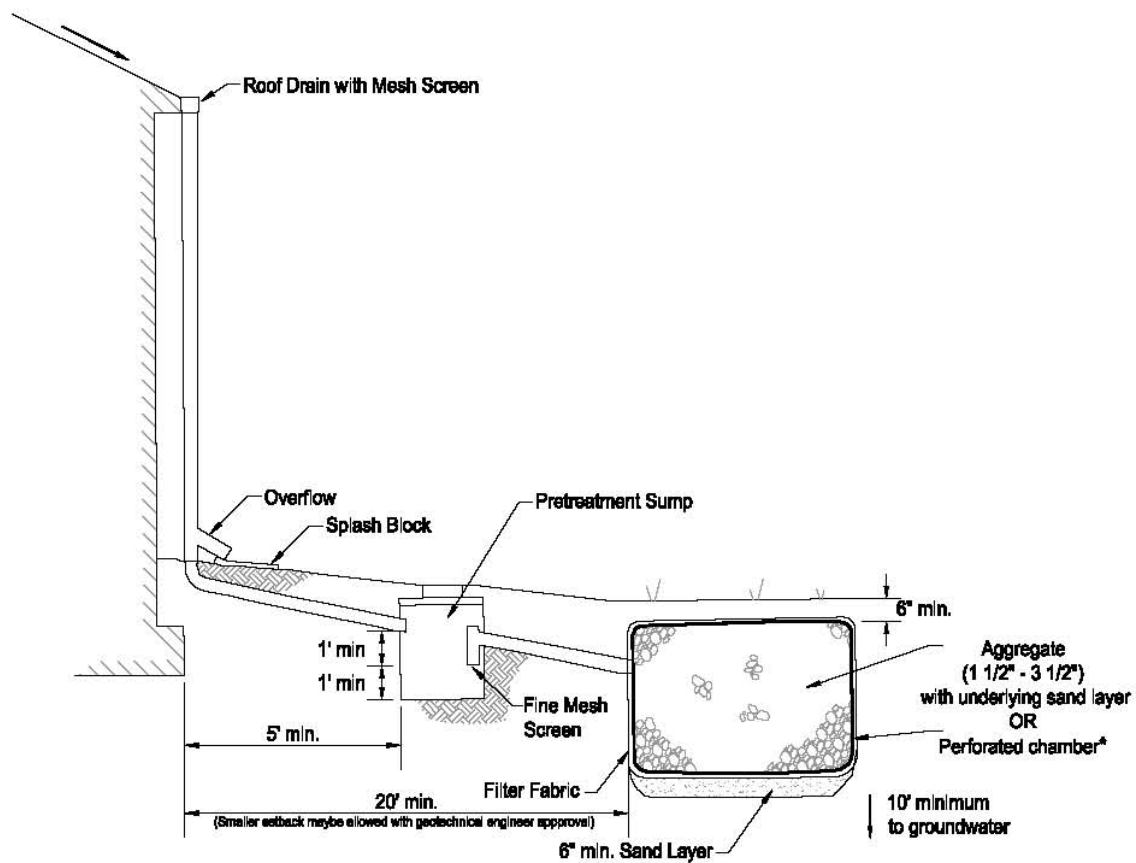

**CROSS-SECTION**  
NOT TO SCALE

\* Subject to approval of permitting agency. Manufacturer's specifications and additional restrictions apply (consult permitting agency).

*Figure DRD-2. Infiltration Well – Typical Sections*

*Installation specifications may vary by site and by local municipality*

### Dispersal Trench and Infiltration Well

- Do not allow soil below trench area to be compacted during construction.
- The floor of the trench/well must be level to allow for spreading of flow across the trench.
- To prevent sedimentation of the structure, the inlet pipe must be plugged until soil on the site is stabilized. To protect the structure *during* construction, provisions for sediment control must be included in the design.

## Long-term Maintenance Recommendations

Table DRD-3 presents inspection and maintenance recommendations for disconnected roof drains in general and two design variations related to disconnected roof drains (dispersal trench and infiltration well). The local permitting agencies require that the property owner be responsible for maintaining the features to ensure continued, long-term performance (refer to Appendix B). The pervious features should not be removed or replaced or all water quality benefits will be lost. In general, a maintenance agreement will not be required for this type of installation. However, developers are responsible for educating new homeowners that such devices are installed on their property and should be maintained following the recommendations provided in Table DRD-3. Where possible, such recommendations should be included in Covenants, Codes and Restrictions for new residential subdivisions.

*Table DRD-2. Disconnected Roof Drains Design Criteria*

Variation/Parameter	Criteria
<i>Splash Block/Pop-up Drainage Emitter</i>	
Surface	Minimum 2% positive slope away from building foundations for 4 feet minimum. Surface must be contoured to allow for sheet flow at least 5 feet wide. Must be planted with erosion resistant vegetation (turf or dense groundcover). Ground cover use limited to slopes less than 4%.
Splash Block	Must be at least 24 inches long, 2 inches deep and 10-12 inches wide where it meets the surface conveyance zone. Must weigh at least 10 pounds and be sloped away from building.
Spreader	Where slope more than 8%, spreader required at end of splash block; spreader must be drain rock, 24 inches long, 6 inches wide, and 8 inches deep, and level at surface. Gravel may be placed below surface and covered with geotextile fabric, 4 inches of soil and grass.
Emitter/pipe	Pipe must be at least 6 inches below the surface and a minimum of 4 inches in diameter (may not be suitable for large contributing roof areas). Emitter elevation must be lower than the finished grade of the base of the downspout and the yard drain (if used). Emitter must daylight no less than 5 feet from building (residential only).
Travel Distance	See Table DRD-1 and Appendix D.

## Disconnected Roof Drains

Variation/Parameter	Criteria
<i>Infiltration Systems: Dispersal Trench and Infiltration Well</i>	
Soils	Soil type extending 3 feet from bottom of facility must have infiltration rate between 0.5 inches per hour and 8 inches per hour. Soil may be amended to achieve infiltration rate.
Setback	Must be located a minimum of 20 feet from building. A smaller setback maybe allowed with geotechnical engineer approval.
Pretreatment Sump	Must be located a minimum of 5 feet from building. Must be labeled at surface “clean-out sump for dispersal trench or infiltration well.”
Overflow	Must be set on splash block.
Loading	Must demonstrate that the appropriate loading tolerance is achieved for proposed use of surface. Provide psi rating for structure/design.
Surface	Minimum 2% positive slope away from building foundations (4 feet minimum) (per Building Code).
Surface Label	Surface identification label may be required; check with the local permitting agency.
<i>Dispersal Trench Only</i>	
Configuration	Must be installed parallel to site contours; must be a minimum of 2 feet wide and 18 inches deep; maximum depth is 4 feet; must be a minimum of 8 feet long; must be lined with geotextile fabric (sides and top) and filled with drain rock.
Perforated Pipe	Must be a minimum of 6 inches below grade.
<i>Infiltration Well Only</i>	
Capacity	Must design a minimum 24 cubic feet of storage capacity for every 1750 square feet of contributing roof area for infiltration wells intended solely for disconnection of roof drains. Maximum depth is 4 feet.
Drain Rock	Must be filled with drain rock or use perforated chamber (with or without rock) upon approval of permitting agency.
Perforated Chamber (if allowed)	Perforated chambers must be designed and installed according to manufacturer’s specifications. Perforations in structure must allow for discharge of water at a rate higher than soil infiltration rate. Must be lined with geotextile fabric. Consult manufacturer’s specifications for additional design requirements.

Source: High Point Community Site Drainage Technical Standards. Seattle, Washington.

## Disconnected Roof Drains

*Table DRD-3. Inspection and Maintenance Recommendations for Dispersal Trenches and Infiltration Wells*

<i>Disconnected Roof Drains – General</i>	
Gutters	<ul style="list-style-type: none"> <li>▪ When cleaning gutters, repair wire mesh as needed to keep leaves and debris out of drain pipes.</li> </ul>
Overflow	<ul style="list-style-type: none"> <li>▪ Periodically inspect and clear overflow pipe.</li> </ul>
<i>Dispersal Trench and Infiltration Well</i>	
Surface and Vegetation Maintenance	<ul style="list-style-type: none"> <li>▪ Keep the surface clean and free of leaves, weeds, debris, and sediment, and do not replace or cover it with an impermeable paving surface.</li> <li>▪ Do not store loose material such as bark or sand over infiltration well or trench area; this can clog the infiltration facility.</li> <li>▪ Do not plant trees or shrubs over infiltration structures. Grass and plants (especially drought-tolerant varieties) are best.</li> <li>▪ Use integrated pesticide management techniques and minimize use of fertilizers, herbicides and insecticides in vegetated areas.</li> <li>▪ Remove grass clippings in grass areas over infiltration structures.</li> <li>▪ Reseed grasses when needed and keep healthy and dense enough to provide filtering while protecting underlying soils from erosion.</li> </ul>
Pretreatment Sump	<ul style="list-style-type: none"> <li>▪ Inspect sump monthly and after heavy rainfall and clean out accumulated sediment/debris as needed.</li> </ul>
Ponding Water/Mosquito Control	<ul style="list-style-type: none"> <li>▪ Check for and eliminate any ponding water that does not drain within 48 hours, since that provides an environment for insect larvae.</li> <li>▪ Standing water is usually an indication that the facility is clogged (the overflow and/or the sump needs to be cleaned and/or the device needs to be reconstructed).</li> </ul>
Manufacturer's Recommendations	<ul style="list-style-type: none"> <li>▪ For manufactured products, follow manufacturer's maintenance recommendations.</li> <li>▪ Make structural repairs when necessary to restore function.</li> </ul>
Replacement	<ul style="list-style-type: none"> <li>▪ Reconstruct or replace when it is no longer functioning properly. For planning purposes, estimated life expectancies are as follows: dispersal trench - 30 years, infiltration well – 30 years. (Source: City of Portland, Oregon)</li> </ul>

## References

- Bay Area Stormwater Management Agencies Association, *Start at the Source - Design Guidance Manual for Stormwater Quality Protection*, 1999.
- Center for Watershed Protection, New York State Department of Environmental Conservation, *New York State Stormwater Management Design Manual*, Albany, NY, October 2001.
- City of Portland, *City of Portland Stormwater Management Manual*. Revision 3, September 1, 2004.
- Contra Costa Clean Water Program. Contra Costa, CA, *Stormwater C.3 Guidebook: Stormwater Quality Requirements for Development Applications*, March 2005.
- *High Point Community Site Drainage Technical Standards*. Seattle, WA, June 2004.
- Shueler T., Swann C., Wright T, and S. Sprinkle, *Urban Subwatershed Restoration Manual No 8: Pollution Source Control Practices*. Version 1.0. Center for Watershed Protection. Ellicott City, MD. July 2004.
- SMRC, *The Stormwater Manager's Resource Center. Manual Builder*.  
[http://www.stormwatercenter.net/Manual\\_Builder/Credits/SITE/rooftop.htm](http://www.stormwatercenter.net/Manual_Builder/Credits/SITE/rooftop.htm)
- *Truckee Meadows Regional Storm Water Quality Management Program: Draft Low Impact Development Handbook*. August 2005.
- United States Environmental Protection Agency, *National Menu of Best Management Practices for Storm Water Phase II*, 2002.  
<http://cfpub.epa.gov/npdes/stormwater/menuofbmps/index.cfm>
- Virginia Department of Conservation and Recreation, *Virginia Stormwater Management Program Handbook*, 1999.

# Green Roof

---

## Description

A green roof is a multi-layered, vegetated rooftop system designed for filtering, absorbing, and retaining stormwater. Green roofs comprise lightweight growth media and a specialized mix of vegetation underlain by a root barrier, a drainage layer, and a waterproofing membrane that protects the building structure. A green roof captures stormwater within the pore space of the growth medium and then releases the water slowly via evaporation, transpiration and discharge to the roof drains. There are two types of green roofs – extensive (shallow growth media, simple vegetation) and intensive (deeper growth media, complex vegetation).



*Premier Automotive North American Headquarters, Irvine, California. Photo: Roofscapes, Inc.*

## Siting Considerations

- Space requirements: No additional space needed.
- Land use: Most appropriate for commercial or multi-family land uses, particularly infill development and multi-story buildings in dense urban areas, parking garage and retail/warehouse roofs.

## Vector Considerations

- Proper design, plant selection, construction, and maintenance of green roofs will greatly reduce or eliminate the potential for vector issues.
- Vector issues may arise due to standing water from leaky taps, air conditioning units, or other excess moisture sources on the roof. Also, rats, mice, and other vectors may be attracted to planted vegetation that produces nuts, fruit, or seeds.

## Advantages

- Requires no additional land.
- Improves outdoor air quality; aids in smog reduction.
- Decreases roof and runoff temperature (heat island effect).
- Provides insulation and lowers building cooling costs.

## Green Roof

- Protects underlying roof material from climatic extremes, ultraviolet light, and costly long-term damage.
- Can provide green space for building occupants to enjoy.
- Provides habitat for wildlife, particularly birds.
- Potential LEED Credits
  - Credit 6.1 – Stormwater Design – Quantity Control
  - Credit 6.2 – Stormwater Design – Quality Control

## Limitations

- Special structural design requirements to support green roof, irrigation needs and leak protection elements (due to roof irrigation) are likely to increase building costs.
- Erosion controls such as jute or cellulose netting and/or soil stabilizers will be required; additional controls such as cross-battens or steps may be required on sloped roofs.
- Not appropriate for wood frame construction.

## General Maintenance Requirements (Moderate to High)

- Irrigate to establish vegetation (first two years) and thereafter as needed.
- Routinely inspect and maintain the roof membrane, drainage layer flow paths and irrigation system.
- Repair eroded areas and replace vegetation as needed to maintain required cover.

---

*Green roofs are a proven technology and have been used/tested in Europe for over 40 years. They are gaining recognition in the U.S. for the environmental, economic, and social benefits they provide. There are now numerous applications in the San Francisco/San Jose Bay Area of California.*

---

## How Does a Green Roof Work?

Green roofs reduce runoff volume and peak flow through several mechanisms. When it rains, the green roof's foliage, growth medium, and root uptake zone retain a substantial portion of the stormwater that would otherwise flow from the roof to the storm drain system. The retention volume depends on many factors, including rainfall amount, depth and composition of the growth medium, and the type, diversity, and maturity of the vegetation. Some of the retained stormwater is released to the atmosphere via evaporation and transpiration (uptake by plants). The remainder slowly infiltrates through the growth medium to the roof underdrains and is discharged to the storm drain system with the volume and peak flow rate reduced.

Green roofs improve runoff water quality through a variety of biological, physical, and chemical processes within the plants and growth media. At the roof surface, airborne particulate matter (encompassing a range of organic and inorganic compounds) is intercepted and taken up by plant foliage. When it rains, stormwater (and associated air pollutants) is retained within and filtered through the growth media and root uptake zone. Contaminants sorb to clay and organic matter



within the growth media. Further pollutant removal is achieved by bioremediation and phytoremediation, carried out by bacteria and fungi present within the root systems. Pollutant removal increases as the vegetation and root systems mature.

*Other Names:* Ecoroof, green rooftop, nature roofs, vegetated roof covers

## Planning and Siting Considerations

- Involve the landscape architect, licensed structural engineer and mechanical engineer early in the design process with the project architect, since architectural roof style (pitch/slope, configuration), roof structural requirements, building heating/cooling needs, vegetation selection, and irrigation needs go hand in hand.
- Proper design and management of drainage is essential. Inadequate drainage may result in more load that the roof can sustain; plant mortality; degeneration of the growth medium; and/or vector control issues.
- Choose plants suitable for the local climate, rooftop microclimate and considering desired future irrigation. Check with the local permitting agency for recommended plants and planting guides for green roofs. Plants included in green roofs designed for stormwater management must be able to tolerate fluctuations between quick drainage and complete saturation of the soil. Limited studies have found the plants with greatest potential for stormwater management are grasses, herbaceous perennials, and mosses.
- Consider designing the green roof to serve as a greenspace amenity accessible to building tenants and/or the general public. This is particularly important quality of life benefit in dense, downtown urban areas where space for parks and natural areas is at a premium.



*Pedestrian Walkway on Stanford University Parking Garage Green Roof, Palo Alto, California.  
Design by Rana Creek Living Architecture.*

---

*Use the **Design Data Summary Sheet** (Table GR-3) to record design information for the permitting agency's review.*

---

## Design Criteria

Table GR-1 provides design criteria for green roofs; many parameters vary depending on the type of green roof (intensive or extensive). A Design Data Summary Sheet for green roofs (Table GR-3) is provided at the end of this fact sheet. Presently, the only widely-accepted, established standards for green roof construction are the comprehensive FLL standards developed in Germany. An American

## Green Roof

Standard Testing Methods (ASTM) task group is developing new standards for green roof installation; this fact sheet will be updated after the new standards are approved and published.

*Table GR-1. Green Roof Design Criteria*

Design Criteria	Extensive Green Roof	Intensive Green Roof
Design Volume	WQV, see Appendix D in this Design Manual for design requirements for volume-based control measures	Same
Design Drawdown time	12 hours	12 hours
Growth Media <sup>1</sup>	Typical depth: < 6 in.	Typical depth: 12+ in.
Vegetation	Low-growing, low water-use vegetation such as Sedum, herbs, grasses, and perennials	More complex gardens including the species listed for extensive green roofs, but also incorporating trees, shrubs
Load <sup>1</sup>	12-54 lbs/ft <sup>2</sup> average weight of saturated extensive roots is 17 lbs/ft <sup>2</sup> , comparable to gravel ballast in some conventional roofs	72+ lbs/ft <sup>2</sup>
Roof Slope	5:1 maximum	5:1 maximum
Access	Required for maintenance. Not generally designed for public access.	Required for maintenance. Public access often accommodated and encouraged.
Maintenance	Generally minimal once established.	Significant maintenance required due to greater loading and complex plantings.
Irrigation	Simple irrigation. If roof well-designed, needed only during plant establishment and droughts.	Complex irrigation.
Drainage	Simple drainage system.	Complex drainage system.
Source: Adapted from USEPA website on Green Roofs, <a href="http://www.epa.gov/hiri/strategies/greenroofs.html">www.epa.gov/hiri/strategies/greenroofs.html</a> Notes: 1. Range of values obtained from description of Roofmeadow® products: <a href="http://www.roofmeadow.com/assemblies.html">www.roofmeadow.com/assemblies.html</a>		

## Design Procedure

### General Design

Green roofs vary from small-scale designs using a single plant species to complex gardens with many types of plants. A typical configuration for multi-layer green roof systems is provided in Figure GR-1 and the design steps are briefly discussed below.

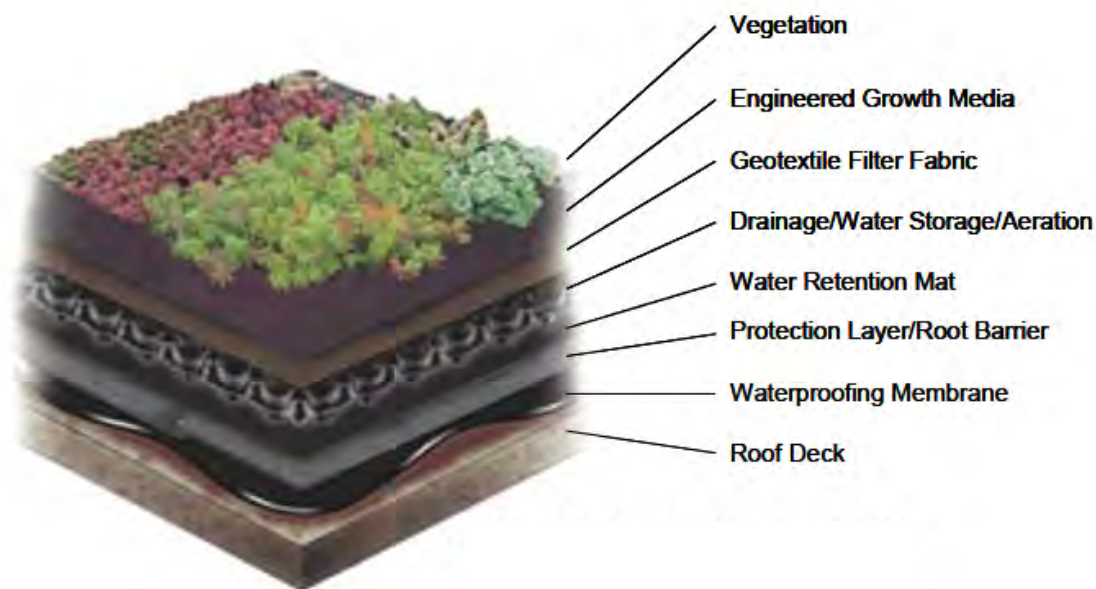

*Figure GR-1. Typical Green Roof Configuration*

Image source: American Hydrotech, Inc. ®, [www.hydrotechusa.com](http://www.hydrotechusa.com). Text detail added.

### Step 1 – Choose Vendor and Specialized Consultants

Green roofs are typically designed and installed by an established vendor. At a minimum, also consult:

- Structural engineer – to ensure the roof loading capacity is adequate
- Architect – to integrate green roof design with the building design, including planning for possible use by future building occupants
- Landscape architect – to design the planting areas, select vegetation and design the irrigation system
- Mechanical engineer – to calculate the heating and cooling implications of the green roof and to discuss how to integrate the green roof with rooftop mechanical equipment and drainage needs

### Step 2a – Calculate Water Quality Volume (WQV)

The growth media volume is a key criterion governing the sizing of the green roof. Provide sufficient volume within the pore space of the growth medium to contain the water quality design volume (WQV), which is determined using Appendix E information, based on a 12-hour drawdown period. Take into account the presence of established vegetation when determining the needed pore space. To calculate the volume of growth medium required to contain the WQV in the available pore space, use the following equation:

$$\text{Volume of growth medium} = \text{WQV} / \text{Porosity of growth media (with vegetation)}$$

### Step 2b – SAHM Modeling for Hydromodification Management (If applicable)

Upsize the green roof volume as necessary based upon modeling results if implementing as a hydromodification control.

### Step 3 – Select Green Roof Type

Decide whether to install an extensive or intensive green roof. Extensive green roofs, which have simple vegetation and shallow growth medium, are characterized by their low weight, low capital cost, and low maintenance, and can be retrofitted onto existing structures with little or no additional structural support. Intensive green roofs, which have complex vegetation and deeper growth medium, are characterized by their higher weight, capital cost, and higher maintenance requirements. They are more elaborate in design (sometimes even incorporating fountains and ponds), are typically intended for human use and interaction, and need to be engineered to conform to the load requirements. Characteristics of each green roof type are summarized in Table GR-1.

Make the decision whether or not to provide public access in this step, since this affects green roof type and load design (Step 4). If access will be provided, then, at a minimum, foot traffic must be accommodated with walkways or turf grass. (Turf grass must be irrigated and requires the deeper growth media of an intensive green roof.) Typically, green roofs with public access have a complex array of vegetation (i.e., are intensive green roofs) and may even have other garden features such as a fountain, ornamental pond, or patio/deck.

### Step 4 – Determine Required Structural Support and Green Roof Design

Design the structure to support the green roof, considering the saturated weight of the mature green roof system and the expected live load from human activity on the roof (e.g., maintenance staff, tenants, visitors). If a green roof is planned for a new building, the architects and structural engineers need to factor the green roof into the architectural and building design process. To retrofit an existing building, confer with an architect, structural engineer, and/or green roof consultant to ensure the proposed green roof can be supported – either as is or with additional support such as additional decking, roof trusses, joists, columns, and/or foundations, as indicated in Table GR-1.

If the roof will be accessible to the public, design the traffic flow paths and integrate decks, patios, or pavers into the design. Turf grass will stand up to regular foot traffic but requires an intensive

green roof system with deeper soil and mandatory irrigation. Alternatively, less intrusive, lightweight stepping stones or decomposed gravel walkways can be used to provide access and interpretation with extensive green roofs. Design roof entrance and exit routes to design standards to be safe and efficient for maintenance staff or the public.

## Step 5 – Select Component Layers

Green roof systems typically contain the following specialized component layers (see Figure GR-1):

- Waterproofing Membrane – Choose an adequate waterproof membrane that resists penetration by roots. The waterproofing component is essential to the long-term success of a green roof. Generally, a composite of several layers of protective materials is used. Materials used include modified asphalts (bitumens), synthetic rubber (EPDM), hypolan (CPSE), and reinforced PVC.
- Protection Layer/Root Barrier – The need for a separate root barrier (dense materials that inhibit root penetration) depends on the selected waterproof membrane. Modified asphalts usually require a root barrier, while synthetic rubber (EPDM) and reinforced PVC generally do not. Check with the manufacturer to determine if a root barrier is required for a particular product.
- Insulation/Air Barrier (optional) – If the thermal requirements of a building necessitate additional insulation, a layer of moisture-resistant insulation may be added.
- Water Retention Mat – If additional water retention is necessary to sustain the selected vegetation, a moisture retention mat may be used.
- Drainage/Water Storage/Aeration Layers – A green roof must safely drain runoff from the roof to an approved stormwater destination. Provide a drainage layer over the entire roof area to convey excess water to the building’s drainage system. Drainage layers usually consist of molded drainage channels and retention cups.
- Geotextile Filter Fabric – Include a geotextile filter fabric layer to keep the growth media out of the drainage layer.
- Engineered Growth Media – Green roof growth media differ from soil in that they generally comprise lightweight mineral material containing a minimum of organic matter. Use a growth medium that meets established FLL or ASTM guidelines for both water retention and drainage. Growth media need to remain viable for decades for both plant growth and water control. The growth medium used in green roofs should:
  - Not degrade or compress over time;
  - Be accompanied by third-party laboratory data confirming its essential properties; and
  - Be covered under warranty if it is defective or degrades within a certain timeframe.

## Green Roof

- Gravel Ballast (if needed) – Gravel ballast is sometimes placed along the roof perimeter and at air vents or other vertical elements. The need for ballast depends on operational and structural design issues. Ballast is sometimes used to provide maintenance access, especially to vertical elements requiring periodic maintenance. In some situations, a header or separation board may be placed between the gravel ballast and adjacent elements (e.g., growth media, drains). If a root barrier is used, it must extend under the gravel ballast and growth medium and up the side of the vertical elements.

### Step 6 – Select Vegetation

Hire experienced horticulturists and/or landscape/green roof contractors who understand the local climate as well as the restrictions of a rooftop environment to select, install and maintain vegetation for the green roof.

Typical green roof vegetation ranges from low-growing succulent plants (e.g., sedums) or groundcovers (characteristic of extensive green roofs) to an assortment of native grasses, shrubs, and trees (more typical of intensive green roofs). Select plants that:

- Are adapted to the local climate, considering seasonal temperature ranges and average rainfall, the harsh rooftop environment (exposure to direct sun, frost, wind) and desired irrigation
- Will tolerate short periods of inundation from storm events during the wet season (October 1 – April 30)
- Possess shallow root systems suited for the depth of the growth media
- Require little or no irrigation after establishment
- Are primarily non-deciduous to provide adequate foliage cover year-round and reduce erosion potential
- Have good regenerative qualities (i.e., perennial or self-sowing)
- Are low maintenance (i.e., no need for fertilizers, pesticides, or herbicides, little or no mowing or trimming)
- Have growth patterns allowing vegetation to thoroughly cover the soil (at least 90% surface area coverage should be achieved within 2 years).
- Are compatible with the aesthetic preferences of the owner and future building occupants who may utilize the roof as a green space

Plants of the genus *Sedum* (family Crassulaceae), which are low-growing succulents, are often used for green roofs because of their resistance to wind, frost, drought, and fire. A mix of *Sedum* and other succulent plants is recommended because they possess many of the recommended attributes. Herbs, forbs, grasses, and other low groundcovers may also be used but typically require more irrigation and maintenance. Although the use of native vegetation is preferred when possible, some natives may not thrive in the rooftop environment. Thus, a mix of approximately 80%

Sedum/succulent plants and 20% native plants generally recognized for their hardiness is recommended, particularly for extensive green roofs. (Velazquez, 2005)

### Step 7 – Determine Irrigation Needs

Determine irrigation needs based on the vegetation selected; at a minimum, temporary irrigation is recommended during the first two years of plant establishment. Potable water may be used in a permanent irrigation system, but consider using recycled, non-potable water, such as air conditioning condensate. Analyze any alternative water source to make sure it doesn't contain compounds harmful to the plants.

### Step 8 – Incorporate Fire Breaks

A Berlin study found that green roofs are more fire resistant than gravel roofs. The City of Portland's Fire Bureau recently converted a fire station conventional roof to a green roof. Green roofs may help slow the spread of fire to and from the building through the roof, particularly when the growth medium is saturated. Succulents such as *Sedum* offer good fire resistance due to their high water content. However, if the plants themselves are dry, they may present a fire hazard. The integration of vegetation-free "fire breaks" at regular intervals across the roof, at the roof perimeter, and around all roof protrusions is recommended. These breaks should be made of a non-combustible material such as crushed gravel, pebbles, or concrete pavers; be 12 to 36 inches wide; and be situated every 130 feet in all directions. Another option for fire prevention is a sprinkler irrigation system connected to the fire alarm. (Köhler 2004; Peck and Kuhn; Velazquez 2005)

## Construction Considerations

Consider hiring an environmental/green roof specialist to oversee the construction process.

- Throughout the construction process, protect green roof components, particularly the vegetation, until established.
- Prevent erosion by covering the growth media with mulch, jute/cellulose netting, or other approved protection methods prior to seeding or planting.
- Require consultants and installers to follow appropriate safety measures for working on industrial/commercial rooftops.

## Long-Term Maintenance

The local permitting agencies in the Sacramento area require execution of a maintenance agreement or permit with the property owner prior to final acceptance of a private development project that includes a green roof. Such agreements or permits will typically include requirements such as those outlined in Table GR-2. The property owner or his/her designee is responsible for compliance.

*Table GR-2. Inspection and Maintenance Recommendations for Green Roofs*

Activity	Schedule
<b>Irrigation</b>	
Irrigation can be accomplished by hand watering or automatic sprinkler systems (preferable). Follow the short and long-term watering regimes designed by the landscape designer, based on the selected plants and their water needs.	Irrigate plants regularly until they are established and thereafter as needed.
<b>Vegetation</b>	
Inspect and maintain vegetation to ensure at least 90% vegetative cover (visual guideline) at the end of the plant establishment period and thereafter. Replace dead plants as needed. Use fertilizers sparingly, if at all.	Inspect monthly during vegetation establishment period; thereafter, annually or as needed.
Remove fallen leaves and debris from deciduous plant foliage. Repair/replace damaged or dead vegetation to maintain required cover.	As needed.
Employ integrated pest management (IPM) practices to minimize or eliminate use of chemical pesticides and herbicides. Remove weeds manually whenever possible.	As needed. Remove weeds during growing season.
During drought conditions, apply mulch or shade cloth as needed to prevent excess solar damage and water loss.	As needed.
Mow grasses and remove clippings.	As needed.
<b>Component Layers</b>	
Inspect/maintain waterproof membrane for proper operation, waterproofing integrity, and structural stability.	2-3 times per year.
Inspect/maintain drainage layer flow paths for proper operation. Determine if drain pipes and inlets are in good condition and check drain inlets for obstructions. Clear inlet pipe of growth media, vegetation, debris or other materials. Identify and correct sources of obstructions.	At least twice per year during wet season, preferably during and after storms. Additional inspections after periods of heavy runoff are desirable.
Inspect growth medium for evidence of erosion from wind or water. If erosion channels are evident, stabilize with additional growth medium and plants.	2-3 times per year. Additional inspections after periods of heavy runoff are desirable.
<b>Other</b>	
Use spill prevention measures for rooftop mechanical systems when handling substances that can contaminate stormwater. Correct any identified releases of pollutants.	As needed.
Remove litter/trash from landscape area to prevent clogging of inlet drains and interference with plant growth.	As needed.



Activity	Schedule
Manage mosquitos by eliminating any observed standing water; use integrated pest management (IPM) techniques and seek advice of local vector control district.	Weekly during peak mosquito season (April – October); as needed thereafter.
Maintain green roof aesthetics. Repair any damage or vandalism and remove any trash or debris.	As needed.
Reconstruct or replace the control measure when it is no longer functioning properly.	See projected lifespan in Appendix B for informational purposes.
Source: Adapted from the City of Portland’s Stormwater Management Manual.	

## Helpful Links and Resources

- Ecoroofs Everywhere: [www.ecoroodseverywhere.org](http://www.ecoroodseverywhere.org)
- Greenroof Directory: [www.greenroofs.com](http://www.greenroofs.com)
- City of Portland, Oregon, Bureau of Environmental Services, Ecoroofs\*: [www.portlandonline.com/bes/index.cfm?c=34663](http://www.portlandonline.com/bes/index.cfm?c=34663) (includes the excellent publication “Portland Ecoroof Tours”)
- San Francisco Bay Area Stormwater Management Agencies Association (BASMAA), Site Design Guidebooks for Northern SF Bay Area, Alameda and Santa Clara Counties\*: [www.basmaa.org/documents/index.cfm?fuseaction=documents&doctypeID=3](http://www.basmaa.org/documents/index.cfm?fuseaction=documents&doctypeID=3)
- *Green Roof Plants: A Resource and Planting Guide*, Edmund C. Snodgrass and Lucie L. Snodgrass, 2006. Timber Press, Portland, OR.

\*These links contain project examples.

## References Used to Develop This Fact Sheet

- Bass, B., Modeling the Impact of Green Roofs on Toronto’s Urban Heat Island. Environment Canada, Green Roofs for Healthy Cities, 1999. [www.peck.ca/grhcc/research/overview.htm](http://www.peck.ca/grhcc/research/overview.htm)
- Cleaning & Maintenance Management, *Let Your Green Roof Thrive: Tips for managing increased pest pressures*, 2017, <https://www.cmmonline.com/articles/let-your-green-roof-thrive>
- Coffman, L.S., R. Goo and R. Frederick, *Low impact development an innovative alternative approach to stormwater management*. Proceedings of the 26th Annual Water Resources Planning and Management Conference. ASCE, Tempe, Arizona, 1999.
- Delston DIY Flat Roofing Company, Green Roofs, 1999. [www.delston.co.uk/greenroofs.htm](http://www.delston.co.uk/greenroofs.htm)

## Green Roof

- Dramstad, W. E., J.D. Olson, and R.T. Forman, *Landscape Ecology Principles in Landscape Architecture and Land-Use Planning*, Harvard University Graduate School of Design, Cambridge, 1996.
- EPA, *Green Roofs*, 2006. [www.epa.gov/heatisland/strategies/greenroofs.html](http://www.epa.gov/heatisland/strategies/greenroofs.html)
- Köhler, Manfred, *In Proceedings of the Greening Rooftops for Sustainable Communities Symposium*, Hosted by: Green Roofs for Healthy Cities and City of Chicago, Chicago, June 22-24, 2004.
- Lambrinos, John and Jordan, Marilyn, *Extensive Green Roofs: Horticultural Considerations for Stormwater Management*, April 2010. <https://www.pacifichorticulture.org/articles/extensive-green-roofs/>
- Miller, C, *Roofscapes, Inc., Green Technology for the Urban Environment*, 2006. [www.roofmeadow.com](http://www.roofmeadow.com)
- Moran, A., B. Hunt, and G. Jennings, *A North Carolina Field Study to Evaluate Greenroof Runoff Quantity, Runoff Quality, and Plant Growth*. Proceedings of the World Water & Environmental Resources Congress 2003 and Related Symposia. ASCE, 2003. doi 10.1061/40685(2003)335
- Ngan, Goya, *Green Roof Policies: Tools for Encouraging Sustainable Design*, 2004. [www.gnla.ca/library.htm](http://www.gnla.ca/library.htm)
- Peck, S.W. and C. Callaghan, *Greenbacks from Green Roofs: Forging a New Industry in Canada*, Prepared for: Canada Mortgage and Housing Corporation. Environmental Adaptation Research Group, Environment Canada, 1999.
- Peck, S. and Kuhn, M., *Design Guidelines for Greenroofs*, Prepared for the Canada Mortgage and Housing Corporation (CMHC) and the Ontario Association of Architects (OAA). [www.cmhcschl.gc.ca/en/inpr/bude/himu/coedar/loader.cfm?url=/commonspot/security/getfile.cfm&PageID=70146](http://www.cmhcschl.gc.ca/en/inpr/bude/himu/coedar/loader.cfm?url=/commonspot/security/getfile.cfm&PageID=70146)
- Portland, City of, *Stormwater Management Manual and various Green roof publications*, 2004.
- Scholz-Barth, K., *Green Roofs, Stormwater Management from the Top Down*, Environmental Design and Construction, 2001. [www.edcmag.com](http://www.edcmag.com)
- Velazquez, L., *Greenroofs.com: Exploring the Ecology of Organic Green Roof Architecture*, 2006. [www.greenroofs.com](http://www.greenroofs.com)
- Velazquez, L., *Organic Greenroof Architecture: Design Considerations and System Components*, Wiley Periodicals, Inc., Environmental Quality Management/Summer 2005.

Table GR-3. Design Data Summary Sheet for Green Roof

Designer: \_\_\_\_\_ Date: \_\_\_\_\_

Company: \_\_\_\_\_

Project: \_\_\_\_\_

Location: \_\_\_\_\_

---

1. Determine Design Water Quality Volume WQV = \_\_\_\_\_ ft<sup>3</sup>

---

2a. Determine growth medium volume based on porosity of growth media with vegetation.  
Volume of growth medium = WQV/Porosity V = \_\_\_\_\_ ft<sup>3</sup>

---

2b. Adjust Volume Up for Hydromodification Management (If Applicable) Based upon SAHM Modeling

Volume required based on SAHM modeling V = \_\_\_\_\_ ft<sup>3</sup>

SAHM Model Demonstrates Compliance with Flow Duration Standards (Yes or No) \_\_\_\_\_

---

3. Select green roof type  Extensive  Intensive

---

4. Determine Required Structural Support \_\_\_\_\_

---

5. Check that system includes all component layers

<input type="checkbox"/> Waterproofing Membrane	<input type="checkbox"/> Protection Layer/Root Barrier
<input type="checkbox"/> Insulation/Air Barrier (optional)	<input type="checkbox"/> Water Retention Mat
<input type="checkbox"/> Drainage/Water Storage/Aeration Layers	<input type="checkbox"/> Geotextile Filter Fabric
<input type="checkbox"/> Engineered Growth Media	<input type="checkbox"/> Gravel Ballast (if needed)

---

6. Select Vegetation and Describe

80% *Sedum* \_\_\_\_\_

---

20% Native species \_\_\_\_\_

---

7. Determine Irrigation Needs \_\_\_\_\_

---

8. Incorporate Vegetation-Free Zones or Fire Breaks \_\_\_\_\_

---

Notes: \_\_\_\_\_

---

THIS PAGE INTENTIONALLY LEFT BLANK

# Infiltration Basin

## Description

An infiltration basin is a shallow earthen basin constructed in naturally pervious soils (usually Type A or B) and designed for infiltrating stormwater. An infiltration basin functions by retaining runoff and allowing it to percolate into the underlying native soils and into the groundwater table over a specified drawdown period. The bottoms and side slopes of infiltration basins are typically vegetated with dryland grasses or irrigated turf grass.



Photo credit: Wisconsin DNR

## Siting Considerations

- Contributing drainage area: Up to 50 acres.
- Soil Infiltration Rate: 0.5-2.0 in/hr (permeability test required). Soils with higher infiltration rates require pretreatment device.
- Depth to groundwater: Minimum vertical separation to groundwater table is 10 ft from basin bottom
- Setback requirements: 150 ft from drinking water wells; 20 ft downslope and 100 ft upslope from foundations. Smaller setback maybe allowed with geotechnical engineer approval, verify with local permitting agency.
- Topography: Not appropriate on fill or steep slopes.

Pollutant Removal Effectiveness	
Sediment	High
Nutrients	High
Trash	High
Metals	High
Bacteria	High
Oil and Grease	High
Organics	High
Pyrethroids	High

*The following is a partial list of the most common target pollutants for the Sacramento area: copper, lead, mercury, pathogens, diazinon, and chlorpyrifos. For more complete information refer to:*

[http://www.waterboards.ca.gov/water\\_issues/programs/tmdl/integrated2010.shtml](http://www.waterboards.ca.gov/water_issues/programs/tmdl/integrated2010.shtml)

Source: CASQA California Stormwater BMP Handbook, January 2003

## Vector Considerations

- Potential for mosquitoes due to standing water will be greatly reduced or eliminated if the basin is properly designed, constructed, and operated to maintain its infiltration capacity and drawdown time.

### Advantages

- Reduces or eliminates stormwater discharge to surface waters during most storm events
- Reduces peak flows during small storm events.
- Can be incorporated into site landscape features or multi-use facilities such as parks or athletic fields.
- Potential LEED Credits
  - Credit 6.1 – Stormwater Design – Quantity Control
  - Credit 6.2 – Stormwater Design – Quality Control

### Limitations

- Not appropriate for areas with slowly permeable soils, high groundwater or existing groundwater contamination.
- Not appropriate for industrial sites or locations where spills may occur.
- Must be protected from high sediment loads. Once clogged with sediment, restoration of basin infiltration capacity may be difficult.

### General Maintenance Recommendations (Low to Moderate)

- Maintain vegetation as in any landscaped area.
- Periodically remove debris and sediment from basin floor.
- Repair/replace vegetation as necessary to maintain desired cover.
- Check and record drawdown time during and after major storm events to document infiltration rates.
- Remove sediment and/or scarify basin bottom to restore infiltration capacity when maximum drawdown time for WQV is exceeded.

## How Does an Infiltration Basin Work?

An infiltration basin is designed to retain the stormwater quality design volume (WQV) within a basin and to allow that volume to infiltrate into the native soil profile over the design drawdown period. Infiltrated water typically reaches and recharges the underlying groundwater. Treatment of the runoff occurs through a variety of natural mechanisms as the water flows through the soil profile. To ensure adequate treatment, the depth of unsaturated soil between the infiltration basin bottom and the seasonal maximum groundwater surface level should be at least 10 feet. See Figure IB-1 for a typical infiltration basin configuration.

*Other Names:* retention basin, percolation basin

---

*Do not confuse an Infiltration Basin with an Extended Dry Detention Basin, which is designed to infiltrate some runoff and release the rest, as described elsewhere in this chapter.*

---

## Planning and Siting Considerations

- Soil permeability, depth to groundwater, and design safety factors should be determined by a qualified geotechnical engineer or geologist to ensure that conditions conform to the criteria listed in Table IB-1. A soil permeability test will be required by permitting agency to confirm acceptable saturated permeability. Number of soil borings will depend on size of facility. Consult a geotechnical engineer and the permitting agency for guidance on soil permeability test details.
- The geotechnical report shall include information regarding proximity to hazardous spills or contaminated plumes within a 1000 feet radius of the project site using GeoTracker ([https://www.waterboards.ca.gov/gama/geotracker\\_gama.shtml](https://www.waterboards.ca.gov/gama/geotracker_gama.shtml) )
- Not suitable for areas with existing groundwater contamination.
- Integrate infiltration basins into open space buffers, undisturbed natural areas, and other landscape areas when possible. Avoid placing features in open space and wetland preserves where future maintenance of the water quality facility will be restricted or prohibited.
- Not suitable for active parkland/recreation use.
- Irrigation may be required to maintain vegetation on the slopes and bottom of the basin. If irrigation is needed, coordinate its design with that of the general landscape irrigation system for the project.
- Plan for setback requirements (see Table IB-1).

## Design Criteria

Design criteria for infiltration basins are listed in Table IB-1. Use the Design Data Summary Sheet provided at the end of this fact sheet (Table IB-3) to record design information for the permitting agency's review.

*Table IB-1. Infiltration Basin Design Criteria*

Design Parameter	Criteria	Notes
Contributing Drainage Area	≤ 50 acres	
Design Volume	WQV or as dictated greater by SAHM modeling (for projects with hydromodification requirement)	See Appendix E in this Design Manual
Soil Infiltration Rate	0.5-2.0 in/hr	To be confirmed by permeability test. <sup>1</sup> Higher permeability allowed if pretreatment provided.
Maximum Drawdown Time	48 hrs	Based on WQV (see Appendix E)
Minimum Groundwater Separation	10 ft	Between basin bottom and top of seasonally high groundwater table
Freeboard (minimum)	1 ft	

Design Parameter	Criteria	Notes
Setbacks	150 ft	From drinking water wells, tanks, fields, springs
	20 ft	Downslope from foundations
	100 ft	Upslope from foundations
Inlet/outlet erosion control	-	Use energy dissipator to reduce inlet/outlet velocity
Forebay settling basin volume/drain time	5-10%/45 minutes	Based on WQV
Embankment side slope (H:V)	≥ 4:1	Inside
	≥ 3:1	Outside (without retaining walls)
Maintenance access ramp slope (H:V)	10:1	Or flatter
Maintenance access ramp width	15 to 20 ft	Check with permitting agency for their minimum width. Pave approach with concrete or porous pavement materials, subject to approval of permitting agency.
Relief underdrain pipe diameter	4 inches	Perforated plastic pipe
Vegetation	-	Side slopes and bottom (may require irrigation)

<sup>1</sup> Consult with geotechnical engineer and permitting agency for permeability test details.

## Design Procedure

### Step 1a – Calculate Water Quality Volume (WQV)

Using the Appendix E in this Design Manual, determine the contributing drainage area and stormwater quality design volume (WQV) for 48-hour drawdown.

---

Use the **Design Data Summary Sheet** (Table IB-3) to record design information for the permitting agency's review.

---

### Step 1b – SAHM Modeling for Hydromodification Management (If applicable)

Upsize the infiltration basin volume as necessary based upon modeling results if implementing as a hydromodification control. Maintain depth so as to adhere with 48-hour maximum drawdown for WQV.

### Step 2 – Calculate Design Depth of Water Surge in Infiltration Basin ( $D_{max}$ )

$$D_{max} = \frac{t_{max} \times I}{12 \times s}$$

Where:

$t_{max}$  = Maximum drawdown time = 48 hrs

I = Site infiltration rate (soil permeability) (in/hr)

s = Safety factor



In the formula for maximum allowable depth, the safety factor accounts for the variability in soil permeability at the site and the relative uncertainty in the infiltration rate measurements. The more variable the soil conditions and the less certain the infiltration rate, the higher the safety factor should be. Safety factors typically range between two (2) and ten (10) and should be determined by a qualified geotechnical engineer or geologist based on field measurements of saturated vertical permeability at the proposed site. Note that soils with permeability greater than two (2) inches per hour may be used if full pretreatment is provided using one of the approved treatment controls from this manual.

### Step 3 – Calculate Minimum Surface Area of Infiltration Basin Bottom ( $A_{\min}$ )

$$A_{\min} = WQV/D_{\max}$$

Where:

$A_{\min}$  = minimum area required (ft<sup>2</sup>)

$D_{\max}$  = maximum allowable depth (ft)

### Step 4 – Design Forebay Settling Basin

The forebay provides a zone for removal of coarse sediment by sedimentation. Design the forebay volume to be five (5) to ten (10) percent of the WQV. Separate the forebay from the basin by a berm or similar feature. Provide an outlet pipe connecting the bottom of the forebay and the basin and size it to allow the forebay volume to drain within 45 minutes.

### Step 5 – Design Embankments

Interior slopes (H:V) should be no steeper than 4:1 and exterior slopes no steeper than 3:1. Flatter slopes are preferable.

### Step 6 – Design Maintenance Access

Provide for all-weather access for maintenance vehicles to the bottom and outlet works. Maximum grades of access ramps should be ten (10) percent and minimum width will vary according to local permitting agency requirements, but usually between 15-20 feet. Pave ramps with concrete that is colored to blend with surroundings.



*Florin Mall Dr. The City of Sacramento*

### Step 7 – Design Security Fencing

To protect habitat and for safety reasons, provide aesthetic security fencing approved by the permitting agency around the infiltration basin, except when specifically waived by the permitting agency.

### Step 8 – Design Bypass

Provide for bypass or overflow of runoff volumes in excess of the WQV. Provide stabilized spillway or overflow structures, as applicable (see Figure IB-1).

### Step 9 – Design Relief Drain

Provide 4-inch diameter perforated plastic relief underdrain with a valved outlet to allow removal of standing water in the event of loss of soil infiltration capacity. Cutoff collars are recommended along drain pipes running under the embankment at 10 to 20 feet intervals to prevent the water from piping through the fill. The portion of the relief drain that is under the embankment should not be perforated.

### Step 10 – Select Vegetation

Plant basin bottoms, berms, and side slopes with native grasses or with irrigated turf. Vegetation provides erosion protection and filters sediment out of the runoff. Shrubs and trees may also be incorporated where appropriate.

### Step 11 – Design irrigation system

Provide an irrigation system to maintain viability of vegetation (short-term establishment and long-term needs). Refer to the Efficient Irrigation fact sheet (EI-1) at the end of Chapter 4.

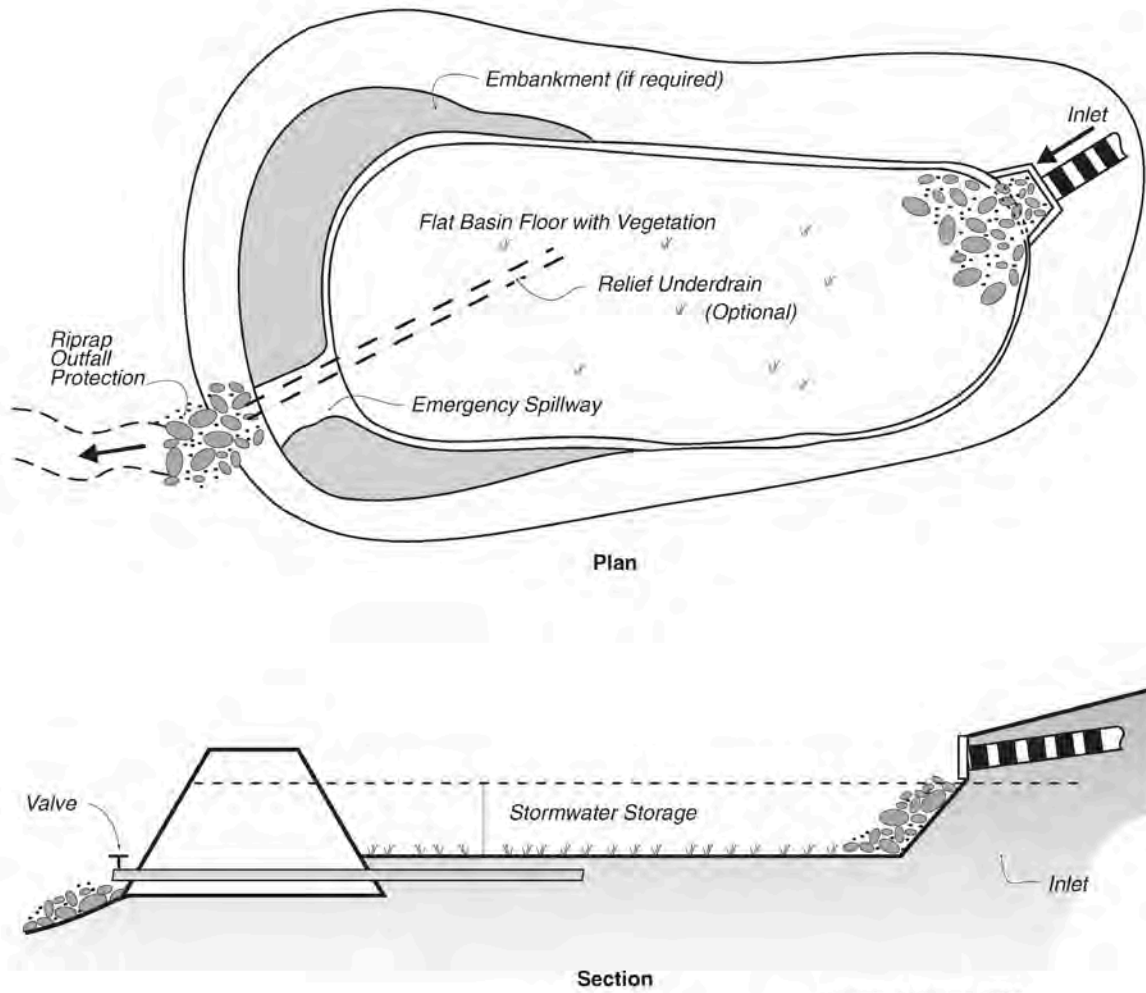

Source: Schueler, 1987

Figure IB-1. Infiltration Basin

## Construction Considerations

- If possible, stabilize the entire contributing drainage area to the infiltration basin before construction begins. If this is not possible, divert flow around the basin to protect it from sediment loads during construction. If sediment does enter the facility during construction, the contractor will be required to remove soil from the basin floor after the entire site has been stabilized, to the satisfaction of the permitting agency inspector.
- Construct basin using equipment with extra wide, low-pressure tires. Prevent construction traffic from entering basin.
- Ensure that final grading produces a level basin bottom without low spots or depressions.
- After final grading, deep till the basin bottom.
- Once construction is complete, stabilize the entire contributing drainage area to the basin and the vegetation within the basin itself, before allowing runoff to enter the infiltration facility.
- Divert runoff (other than necessary irrigation) during the period of basin vegetation establishment.
- Inspect frequently during vegetation establishment, and repair, seed, or re-plant damaged areas immediately.
- Provide cleanout stakes in the forebay and main basin to facilitate inspection and maintenance.
- Do not plant trees on compacted embankment.

## Long-term Maintenance

The local permitting agencies in the Sacramento area require execution of a maintenance agreement or permit with the property owner for projects including an infiltration basin. Check with the local permitting agency about the timing for execution of the agreement. Such agreements will typically include requirements such as those outlined in Table IB-2. The property owner or his/her designee will be responsible for compliance. See Appendix B for additional information about maintenance requirements and sample agreement language.

Table IB-2. Inspection and Maintenance Recommendations for Infiltration Basins

Activity	Schedule
Monitor infiltration rate in basin after storm events by recording the drop-in water depth versus time using a calibrated rod or staff gauge.	Several times during first year. Thereafter at the beginning and end of the wet season. Additional monitoring after periods of heavy runoff is recommended.
If drawdown time is observed to have increased significantly over the design drawdown time, clean, re-grade, and till basin bottom to restore infiltrative capacity. This maintenance activity is expensive and the need for it can be minimized by preventing upstream erosion.	As needed.
Inspect basin to identify potential problems such as erosion of the basin side slopes and invert, standing water, trash and debris, and sediment accumulation.	At beginning and end of the wet season. Additional inspections after periods of heavy runoff are desirable.
If erosion is occurring within the basin, stabilize with erosion control mulch or mat and seed or re-vegetate immediately.	As needed.
Monitor health of vegetation and replace as needed.	Routinely monitor vegetation.
Trim vegetation to prevent the establishment of woody vegetation and for aesthetic and vector control reasons.	At the beginning and end of the wet season.
Remove litter and debris from infiltration basin area.	As needed.
Remove accumulated sediment and re-grade when the accumulated sediment volume exceeds ten (10) percent of the basin volume. Note: scarification or other activities creating disturbance should only be performed when there are actual signs of clogging, rather than on a routine basis.	As required for both forebay and basin.
Reconstruct or replace the control measure when it is no longer functioning properly.	See projected lifespan in Appendix B for informational purposes.
Prune trees (if applicable).	Every 3-5 years.

Table IB-3. Design Data Summary Sheet for Infiltration Basin

**Designer:** \_\_\_\_\_ **Date:** \_\_\_\_\_  
**Company:** \_\_\_\_\_  
**Project:** \_\_\_\_\_  
**Location:** \_\_\_\_\_

**1a. Determine Design Water Quality Volume**

a. Contributing drainage area Area = \_\_\_\_\_ ft<sup>2</sup>  
 b. Water Quality Volume WQV = \_\_\_\_\_ ft<sup>3</sup>

**1b. Adjust Volume Up for Hydromodification Management (If Applicable) Based upon SAHM Modeling**

a. Water Quality Volume based on SAHM modeling V = \_\_\_\_\_ ft<sup>3</sup>  
 b. SAHM Model Demonstrates Compliance with Flow Duration Standards (Yes or No) \_\_\_\_\_

**2. Determine Maximum Allowable Depth ( $D_{max} \leq 10$  ft)**

a. Maximum drawdown time (t=48 hours) t = 48 hrs  
 b. Site infiltration rate (I) I = \_\_\_\_\_ in/hr  
 c. Safety factor (s) s = \_\_\_\_\_  
 d.  $D_{max} = \frac{t_{max} \times I}{12 \times s}$   $D_{max} =$  \_\_\_\_\_ ft

**3. Determine Minimum Allowable Basin Bottom Area**  
( $A_{min} = WQV/D_{max}$ )

$A_{min} =$  \_\_\_\_\_ ft<sup>2</sup>

**4. Forebay Volume (VFB)**

VFB = \_\_\_\_\_ ft<sup>3</sup>

**5. Bypass/Outlet Control Structure (check type)**

Overflow Structure                       Spillway

**6. Vegetation (check type used or describe "other")**

Native grasses                       Irrigated turf grass  
 Trees/Other: \_\_\_\_\_

Notes:

\_\_\_\_\_

\_\_\_\_\_

# Infiltration Trench

## Description

An infiltration trench is a long, narrow trench constructed in naturally pervious soils (types A or B) and filled with gravel (and sand if desired). Runoff is stored in the trench until it infiltrates into the soil profile over a specified drawdown period. Overflow drains are often provided to allow drainage if the infiltration trench becomes clogged. Infiltration vaults and infiltration leach fields are subsurface variations of the infiltration trench concept; runoff is distributed to the upper zone of a subsurface gravel bed by means of perforated pipes.



Photo credit: CASQA, 2003

## Siting Considerations

- Contributing Drainage area: Up to 5 acres. Contributing areas should have a low potential for erosion.
- Soil Infiltration Rate: 0.5-2.0 in/hr (permeability test required). Soils with higher permeability will require pretreatment device.
- Depth to groundwater: Minimum vertical separation to groundwater table is 10 ft from trench bottom
- Setback requirements: 150 ft from drinking water wells; 20 ft downslope and 100 ft upslope from foundations. Smaller setback maybe allowed with geotechnical engineer approval, verify with local permitting agency.
- Maximum contributing area slope: 5%, maximum downstream slope: 20%

### Pollutant Removal Effectiveness

Sediment	High
Nutrients	High
Trash	High
Metals	High
Bacteria	High
Oil and Grease	High
Organics	High
Pyrethroids	High

The following is a partial list of the most common target pollutants for the Sacramento area: copper, lead, mercury, pathogens, diazinon, and chlorpyrifos. For more complete information refer to:

[http://www.waterboards.ca.gov/water\\_issues/programs/tmdl/integrated2010.shtml](http://www.waterboards.ca.gov/water_issues/programs/tmdl/integrated2010.shtml)

Source: CASQA California Stormwater BMP Handbook, January 2003

### Vector Considerations

- Potential for mosquitoes due to standing water will be greatly reduced or eliminated if the trench is properly designed, constructed, and operated to maintain its infiltration capacity and drawdown time.

### Advantages

- Reduces or eliminates stormwater discharge to surface waters during most storm events.
- Reduces peak flows during small storm events.
- Can be incorporated into site landscaping.
- Potential LEED Credits
  - Credit 6.1 – Stormwater Design – Quantity Control
  - Credit 6.2 – Stormwater Design – Quality Control

### Limitations

- Not appropriate for areas with slowly permeable soil or high groundwater.
- Must be protected from high sediment loads; difficult to restore functionality when clogged.
- Not appropriate for industrial sites or locations where spills may occur.

### General Maintenance Recommendations (Low to Moderate)

- Repair/replace vegetation buffer as necessary to maintain full cover and prevent erosion.
- Periodically remove debris from trench surface.
- Check and record infiltration rate during and after major storm events to document infiltration rates.
- Repair or replace trench material to restore infiltration capacity when infiltration rate falls below design rate.

---

#### **Prevent Clogging!**

*Infiltration trenches need to be protected from sediment loads to prevent clogging; a grass buffer is required. If sediment deposition significantly reduces soil infiltration rates, the cost of restoring the trench can be high.*

---

## How Does an Infiltration Trench Work?

An infiltration trench is designed to retain the stormwater quality design volume (or WQV) in the trench and allow that volume to infiltrate into the native soil profile over the design drawdown period. Infiltrated water typically reaches and can recharge the underlying groundwater. Treatment of the runoff occurs through a variety of natural mechanisms as the water flows through the trench media and the soil profile. To ensure adequate treatment and protect groundwater, the depth of unsaturated soil between the trench bottom and the highest seasonal groundwater surface level should be at least 10 feet. See Figure IT-1 for a typical infiltration trench configuration.

Infiltration vaults (Figure IT-2) and infiltration leach fields (Figure IT-3) are similar to infiltration trenches except they are entirely below ground; runoff is conveyed to the upper zone of the gravel bed media via perforated pipes.



Other Names: Percolation trench

## Planning and Siting Considerations

- Conduct an on-site permeability test to confirm suitable infiltration rate prior to beginning design. At least one soil boring in proposed trench location is recommended; consult with a geotechnical engineer for guidance on soil permeability test details. Local permitting agency will require results before accepting design.
- The geotechnical report shall include information regarding proximity to hazardous spills or contaminated plumes within a 1000 feet radius of the project site using GeoTracker ([https://www.waterboards.ca.gov/gama/geotracker\\_gama.shtml](https://www.waterboards.ca.gov/gama/geotracker_gama.shtml) )
- Not suitable for areas with existing groundwater contamination.
- Integrate infiltration trenches into open space buffers, undisturbed natural areas, and other landscape areas when possible.
- Plan for setback requirements as listed in Table IT-1.
- Do not locate infiltration trenches under tree drip lines.
- Install a pretreatment grass buffer strip to filter out sediment and protect the trench from high sediment loads (see Figure IT-1).

## Design Criteria

Design criteria for infiltration trenches are listed in Table IT-1. Use the Design Data Summary Sheet provided at the end of this fact sheet (Table IT-3) to record design information for the permitting agency's review.

*Table IT-1. Infiltration Trench Design Criteria*

Design Parameter	Criteria	Notes
Contributing Drainage Area	≤ 5 acres	
Design Volume	WQV or as dictated greater by SAHM modeling (for projects with hydromodification requirement)	See Appendix E in this Design Manual
Maximum Drawdown Time for WQV	48 hrs	Based on WQV
Soil Infiltration Rate	0.5-2 in/hr	(soil permeability test required)
Minimum Groundwater Separation	10 ft	Between trench bottom and top of seasonally high groundwater table
Maximum Trench Surcharge Depth ( $D_{max}$ )	10 ft	
Setbacks	150 ft	From drinking water wells, tanks, fields, springs

Design Parameter	Criteria	Notes
	20 ft 100 ft -	Downslope from foundations Upslope from foundations Do not locate under tree drip-lines
Trench media material size/type	3 in. diameter	Washed gravel 6-12 inches deep sand (if desired)
Trench lining material	-	Geotextile fabric prevents clogging
Observation well size	4-6 in	Perforated PVC pipe with removable cap
Pretreatment grass buffer strip length/slope	10 ft/4%	Minimum length/maximum slope in flow direction

## Design Procedure

### Step 1a – Calculate Water Quality Volume (WQV)

Using the Appendix E in this Design Manual, determine the contributing drainage area and stormwater quality design volume (WQV) for 48-hour drawdown.

---

Use the **Design Data Summary Sheet** (Table IT-3) to record design information for the permitting agency’s review.

---

### Step 1b – SAHM Modeling for Hydromodification Management (If applicable)

Upsize the infiltration trench volume as necessary based upon modeling results if implementing as a hydromodification control. Maintain depth so as to adhere with 48-hour maximum drawdown for WQV.

### Step 2 – Calculate Design Depth of Water Surge in Infiltration Trench ( $D_{max}$ )

Maximum depth should not exceed ten (10) feet.

$$D_{max} = \frac{t_{max} \times I}{12 \times s \times P}$$

Where:

$t_{max}$  = Maximum drawdown time = 48 hrs

I = Site infiltration rate (soil permeability) (in/hr)

s = Safety factor

P = Porosity of infiltration trench gravel material (use 0.30)

In the formula for maximum allowable depth, the safety factor accounts for the variability in soil permeability at the site and the relative uncertainty in the infiltration rate measurements. The more variable the soil conditions and the less certain the infiltration rate, the higher the safety factor should be. Safety factors typically range between two (2) and ten (10) and should be determined by a

qualified geotechnical engineer or geologist based on field measurements of saturated vertical permeability at the proposed site. Note that soils with permeability greater than two (2) inches per hour may be used if full pretreatment is provided using one of the approved treatment controls from this manual (e.g., vegetated filter strip, vegetated swale).

### Step 3 – Calculate Minimum Surface Area of Infiltration Trench Bottom ( $A_{\min}$ )

$$A_{\min} = WQV/D_{\max}$$

Where:

$A_{\min}$  = minimum area required (ft<sup>2</sup>)

$D_{\max}$  = maximum allowable depth (ft)

### Step 4 – Design Observation Well

Provide a vertical section of perforated PVC pipe, four (4) to six (6) inches in diameter, installed flush with the top of the infiltration trench on a PVC footplate and with a locking, removable cap. The observation well is needed to monitor the infiltration rate in the infiltration trench and is useful for marking the location of the trench.

### Step 5 – Design Bypass

Provide for bypass or overflow of runoff volumes in excess of the WQV by means of a screened overflow pipe connected to the downstream storm drain system or a grated overflow outlet.

## Construction Considerations

- If possible, stabilize the entire contributing drainage area to the infiltration trench before construction begins. If this is not possible, divert flow around the trench site to protect it from sediment loads during construction.
- Once construction is complete, stabilize the entire contributing drainage area to the trench before allowing runoff to enter the trench facility.
- Install filter fabric on sides, bottom, and one foot below the surface of the trench (see Figure IT-1). Provide generous overlap at all seams.
- Store excavated material at least 10 feet from the trench to avoid backsliding and cave-ins.
- Place clean, washed 1-3 inch gravel in the excavated trench in lifts and lightly compact it with a plate compactor. Using unwashed gravel can result in clogging.



*Valley-Hi Library, The City of Sacramento*

## Long-term Maintenance

The local permitting agencies in the Sacramento area will require execution of a maintenance agreement or permit with the property owner for projects including an infiltration trench. Check with the local permitting agency about the timing for execution of the agreement. Such agreements will typically include requirements such as those outlined in Table IT-2. The property owner or his/her designee will be responsible for compliance. See Appendix B for additional information about maintenance requirements and sample agreement language.

*Table IT-2. Inspection and Maintenance Recommendations for Infiltration Trenches*

Activity	Schedule
Monitor the infiltration rate in the trench during and after storms by recording the drop-in water depth versus time using a calibrated rod or staff gauge.	Several times during first year then near the beginning and end of each wet season. Additional monitoring after periods of heavy runoff is desirable.
Clean the trench when the infiltration rate decreases significantly over the design rate. To clean it, remove the top layer of gravel and clogged filter fabric, install a new layer of filter fabric, wash the removed gravel, and place the washed gravel back into the trench. This maintenance activity is expensive and can be avoided by preventing upstream erosion and maintaining the pretreatment buffer strip.	As required.
Inspect grass buffer strip to identify potential channelization and erosion problems.	At beginning and end of the wet season. Additional inspections after periods of heavy runoff are desirable.
If channels are forming or erosion is occurring within the grass buffer strip, add soil as needed and stabilize with erosion control mulch or mat and re-seed or re-vegetate immediately. See the Vegetated Filter Strip fact sheet elsewhere in this chapter for more information.	As needed.
Inspect trench to identify potential problems such as standing water, trash and debris, and sediment accumulation.	At beginning and end of the wet season. Additional inspections after periods of heavy runoff are desirable.
Remove pioneer trees that sprout in the trench vicinity so that roots don't puncture the filter fabric, allowing sediment to enter the trench.	As needed.
Trim adjacent trees so the canopy doesn't extend over the trench surface.	As needed
Remove litter and debris from trench area.	As needed.
Reconstruct or replace the control measure when it is no longer functioning properly.	See projected lifespan in Appendix B for informational purposes.

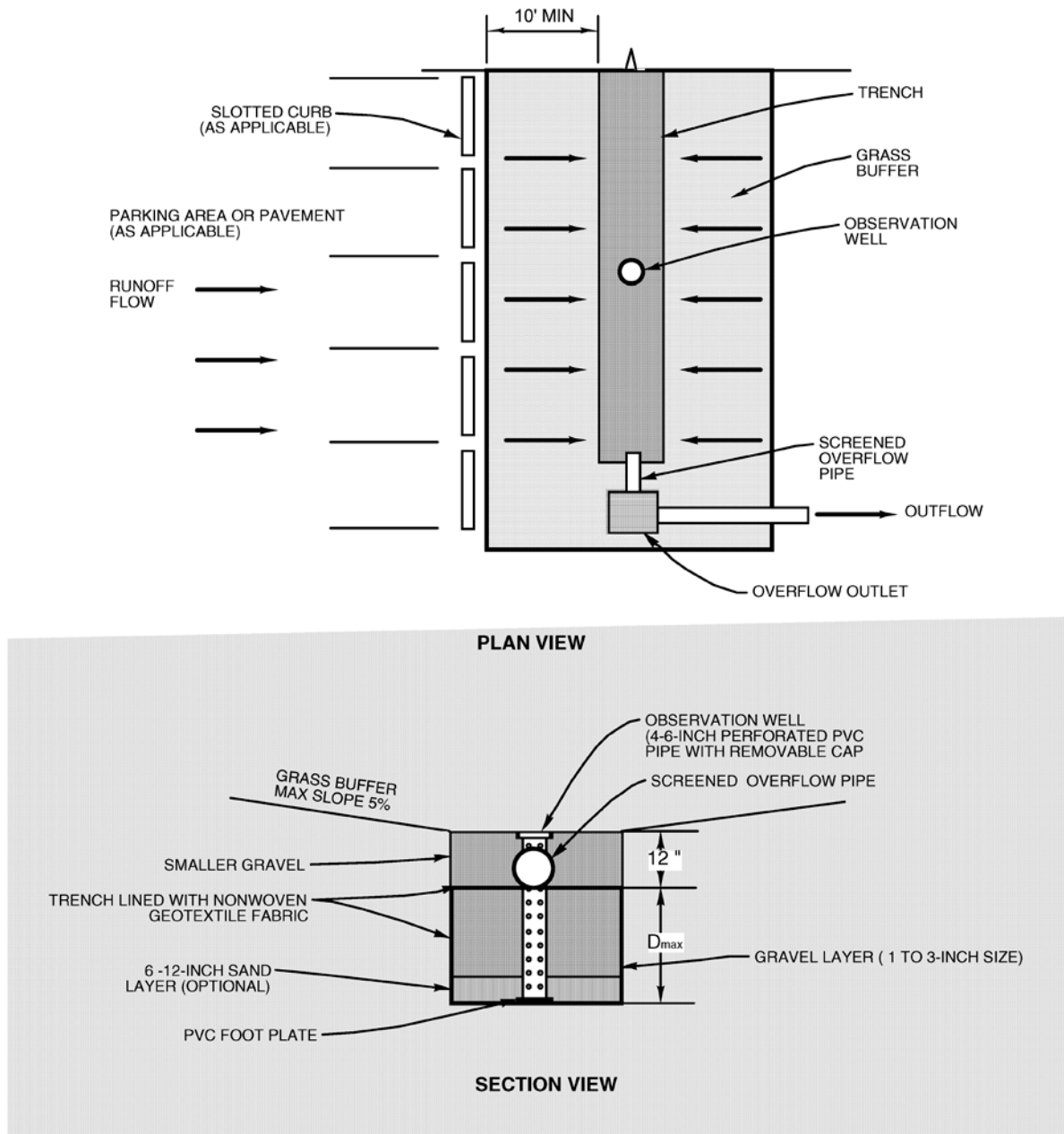

Figure IT-1. Infiltration Trench

# Infiltration Trench

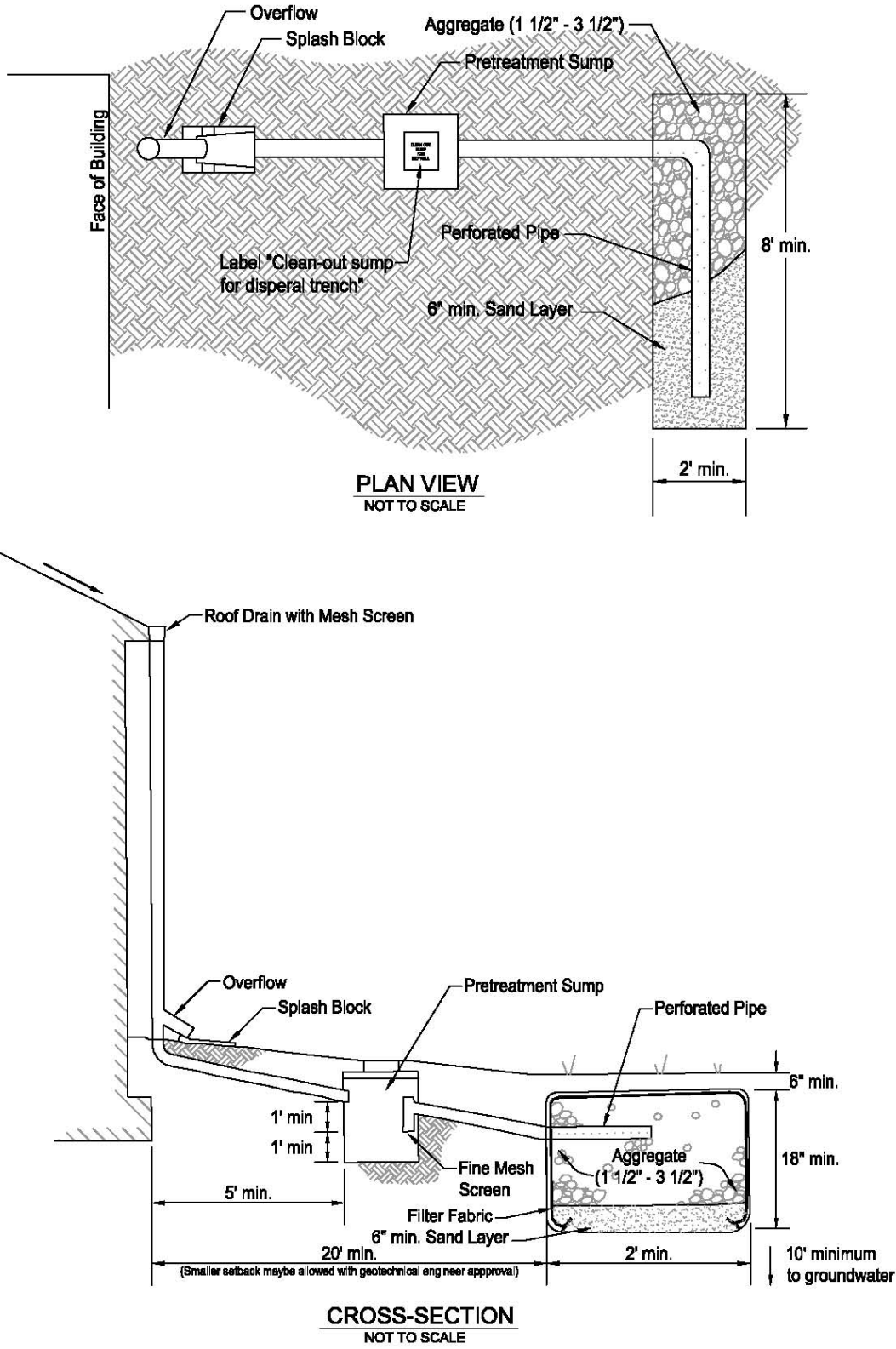

Figure IT-2. Infiltration Vault

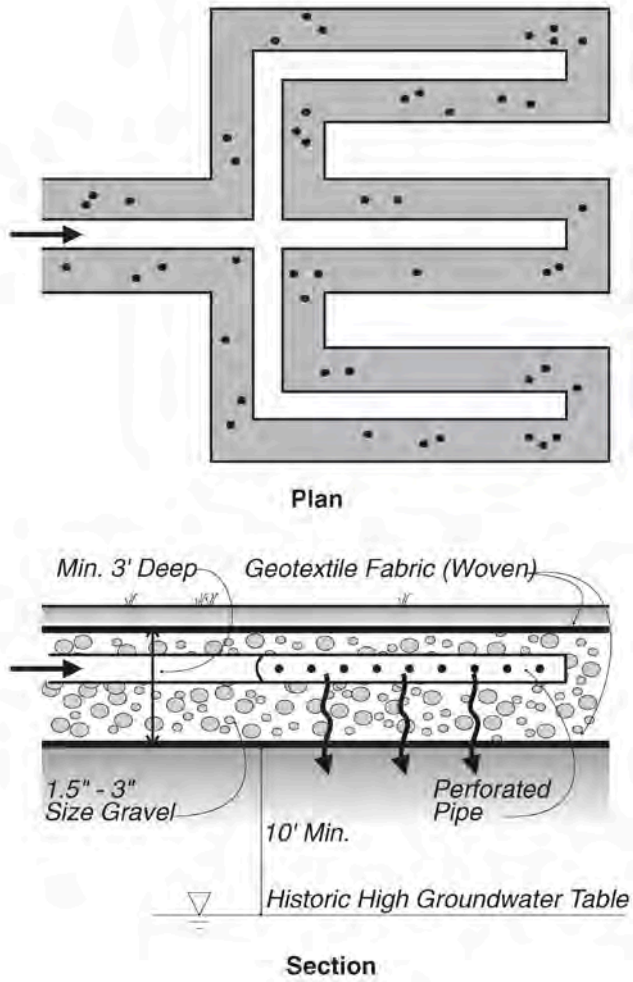

Figure IT-3. Infiltration Leach Field

Table IT-3. Design Data Summary Sheet for Infiltration Trench

**Designer:** \_\_\_\_\_ **Date:** \_\_\_\_\_  
**Company:** \_\_\_\_\_  
**Project:** \_\_\_\_\_  
**Location:** \_\_\_\_\_

**1a. Determine Design Water Quality Volume**

a. Contributing drainage area Area = \_\_\_\_\_ ft<sup>2</sup>  
 b. Water Quality Volume WQV = \_\_\_\_\_ ft<sup>3</sup>

**1b. Adjust Volume Up for Hydromodification Management (If Applicable) Based upon SAHM Modeling**

a. Water Quality Volume based on SAHM modeling V = \_\_\_\_\_ ft<sup>3</sup>  
 b. SAHM Model Demonstrates Compliance with Flow Duration Standards (Yes or No) \_\_\_\_\_

**2. Determine Maximum Allowable Depth ( $D_{max} \leq 10$  ft)**

a. Maximum drawdown time (t=48 hours) t = 48 hrs  
 b. Site infiltration rate (I) I = \_\_\_\_\_ in/hr  
 c. Safety factor (s) s = \_\_\_\_\_  
 d. Gravel porosity (P) P = 0.30  
 e.  $D_{max} = \frac{t_{max} \times I}{12 \times s \times P}$   $D_{max} =$  \_\_\_\_\_ ft

**3. Determine Minimum Trench Bottom Surface Area**

( $A_{min} = WQV/D_{max}$ )  $A_{min} =$  \_\_\_\_\_ ft<sup>2</sup>

**4. Final Design Trench Dimensions**

a. Trench length (L) L = \_\_\_\_\_ ft  
 b. Trench width (W) W = \_\_\_\_\_ ft  
 c. Trench depth (D) D = \_\_\_\_\_ ft

**5. Observation well diameter** Diam. = \_\_\_\_\_ in

**Notes:** \_\_\_\_\_  
 \_\_\_\_\_  
 \_\_\_\_\_



# Interceptor Trees

---

## Description

Interceptor trees are those used in residential and commercial settings as part of the stormwater quality management plan to reduce runoff and pollution from the development project. Interceptor trees can be placed on residential lots, throughout landscape corridors, in commercial parking lots, and along street frontages. Trees installed in municipal right-of-ways may be protected through ordinances and can provide years of aesthetic benefit.



*Photo source unknown*

## Siting Considerations

- Soils: Drainage and soil type must support selected tree species.
- Location: Locate within 25 feet of impervious surface (and as close as practical depending on the species and cultivar).
- Other structures: Maintain appropriate distance from infrastructure and structures that could be damaged by roots and avoid overhead power lines, underground utilities, septic systems, sidewalks, curbs, patios, etc.

## Vector Considerations

- Potential for mosquitoes due to standing water where excess irrigation is applied or planter box is not designed to properly drain.

## Advantages

- Reduces the amount of pollutants entering the storm drain system.
- Can reduce size of downstream stormwater quality treatment measure(s) by reducing the volume required to treat.
- Enhances aesthetic values.
- Provides shade to cool pavement and reduces surface runoff temperatures.
- Aids in removal of air pollutants and noise reduction.
- Shade trees required by the permitting agency may be counted as interceptor trees.

## Interceptor Trees

- Extends life of asphalt paving.
- Potential LEED Credits
  - Credit 6.1 – Stormwater Design – Quantity Control

## Limitations

- Fire safety may be a consideration in areas with increased risk for fire hazard.
- Root systems can damage pavement and other structures if trees are not selected and installed correctly.
- Incorrect tree selection can result in high irrigation costs and pest infestation.

## Maintenance Recommendations

- Pruning of trees may be required to maintain tree, ensure safety, and prevent damage to structures.
- Diseased/damaged trees, and those with poor structure, should be removed and replaced as soon as possible.
- Irrigation system may be required in perpetuity.

## How Do Interceptor Trees Protect Water Quality?

Interceptor trees are ideal for all projects, including those where space is limited, in which trees can be placed along street frontages and in common space. Urban areas with higher numbers of trees exhibit hydrology more similar to natural conditions compared to urban areas without a tree canopy. Trees intercept storm water and retain a significant volume of the captured water on their leaves and branches allowing for evaporation and providing runoff reduction benefits. For example, a large oak tree can intercept and retain more than 500 to 1,000 gallons of rainfall in a given year (Cappiella, 2004). While the most effective Interceptor Trees are large canopied evergreen trees, deciduous trees can also provide a benefit. For example, a leafless Bradford pear will retain more than one half the amount of precipitation intercepted by an evergreen cork oak (Xiao et al., 2000).

The shade provided by trees keeps the ground under the trees cooler, thereby reducing the amount of heat gained in runoff that flows over the surface under the trees. This attenuation of heat in storm water helps control increases in stream temperatures. On slopes, tree roots hold soil in place and prevent erosion. Mulch provided under the tree will also help trap moisture.

## Planning and Siting Considerations

Check with the local permitting agency about requirements for trees located in public utility easements. A tree permit may be required to plant, prune or remove such trees. Also, consultation with an arborist and the local master tree list is recommended for selecting and locating appropriate tree species for the unique site conditions. When trees are planted in the right-of-way, consider

including curb cuts to provide additional water to the trees and potentially improve management of street runoff.

### New trees

- Select trees from a list of approved species established by the permitting agency (see Table INT-1 for examples, but check with appropriate agency for verification). Native species and those with a larger canopy at maturity are generally preferred, depending on available space for root and canopy. Match hydro-zone of existing trees where possible.
- Select tree species based on the soils found on the site, available water, and aesthetics. Consult a landscape architect or arborist to ensure suitability of species for site conditions and design intent.
- Do not plant monocultures of same family, genus and/or cultivar. Do not plant trees too close together. Plant selection and spacing should be per the recommendations of the landscape architect or arborist.
- Interceptor trees should be incorporated into the site's general landscaping plan, but trees designated for storm water credits must be clearly labeled on plans submitted for local agency approval and other planning submittals.
- Do not place trees near structures that may be damaged by the growing root system. These include, but are not limited to, overhead utilities and lighting, underground utilities, fire hydrants, signage, septic systems, curb/gutter and sidewalks, paved surfaces, building foundations and existing trees. Consideration should also be given to fire truck access routes and pedestrian pathways. Utilize approved root barriers (deflectors) when trees are planted close to infrastructure, per the local permitting agency standards.
- Plan for parking lot shading that may be required, depending on the jurisdiction.

### Existing trees

- New landscaping under existing trees must be carefully planned to avoid any grade changes and any excess moisture in trunk area, depending on tree species. Existing plants which are compatible as to irrigation requirements and which complement the trees as to color, texture and form are to be saved.
- Grade changes greater than six inches within the critical root zone should be avoided. Also, soil compaction and texture in the drip-line area greatly affect tree survival.

## Examples of Suitable Uses of Interceptor Trees



*Residential: large and small subdivisions, small-scale developments, located in or out of municipal right-of-way. The tree pictured is an evergreen Camphor.*



*Commercial: plazas and courtyards, landscape areas in parking lots and road frontages.*



*Industrial: Employee parking lots, entryway features, and road frontages.*



*Parks and Open Space: parking lots, park hardscape areas.*

## Variations

Three types of interceptor trees are discussed in this fact sheet: 1) new evergreen trees, 2) new deciduous trees, and 3) existing trees.

### New Evergreen Trees

Evergreen trees provide the greatest benefit to water quality. Generally, the larger the tree and the smaller the leaves, the more rain is intercepted. Further, evergreen trees retain their leaves throughout the rainy season.

### New Deciduous Trees

Since the interceptor tree’s water quality benefit increases with increasing surface area of leaves and branches, deciduous trees, which lose their leaves early in the Central Valley’s rainy season, have less value than evergreen trees. However, even deciduous trees contribute to interception and shading, and credits are applied for inclusion of such trees in site plans.

### Existing Trees

Conservation of existing trees provides aesthetic value to a site as well as a water quality benefit. Credits may be applied for protected trees located within 25 feet of an impervious surface, as long as the trees are not located in the designated “open space” for the project, for which credit has already been applied.

## Design Criteria

Design criteria for interceptor trees are listed in Table INT-1.

*Table INT-1. Design Criteria for Interceptor Trees*

Also see Appendix D for information on calculating runoff reduction credits and a list of Trees Qualifying for Interceptor Tree Runoff Reduction Credits.

Variation/Parameter	Criteria
<b>All Planted Trees</b>	
Size	15 gallon container (minimum) or as acceptable by the local agency
Location	Must be planted within 25 feet of ground-level impervious surfaces. Must be spaced such that the crowns do not overlap (at 15 years of growth).
Installation and Irrigation	Trees must be installed and irrigated in accordance with local permitting agency Landscaping Standards.

## Interceptor Trees

Variation/Parameter	Criteria
<b>New Evergreen and Deciduous Trees</b>	
Size and Species	See Appendix D for suggested tree species meeting size requirement.
<b>Existing Trees</b>	
Species	Any appropriate tree species.

## Construction Considerations

### New Trees

- Do not allow soil in planter areas to be compacted during construction.
- Do not allow soil in planter areas to become contaminated with construction related materials such as lime or limestone gravel, concrete, sheetrock, or paint.
- Install irrigation system according to proper specifications.
- When installing lawn around trees, install the grass no closer than 24 inches from the trunk.
- Install protective fencing if construction is ongoing, to avoid damage to new trees.
- Mulch with hardwood chips (not redwood or cedar) 4"-6" installed depth (2"-3" settled depth).
- Do not use pressure treated stakes. Do not stake into or through the root ball. Stakes should be set perpendicular to the prevailing wind. Stakes should be cut off 1"-2" above the highest tree tie.

### Existing Trees

- Proposed development plans and specifications must clearly state protection procedures for trees that are to be preserved.
- Existing trees must be protected during construction through the use of high-visibility construction fencing set at the outer limit of the critical root zone. The fence must prevent equipment traffic and storage under the trees. Excavation within this zone should be accomplished by hand, and roots 1/2" and larger should be preserved. It is recommended that pruning of the branches or roots be completed by, or under the supervision of, an arborist. Soil compaction under trees should to be avoided.
- Ensure that trees that receive irrigation continue to be watered during and after construction.

## Long-term Maintenance

Maintenance recommendations for interceptor trees are provided in Table INT-2. The property owner is responsible for all costs associated with the maintenance.

Trees that are removed or die should be replaced with similar species, or all water quality benefits will be lost. Trees should be properly pruned for safety purposes, to protect structures, or for the improvement of the health and structure of the tree. The property owner is responsible for all costs associated with the replacement of interceptor trees.

*Table INT-2. Inspection and Maintenance Recommendations for Interceptor Trees*

Activity	Description
Removal of Leaves and Debris	Fallen leaves and debris from tree foliage should be raked and removed regularly to prevent the material from being washed into the storm water. Nuisance vegetation around the tree should be removed when discovered. Dead vegetation should be pruned from the tree on a regular basis.
Pruning	It is recommended that a certified arborist or similarly qualified professional be retained to prune trees, or the property owner should learn proper pruning methods. A tree should never be topped. Topping is the practice of removing major portions of a large tree's crown by cutting branches to stubs or to the trunk. Tree topping shortens the life of the tree, creates weakly attached limbs prone to breakage, decay and disfigures the tree. It also eliminates the interception canopy.
Mulching	Add 4-6 inch deep hardwood mulch around newly planted trees and shrubs (avoid redwood and cedar, it is light and blows away and does not decompose fast enough to be beneficial to the soil health and tree's growth).
Irrigation	An irrigation system should be installed at the time of planting and maintained during the establishment period or, if necessary to maintain the tree, in perpetuity.
Pesticides and Fertilizers	Minimize the use of chemicals to only what is necessary to maintain the health of the tree. Consider using mulch around the base of the tree as a substitute to fertilizer. Do not place mulch within six inches of the trunk of the tree.
Lawn Maintenance	Keep lawn at least 24 inches from trunk of tree. Competition from turfgrass stunts tree growth, and even additional fertilizer and water will not overcome this effect. A bare area around the trunk also helps prevent injury to the tree from a mower or string trimmer. Trunk wounds to a young tree can have a severe dwarfing effect.
Other Activities	Plant evergreen shrubs and ground covers around trees when possible. Care should be taken when digging near tree roots. Once tree has become established, planting of vegetation near base of tree and subsequent watering of such vegetation may result in over-saturation and damage to the tree.
Removal/ Replacement	See Long-term Maintenance

## References

- Bay Area Stormwater Management Agencies Association, *Start at the Source - Design Guidance Manual for Stormwater Quality Protection*, 1999.
- Cappiella, K., *Urban Watershed Forestry Manual (draft)*. Prepared for USDA Northeastern Area State and Private Forestry, Center for Watershed Protection, Ellicott City, MD, 2004.
- City of Davis, *City of Davis Community Forest Management Plan*, September 11, 2002. [www.cityofdavis.org/pcs/trees/cfmp.cfm](http://www.cityofdavis.org/pcs/trees/cfmp.cfm)
- City of Portland, *City of Portland Stormwater Management Manual*. Revision 3, September 1, 2004.
- City of San Jose, *Post-Construction Urban Runoff Management*. City Council Policy. February 3, 1998.
- Schueler T., Swann C., Wright T, and S. Sprinkle, *Urban Subwatershed Restoration Manual No 8: Pollution Source Control Practices*, Version 1.0, Center for Watershed Protection, Ellicott City, MD, July 2004.
- SMRC, *The Stormwater Manager's Resource Center. Manual Builder*. [www.stormwatercenter.net/Manual\\_Builder/Credits/SITE/reforestation.htm](http://www.stormwatercenter.net/Manual_Builder/Credits/SITE/reforestation.htm)
- United States Environmental Protection Agency, *National Menu of Best Management Practices for Storm Water Phase II*, 2002. <http://cfpub.epa.gov/npdes/stormwater/menuofbmps/index.cfm>
- Xiao Q., and E.G. McPherson, *Rainfall interception by Santa Monica's municipal urban forest*. Urban Ecosystems, 2003.
- Xiao, Q., E.G. McPherson, S.L. Ustin and M.E. Grismer, *A new approach to modeling tree rainfall interception*, Journal of Geophysical Research 105(D23) :29,173-29,188, 2000.
- Xiao, Q. *Rainfall interception by urban forests*. Davis, CA: University of California. Ph.D. Dissertation, 1998.
- Xiao, Q., E.G. McPherson, S.L. Ustin, M.E. Grismer, and J.R. Simpson, *Winter rainfall interception by two mature open grown trees in Davis, CA*. Hydrological Processes. 14(4) :763-784, 2000.

Photo credits: All photographs provided by Dena Parish and Shannon Brown, ECORP Consulting, Inc., Rocklin, CA



# Porous Pavement

---

## Description

Porous pavement allows stormwater runoff to infiltrate into the ground through voids in the pavement materials. There are many types of porous pavement, including pervious concrete and asphalt, modular block, reinforced grass, cobblestone block and gravel. When properly installed, and in the proper setting, porous pavement can be as functional and durable as traditional surfaces.



*Photo source: City of Elk Grove*

## Siting Considerations

- Soil permeability.
- Depth to groundwater: minimum 10 feet below aggregate base.
- Grade: 10% maximum.
- Loading: pavement material and design must accommodate anticipated load.

## Vector Considerations

- Potential for mosquitoes due to standing water (at or near the surface) will be greatly reduced or eliminated if the porous pavement is properly designed, constructed, and operated to maintain its infiltration capacity.

## Advantages

- Replaces regular pavement, so does not require additional land on the site.
- Can reduce size of downstream stormwater quality treatment measures by reducing the volume required to treat.
- Allows for tree preservation in areas requiring pavement.
- Sometimes more attractive than traditional pavement.
- Potential LEED Credits
  - Credit 6.1 – Stormwater Design – Quantity Control
  - Credit 6.2 – Stormwater Design – Quality Control

## Limitations

- Do not use on sites with a likelihood of oil, grease or other hazardous spills.
- Certain types (e.g., modular block pavement) may not be acceptable to local fire authority.

## Porous Pavement

- Porous asphalt will be considered on case-by-case basis.
- Pervious pavements may need to be replaced after several years, depending on the amount of fine material deposited on the surface.

### General Maintenance Recommendations (Low to Moderate<sup>1</sup>)

- Block pavers with voids filled with sand or sandy loam may require occasional replacement of fill material if infiltration capacity is lost.
- All of the hard surfaces will benefit from occasional vacuuming.
- Grassed pavements require regular mowing.

## How Does Porous Pavement Work?

Porous pavements include a variety of stabilized surfaces with void spaces designed to infiltrate stormwater runoff into the ground or slowly release the water into a subsurface drainage system. Using porous pavement minimizes impervious areas, thereby reducing the amount of site runoff requiring treatment.

## Planning and Siting Considerations

### Development Type / Land Use

In developments where it is difficult to provide stormwater treatment (such as small or redeveloping sites or high-density residential developments), porous pavement may provide the best or only opportunity to reduce site imperviousness.

All land uses contain potentially suitable locations for porous pavement. Consider porous pavement for:

- Residential driveways, patios, and walkways (also see Alternative Driveway Fact Sheet elsewhere in this chapter).
- Commercial plazas and courtyards, overflow parking areas, parking stalls, some types of storage areas, walkways, and entryway features.
- Employee parking and entryway features at industrial sites.
- Fire lanes, maintenance access roads and other roadways where infrequent or low traffic loads and volume are expected (check with fire department for minimum specifications).
- Within parks and open space for parking areas, sports courts, playgrounds, and pedestrian/bike trails.

Porous pavement is not suitable for commercial drive aisles, loading areas, and waste management areas. It is also not appropriate where spills may occur, due to the potential for soil and groundwater contamination. Such areas include retail gas outlets, auto maintenance businesses, processing/manufacturing areas, food-handling businesses, and chemical handling/storage areas.

---

<sup>1</sup> Compared to stormwater quality treatment control measures.

## Other Siting Considerations

- Consult a geotechnical engineer to determine what types of porous pavement are suitable for the expected traffic load, speed, and volume.
- Consult a geotechnical engineer to determine set back from building foundation, or use 10 feet.
- Determine site soil type and permeability before selecting porous pavement as a runoff reduction strategy. The local permitting agencies will require a permeability soils test to verify infiltration capacity of native soils. May be used over soils with low permeability in selected situations if underdrain is provided (check with permitting agency to verify).
- Address seasonal shrink/swell in sites with expansive subgrade. Use the expansion index test (ASTM D4828) to provide insight as to degree of surface deformation in choosing paving sections.
- Consider opportunities for directing runoff from impervious surfaces across porous pavement to achieve runoff reduction credits. See the Disconnected Pavement Fact Sheet located elsewhere in this chapter.
- Select the porous pavement type based on the type of anticipated pedestrian traffic; most types of porous pavement can be designed to be Americans with Disabilities Act (ADA) compliant.
- A water barrier or interceptor drain will be required where porous material abuts regular asphalt/concrete pavement and there is concern about water infiltrating the regular pavement subbase. The water barrier should run down the 12-inch deep excavation and 12 inches under the drain rock. Interceptor drains should tie into an open landscape area or treatment control measure to quickly relieve the water pressure in the pavement section and prolong the pavement life.
- For manufactured products, check the manufacturer's specifications for any additional siting considerations.



*A water barrier or interceptor drain will be required between regular load-bearing pavement/streets and porous pavement materials. Photo: City of Portland*

## Porous Pavement Types

Six types of porous pavement material are presented in this fact sheet: 1) pervious concrete, 2) pervious asphalt (considered on case-by-case basis), 3) modular block, 4) reinforced grass, 5) cobblestone block and 6) gravel. Additional types may be allowed on a case-by-case basis; check with the local permitting agency for verification before proceeding with design.

### Pervious Concrete and Asphalt

Pervious concrete and pervious asphalt have a higher load-bearing capacity than the other porous pavement options discussed in this chapter. Table PP-1 (presented later in this chapter) lists and compares the design criteria for all featured porous pavement types.

Pervious concrete is poured like traditional concrete pavement, but is made from a specially formulated mixture of Portland Cement and no sand; the result is 15% to 21% void space. See Figure PP-1 for a typical installation detail.

Colorants can be added for aesthetic reasons, and surfaces can be ground for smoothness. Owners, architects, and engineers are encouraged to visit local sites where pervious concrete has been installed before deciding to use the material (see list of selected local installations in Table PP-3 at the end of this fact sheet).

Pervious asphalt consists of an open-graded coarse aggregate, bound together by asphalt cement into a coherent mass, with sufficient interconnected voids to provide a high rate of permeability. As long as the appropriate asphalt mix and design specification is used, pervious asphalt may be as durable as regular asphalt (Adams 2003). Pervious asphalt is less expensive than pervious concrete, but both types cost more than regular asphalt or concrete.

Most available pervious asphalt design specifications include the use of a collection system and underlying recharge bed, which at this time are not being proposed. Pervious asphalt installations are currently being examined, and it is anticipated that applicable design standards will soon be available. Pervious asphalt may be accepted for installation as specifications are developed, and at the discretion of the permitting agency. Additional information will be included in future manual updates.

The key to success with both pervious concrete and asphalt is proper installation by certified or otherwise experience contractors, and protection during construction activities to prevent clogging by fine construction sediment.



*Pervious concrete parking lot; Bannister Park, Fair Oaks, CA. Photo: CNCPC and Fair Oaks Recreation and Parks District*



*Pervious asphalt roadway.  
Photo: City of Portland*

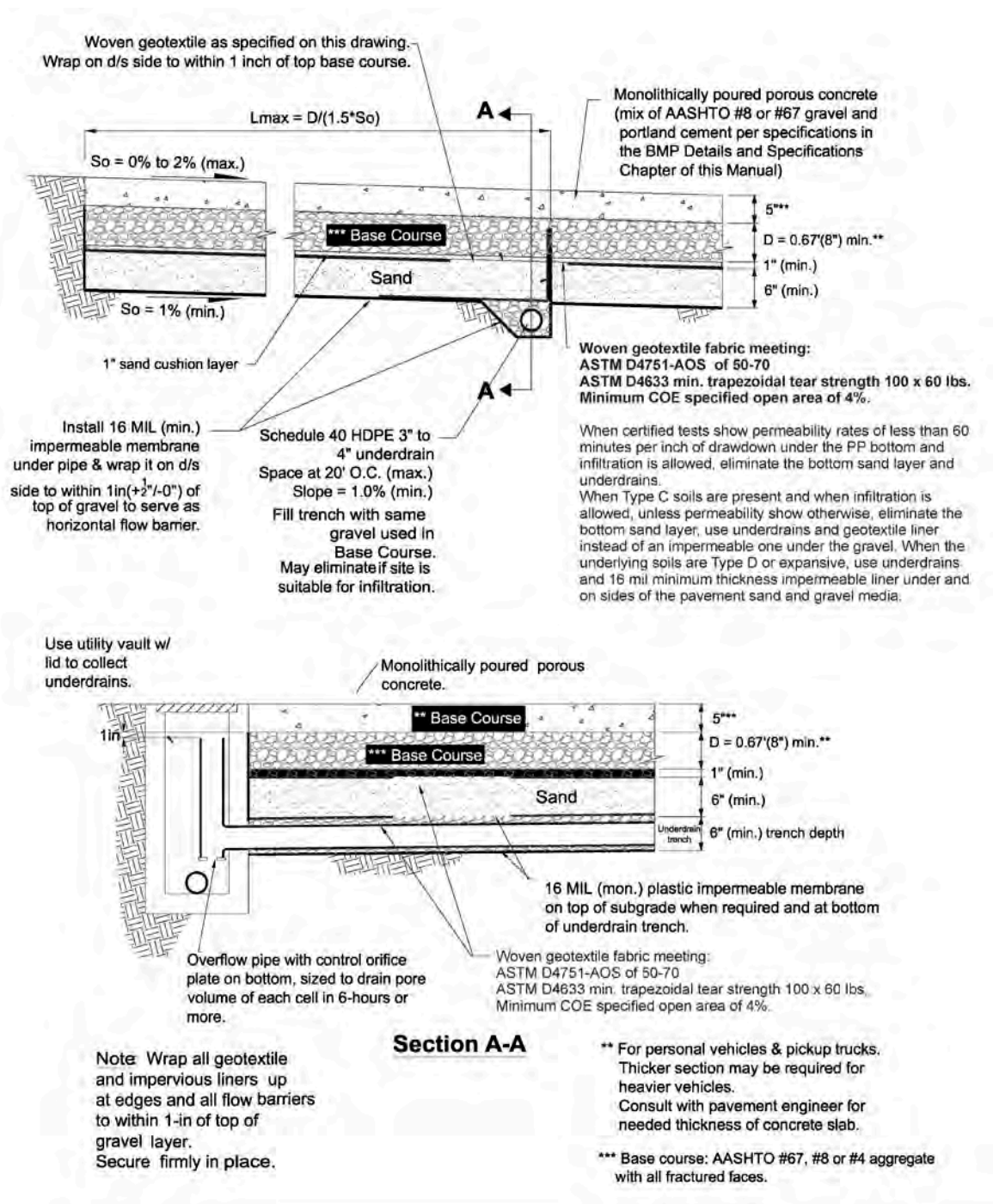

Figure PP-1. Typical Pervious Concrete Sections\*

(Source: adapted from Denver)

\*Installation specifications may vary by site; check with local permitting agency.

## Modular Block Pavement

Porous modular block pavement (Figure PP-2) consists of concrete blocks with 20% or more open area, which is filled with sand or sandy loam turf. The units are installed over a gravel subgrade. This type of pavement is best suited for areas with low traffic loadings and seasonal/infrequent vehicle traffic, such as courtyards, driveways, overflow parking areas, and maintenance access roads. Check with the local fire authority about whether this option is acceptable for fire access lanes. One benefit is that it does not require utility cuts; instead the blocks can be taken out and replaced after utilities have been installed. Refer to Table PP-1 for design criteria for this type of porous pavement.



Photo: M&C Pavers, Florida

Other Names: Open-celled unit pavers, turf block, Grasscrete™

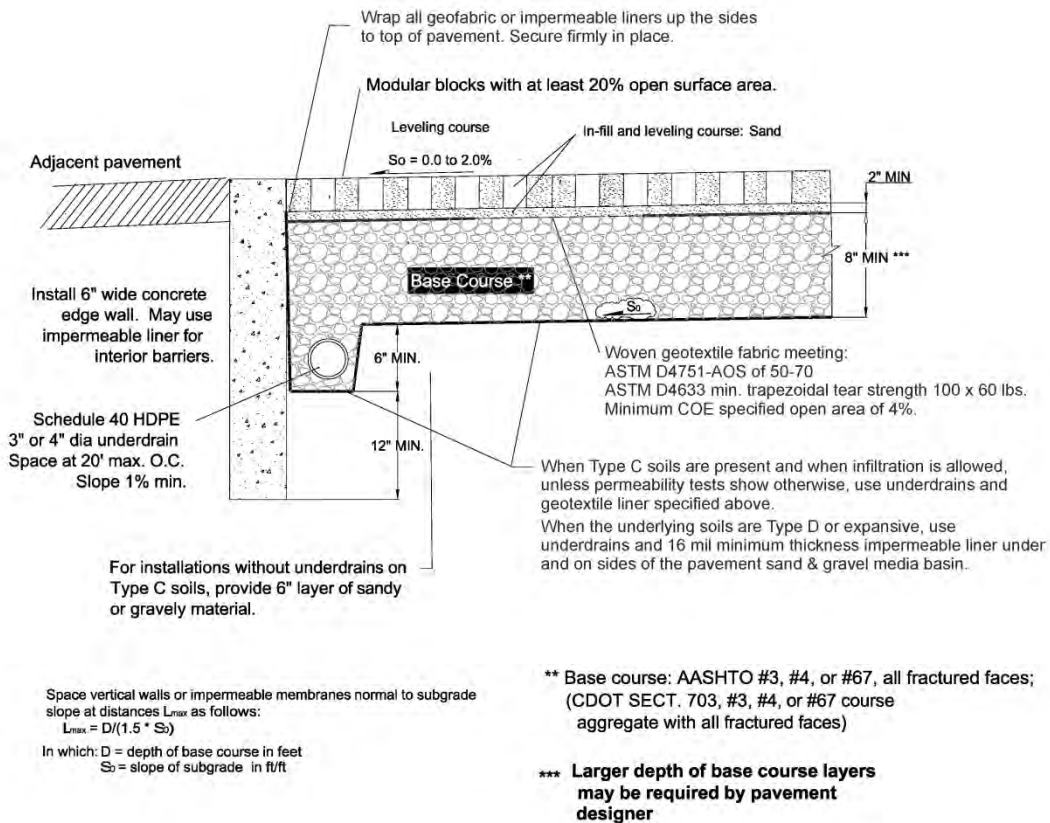

Figure PP-2. Modular Block Pavement, Typical Section\*

(Source: adapted from Denver)

\*Installation specifications may vary by site; check with local permitting agency.

## Reinforced Grass Pavement

Reinforced grass pavement (Figure PP-3) consists of an irrigated surface, typically stabilized with a manufactured product over which soil and seed mix is spread. Of the various porous pavement options, this may provide the greatest stormwater quality benefit due to its high permeability and evapotranspiration and nutrient uptake by vegetation. This pavement type is well suited in low-traffic areas, such as overflow parking areas (stalls can be marked with athletic field paint) and maintenance roads (source: NEMO). However, it is not suitable for fire access lanes. Load-bearing capacity varies by product, so select the reinforcement grid based on anticipated load. Because of the reinforcement, the area can be used even when the ground is saturated. Irrigation is required to maintain the vegetation. Refer to Table PP-1 for design criteria for this type of porous pavement.

*Other names:* grid pavers, green parking, Grasspave™



*New installation of reinforced grass pavement. Photo: Puget Sound Action Team, WA*

## SPECIFICATIONS

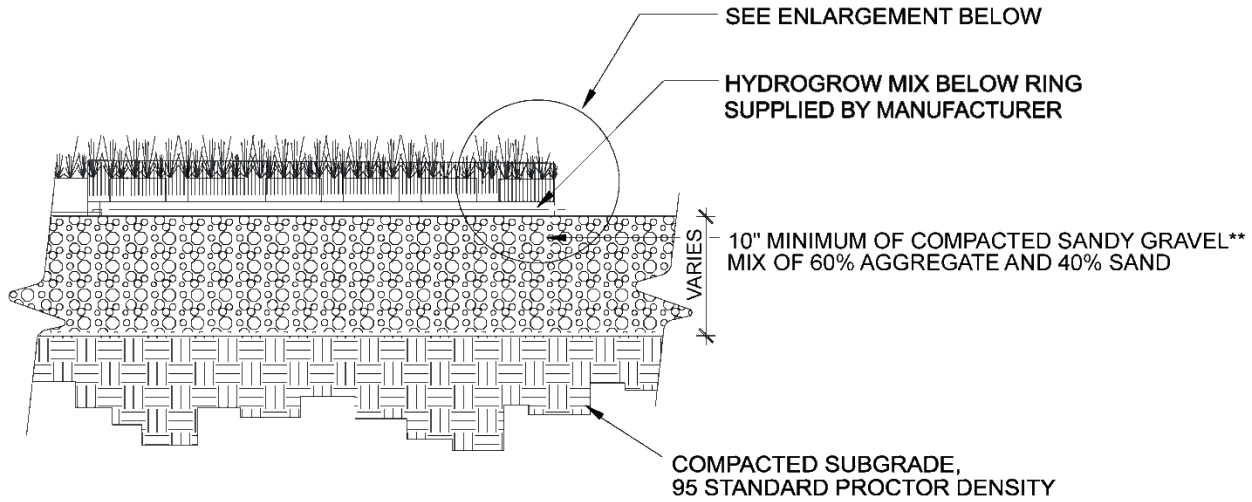

### SECTION

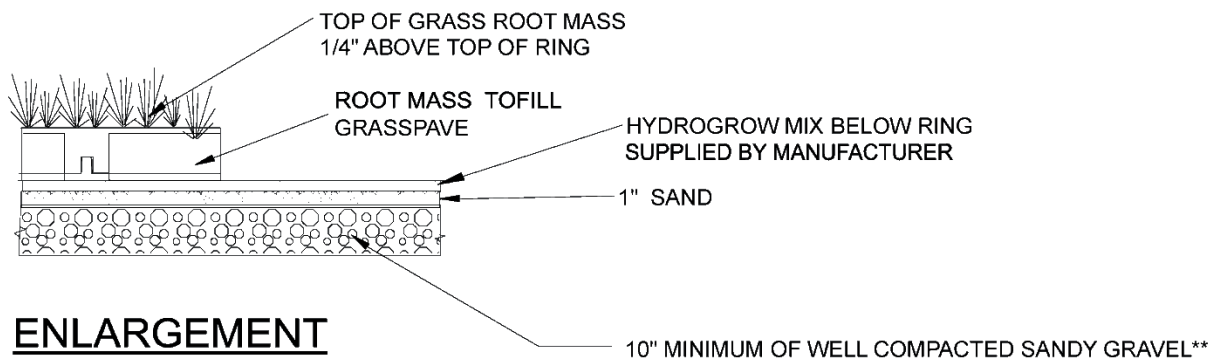

### ENLARGEMENT

**NOTES:**

1. INSTALL GRASSTURE REINFORCING LAYER PER MANUFACTURER'S RECOMMENDATIONS INCLUDE MODIFICATIONS SHOWN ON THIS DRAWING.
2. DETAIL BASED ON INVISIBLE STRUCTURES, INC., ET AL DETAILS, BUT MODIFIED TO SUIT USDCM REQUIREMENTS.

**\*\*GREATER DEPTH OF PAVEMENT MAYBE REQUIRED BY PAVEMENT DESIGNER**

*Figure PP-3. Reinforced Grass Pavement, Typical Sections\**

(Source: adapted from Denver)

\*Installation specifications may vary by site; check with local permitting agency.



## Cobblestone Block Pavement

Cobblestone block pavement (Figure PP-4) consists of concrete block units with at least 8% void space where the beveled corners meet. The units are installed on a gravel subgrade, and the void space is filled with sand. This is one of the most attractive porous pavement options and allows for the greatest flexibility in pattern and color. Cobblestone block pavement can be used wherever modular block pavement is appropriate, and similarly, does not require utility cuts; instead the blocks can be taken out and replaced after utility installation. Refer to Table PP-1 for design criteria for this type of porous pavement.



Photo: Cobblestone block pavement at Fair Oaks Promenade; Fair Oaks, CA.

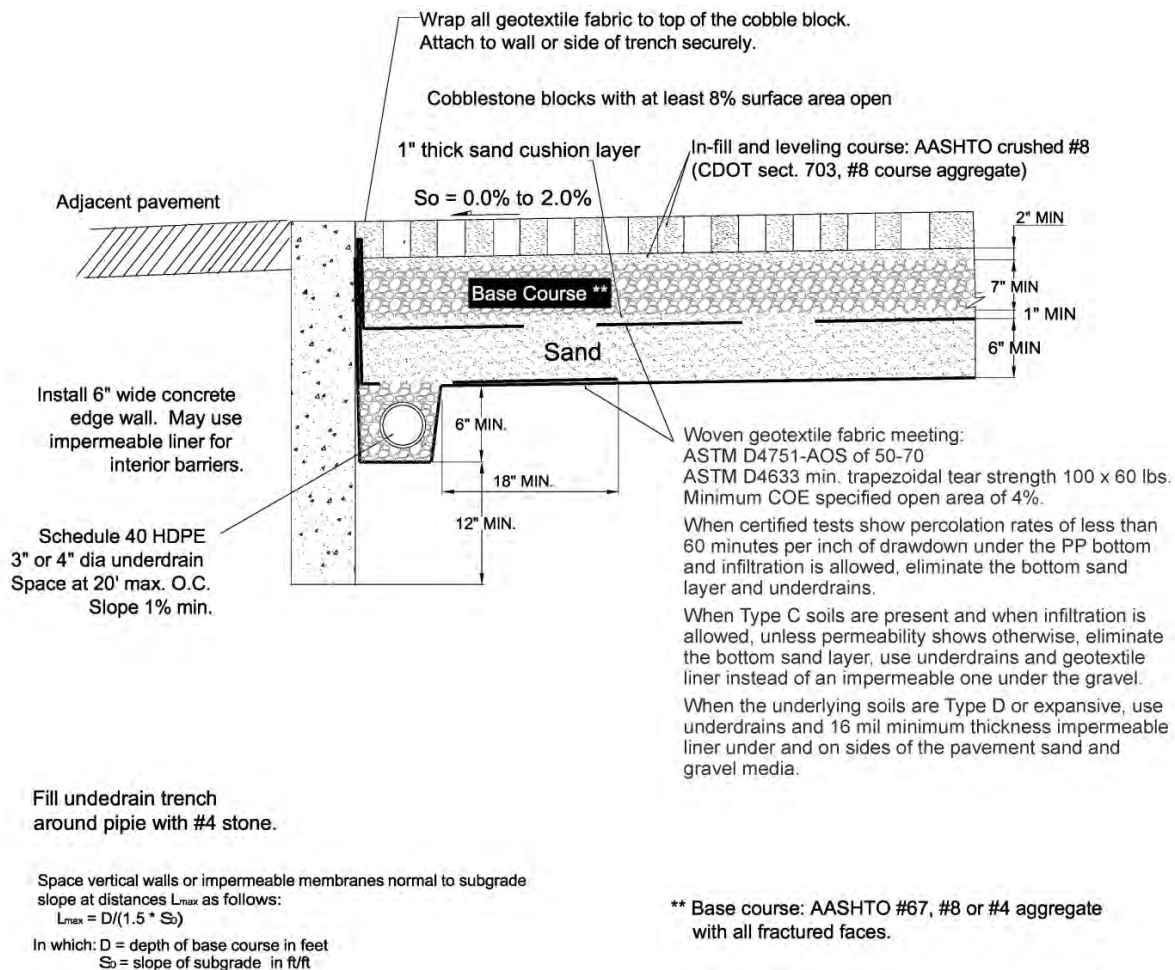

Figure PP-4. Cobblestone Block Pavement, Typical Section\*

(Source: adapted from Denver)

\*Installation specifications may vary by site; check with local permitting agency



## Design Criteria

Design criteria for porous pavement are listed in Table PP-1.

*Table PP-1. Design Criteria for Porous Pavement\**

Also see Appendix D for information on calculating runoff reduction credits.

Pavement Type/ Parameter	Criteria
<i>Pervious Concrete (Figure PP-1)</i>	
Void space	Minimum 15% throughout material
Base Course	With underdrain – 8” minimum of coarse aggregate over 7” minimum sand over 3” minimum coarse aggregate; without underdrain – 12” minimum coarse aggregate
Liner	Geotextile filter cloth with 60 to 80 pores per inch
Underdrain	Required when specified permeability range is not available in native soils. Use a gravel trench or perforated pipe embedded in a 6-12-inch layer of crushed rock. Connect to another LID element or the storm drain system (not sanitary sewer).
Water Barrier	Check with the geotechnical engineer.
<i>Modular Block Pavement (Figure PP-2)</i>	
Void space	Minimum 20% surface area as open annular spaces
Base Course	8” minimum of coarse aggregate
Liner	Same as pervious concrete.
<i>Reinforced Grass Pavement (Figure PP-3)</i>	
Base Course	12” minimum of compacted sandy gravel mix
<i>Cobblestone Block Pavement (Figure PP-4)</i>	
Void space	Minimum 8% surface area as open annular spaces
Base Course	7” minimum of coarse aggregate over 7” minimum of sand
Liner	Same as pervious concrete
<i>Porous Gravel Pavement (Figure PP-5)</i>	
General	With underdrain – 12” minimum of coarse aggregate over 7” minimum sand over 3” minimum coarse aggregate; without underdrain – 14” minimum coarse aggregate
Liner	Same as pervious concrete
<p>Source: Urban Drainage and Flood Control District. Denver, Colorado</p> <p>*Design criteria may vary by permitting agency; check before proceeding with design. A permeability test will be required to verify suitability of this technique for the site. A qualified engineer must provide site-specific design specifications for pavement installation. In addition, the manufacturer’s specifications apply.</p>	

## Construction Considerations

- Proper installation is important for all porous pavement types, but it is especially critical for pervious concrete and asphalt, which must be installed by certified or otherwise qualified

contractors. Certification programs are now offered by various National and State associations (contact National Ready Mixed Concrete Association for more information).

- The designer should define compaction criteria to protect infiltration capacity of pervious materials and satisfy roadway loading requirements.
- Weather conditions can affect the final product. Avoid extremely high or low temperatures during installation. The bottom of the crushed rock reservoir below the pavement should be flat so that runoff will be able to infiltrate across the entire sub surface area (unless subsurface drain required).
- Additional information must be incorporated into construction specifications depending on the type of porous pavement proposed and addressing site-specific pavement design. Manufacturer’s recommendations could be incorporated into the project specifications.
- After installation, and as construction continues elsewhere on the site, prevent fine sediment from clogging the material by covering the surface with plastic, using staked straw wattles around the perimeter, etc.
- As soon as possible, stabilize the entire contributing drainage area to keep sediment-laden runoff from contacting the new pavement.

## Long-term Maintenance Recommendations

Table PP-2 presents inspection and maintenance recommendations for porous pavement. The local permitting agencies will require that the property owner be responsible for maintaining the features to ensure continued, long-term performance. The pervious features should not be removed or replaced with impervious surfaces in the future, or all water quality benefits will be lost. Check with your local permitting agency to determine if and when a maintenance agreement will be required for your project.

*Table PP-2. Inspection and Maintenance Recommendations for Porous Pavement*

Surface Maintenance	<ul style="list-style-type: none"> <li>▪ Keep the surface clean and free of leaves, debris, and sediment, and do not replace or cover it with an impermeable paving surface.</li> <li>▪ Regularly sweep or vacuum pervious concrete and asphalt, modular block pavement, or cobblestone block pavement (typically three to four times per year).</li> <li>▪ Do not store loose material such as bark or sand on porous pavement.</li> </ul>
Care of Vegetation	<ul style="list-style-type: none"> <li>▪ Mow, irrigate, fertilize, and—when necessary—reseed grasses planted in pavement.</li> <li>▪ Keep grasses healthy and dense enough to provide filtering while protecting underlying soils from erosion.</li> <li>▪ Mow grass to less than four inches and remove grass clippings.</li> <li>▪ Avoid planting trees and shrubs near non-flexible porous pavement types because roots may crack pavement and excessive leaves may clog the surface. Use of structural soil material may alleviate this concern.</li> </ul>

Vector Control	<ul style="list-style-type: none"> <li>Eliminate any standing water at the surface, since that provides an environment for insect larvae.</li> <li>If sprays are considered, then use a licensed pest controller to apply an approved mosquito larvicide.</li> </ul>
Maintenance of Reinforcement Products	<ul style="list-style-type: none"> <li>Where reinforcement products are used to stabilize grass or gravel, replace individual grid sections when they become damaged.</li> </ul>
Manufacturer's Recommendations	<ul style="list-style-type: none"> <li>For manufactured products, follow manufacturer's maintenance recommendations.</li> </ul>
Replacement	<ul style="list-style-type: none"> <li>Reconstruct or replace when it is no longer functioning properly (see project lifespan in Appendix B for informational purposes).</li> </ul>

Table PP-3. Selected Local Pervious Concrete Installations

Type	Location	Contact
Residential Driveway	4600 McDonald Drive, Sacramento, CA	Private residence (do not disturb residents)
Parking Lot	Bannister Park, Miller Park and Phoenix Community Park, Fair Oaks	Fair Oaks Recreation and Park District
	Mace Ranch Park, Davis	City of Davis Parks Department
Garden (Pathways, etc.)	Fair Oaks Park Water Wise Garden, Fair Oaks	Fair Oaks Recreation and Park District
	UC Berkeley Botanical Gardens, Berkeley	UC Berkeley
School	Linden High School Pervious Parking Lot, 3247 Linden Street, Linden, CA	
Municipal Bus/Corporation Yard	City of Elk Grove Corporation Yard, Elk Grove	City of Elk Grove Public Works Department

## Resources for More Information

- California Nevada Cement Association, [www.cncement.org](http://www.cncement.org)
- Concrete Promotion Council of Northern California, [www.cpcnc.org](http://www.cpcnc.org)
- National Ready Mixed Concrete Association (NRMCA), [www.nrmca.org](http://www.nrmca.org)
- Pacific Southwest Concrete Alliance, [www.concreteresources.net](http://www.concreteresources.net)
- Northern California Asphalt Pavement Association, [www.apaca.org](http://www.apaca.org)
- National Precast Concrete Association, [www.precast.org](http://www.precast.org)
- Portland Cement Association, [www.portcement.org](http://www.portcement.org)
- National Asphalt Pavement Association, [www.hotmix.org](http://www.hotmix.org)
- Asphalt Emulsion Manufacturers Association, [www.aema.org](http://www.aema.org)
- American Concrete Pavement Association – Southwest Chapter, [www.acpa-southwest.org](http://www.acpa-southwest.org)

- Association of Asphalt Paving Technologists, [www.asphalttechnology.org](http://www.asphalttechnology.org)
- American Concrete Paving Association, [www.pavement.com](http://www.pavement.com)

## References Used to Develop This Fact Sheet

- Adams, M.C. 2003. *Porous Asphalt pavement with recharge beds: 20 years & still working.* Stormwater. May/June 2003.
- Bay Area Stormwater Management Agencies Association, *Start at the Source - Design Guidance Manual for Stormwater Quality Protection*, 1999.
- City of Portland, *City of Portland Stormwater Management Manual*. Revision 3, September 1, 2004.
- City of Portland, *Sustainable Infrastructure Alternative Paving Materials Subcommittee Report*, October 3, 2003.
- Paris N. and M. Chusid, *Coloring Pervious Pavement... because protecting the environment should be beautiful*, Dec/Jan 2006. [www.ConcreteDecor.net](http://www.ConcreteDecor.net)
- SMRC, *The Stormwater Manager's Resource Center. Fact Sheets*, accessed June 14, 2006. [http://www.stormwatercenter.net/Assorted%20Fact%20Sheets/Tool6\\_Stormwater\\_Practices/Infiltration%20Practice/Porous%20Pavement.htm](http://www.stormwatercenter.net/Assorted%20Fact%20Sheets/Tool6_Stormwater_Practices/Infiltration%20Practice/Porous%20Pavement.htm)
- United States Environmental Protection Agency, *National Menu of Best Management Practices for Storm Water Phase II*, 2002. <http://cfpub.epa.gov/npdes/stormwater/menuofbmps/index.cfm>
- University of Connecticut, *Nonpoint Education for Municipal Officials*. accessed May 26, 2006. <http://nemo.uconn.edu>
- Urban Drainage and Flood Control District, Denver, CO, *Urban Storm Drainage Criteria Manual Volume 3 – Best Management Practices*, September, 1999 (Rev. June, 2002).
- Virginia Department of Conservation and Recreation, *Virginia Stormwater Management Program Handbook*, 1999.

# Sand Filter

## Description

A sand filter is a two-stage constructed treatment system including a pretreatment sedimentation basin and a filtration basin containing sand<sup>1</sup>. The filter bed is supported by a gravel base which includes an underdrain. As stormwater flows into and through the system, large particles settle out in the first basin and finer particles and other pollutants are removed in the second basin. Runoff from large storm events in excess of the water quality design volume (WQV) is bypassed around the system. There are several variations of sand filters; this fact sheet discusses the Austin Sand Filter.



*Sand filter in parking lot.  
City of Sacramento Department of Utilities*

## Siting Considerations

- Contributing drainage area: Up to 50 acres.
- Sizing basis: Water quality volume (WQV) with 48-hour drawdown. Storm volumes in excess of the WQV must be bypassed.
- Hydraulic head: about four feet of hydraulic head is required to achieve design flow through the Austin Sand Filter.
- Total filtration basin depth (minimum): 36 inches.

## Vector Considerations

- Potential for mosquitoes due to standing water will be greatly reduced or eliminated if the sand filter is properly designed, constructed, and maintained.

## Advantages

- Provides effective water quality enhancement through settling and filtering while requiring relatively small space.
- Can be placed above or below ground.

---

### POLLUTANT REMOVAL EFFECTIVENESS

---

Sediment	High
Nutrients	Low
Trash	High
Metals	High
Bacteria	Medium
Oil and Grease	High
Organics	High

---

The following is a partial list of the most common target pollutants for the Sacramento area: copper, lead, mercury, pathogens, diazinon, and chlorpyrifos. For more complete information refer to:

[http://www.waterboards.ca.gov/water\\_issues/programs/tmdl/integrated2010.shtml](http://www.waterboards.ca.gov/water_issues/programs/tmdl/integrated2010.shtml)

Source: CASQA California Stormwater BMP Handbook, January 2003

---

## Sand Filter

- Does not require irrigation or base flow.
- Suited for most soil conditions; permeable soils are not needed.
- Reduces peak flows during small storm events.
- Potential LEED Credits
  - Credit 6.2 – Stormwater Design – Quality Control

## Limitations

- Upstream treatment controls may be needed to pretreat and remove sediment from runoff before it enters the sand filter. This will prevent or minimize clogging.
- Significant head loss through treatment units may limit use on flat sites.
- More expensive to construct than other types of treatment control measures.

## General Maintenance Recommendations (Moderate to High)

- Periodically remove debris and sediment from sedimentation basin and surface of filtration basin.
- Periodically replace sand layer in filtration basin when filtration capacity is diminished.

## How Does a Sand Filter Work?

A typical configuration of an Austin Sand Filter is shown in Figure SF-1. The principal components of the unit include a sedimentation basin and a filtration basin. The sedimentation basin is designed to hold the entire WQV and to release that volume to the filtration basin over the design drawdown time of 48 hours. Large sediment is removed from the runoff through this process. Fine particles and other pollutants are removed in the filtration basin as the runoff passes through the sand filter. Runoff in excess of the WQV is bypassed around the treatment unit.

## Variations of Sand Filters

This fact sheet focuses on the Austin Sand Filter. Other variations (also named after the area of the country where they were developed) include the underground (DC) sand filter and the linear or perimeter (Delaware) sand filter. The size of the drainage area and the facility location typically dictate what type of filter is best. For large watersheds (i.e., up to 50 acres), an Austin Sand Filter is recommended. For small catchments up to 1.5 acres requiring underground facilities, a DC Underground Sand Filter is recommended. Delaware Linear Sand Filters are especially suitable for paved sites and industrial sites (catchments up to five acres in size) because they can be situated to accept sheet flow from adjacent pavement. The units also differ in hydraulic head requirements. Approximately four feet of hydraulic head is required to achieve design flow through the Austin and DC Underground Sand Filters, whereas Delaware Linear Sand Filters can operate with as little as two feet of head.



## Planning and Siting Considerations

- Sand filters are generally suited for sites where there is no base flow and the influent sediment load is relatively low.
- Sand filters are well suited for drier areas and/or urban areas because they do not require vegetation or irrigation and require less space than most other treatment controls.
- Because the filter media is imported sand or engineered adsorptive material, sand filters are suited for most soil conditions, and the presence of permeable soils is not a requirement.
- The Austin Sand Filter may be constructed inside a concrete shell, or built directly into the terrain over an impermeable liner (e.g., clay), if site conditions allow. Figure SF-1 shows a unit within a concrete shell, with an enclosed sedimentation basin and the filtration basin open at the surface.
- Setback requirements: minimum of 10 ft vertical separation from groundwater table, and 150 ft horizontal separation from drinking water wells

## Design Criteria

Design criteria for the Austin Sand Filter are listed in Table SF-1. Use the Design Data Summary Sheet provided at the end of this fact sheet (Table SF-3) to record design information for the permitting agency's review.

*Table SF-1. Austin Sand Filter Design Criteria*

Design Parameter	Criteria	Notes
<b>Sedimentation Basin</b>		
Maximum contributing drainage area	50 acres	The larger the contributing drainage area, the larger the surface area of filter required.
Minimum basin volume	WQV or as dictated greater by SAHM modeling (for projects with hydromodification requirement)	See Appendix E in this Design Manual
Minimum/Maximum basin water depth (d <sub>SB</sub> )	3 ft/10 ft	
Minimum length:width ratio	2:1	
Maximum drawdown time	48 hrs	Based on WQV (see Appendix E)

## Sand Filter

Design Parameter	Criteria	Notes
Freeboard	1 ft	Above max water surface elevation
Maximum inlet velocity	3 ft/sec	Provide inlet energy dissipator as required to limit inlet velocity to 3 ft/sec
<b>Filtration Basin</b>		
Minimum gravel depth over sand filter (if applicable)	2 in	See Figures SF-3 and SF-4
Minimum storage volume above filter bed	20%	Based on WQV
Minimum storage depth above filter bed ( $d_s$ )	3 ft	
Minimum sand depth in filter bed ( $d_r$ )	18 in	Place geotextile fabric between sand and gravel layers
Coefficient of permeability for sand filter ( $k$ )	3.5 ft/day	0.146 ft/hour
Sand size, diameter	0.02-0.04 in	
Slope of sand filter surface	0%	Flat
Minimum gravel cover over underdrain	2 in	Gravel not required under the drain pipe
Underdrain gravel size, diameter	0.5-2 in	
Minimum inside diameter of underdrain	6 in	
Underdrain pipe type	PVC	Schedule 40 (or heavier)
Minimum slope of underdrain	1%	
Minimum underdrain perforation, diameter	0.375 in	3/8 inch
Minimum perforations per row	6	
Maximum drawdown time ( $t_r$ )	48 hrs	
Minimum gravel bed depth ( $d_g$ )	16 in	
Liner (if required)	clay	

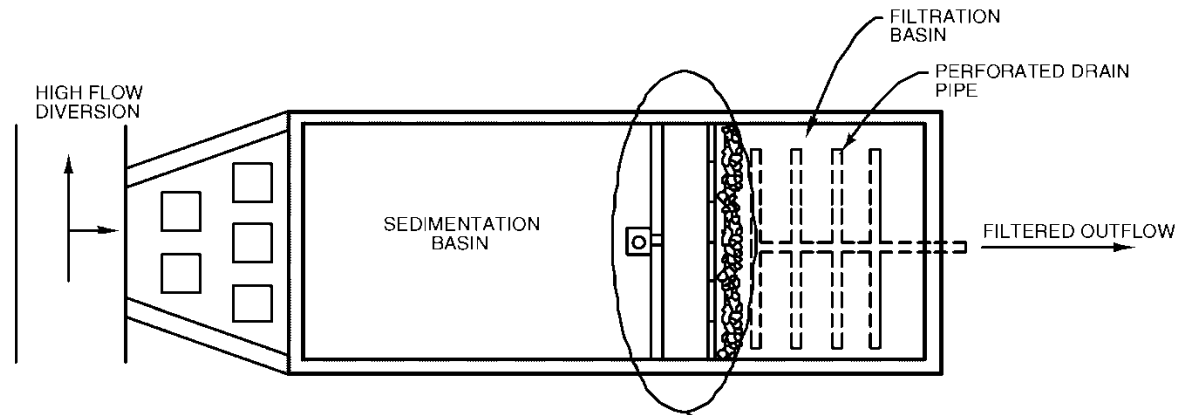

NOTE: SEDIMENTATION POND MAY BE USED IN LIEU OF CONCRETE BASIN. FILTRATION BASIN MAY BE BUILT DIRECTLY INTO GROUND OVER AN IMPERVIOUS GEOMEMBRANE IF SOIL CONDITIONS ALLOW.

PLAN  
NOT TO SCALE

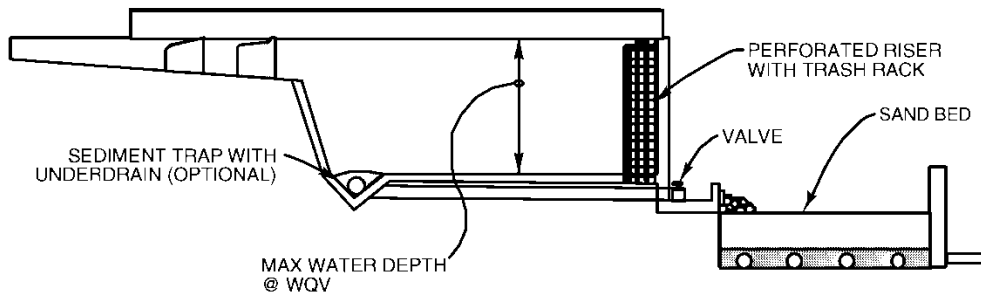
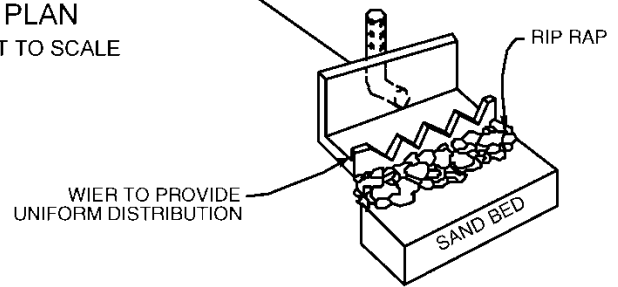

ELEVATION  
NOT TO SCALE

Source: Austin, Texas

Figure SF-1. Sand Filter Configuration (Austin Sand Filter)

## Design Procedure – Sedimentation Basin

### Step 1a – Determine Water Quality Volume (WQV)

Using the Appendix E in this Design Manual, determine the contributing drainage area and stormwater quality design volume (WQV) for 48-hour drawdown.

---

Use the **Design Data Summary Sheet** (Table SF-5) to record design information for the permitting agency's review.

---

### Step 1b – SAHM Modeling for Hydromodification Management (If applicable)

Upsize the sedimentation basin volume as necessary based upon modeling results if implementing as a hydromodification control. Maintain depth so as to adhere with 48-hour maximum drawdown for WQV.

### Step 2 – Determine Sedimentation Basin Volume ( $V_{sb}$ )

The volume of the sedimentation basin must be greater than or equal to the WQV.

$$V_{sb} = \text{WQV (minimum)}$$

### Step 3 – Determine Sedimentation Basin Water Depth ( $d_{sb}$ )

The allowable water depth in the sedimentation basin will be governed by the available hydraulic head, which will be based on the difference in elevation between the sedimentation basin inlet and the filtration basin outlet. The design  $d_{sb}$  value should be  $\geq 3$  ft and  $\leq 10$  ft. Select a design depth in the allowable range that yields the required  $V_{sb}$  given any footprint area constraints.

### Step 4 – Determine Sedimentation Basin Area ( $A_{sb}$ )

$$A_{sb} = V_{sb} / d_{sb}$$

### Step 5 – Determine Sedimentation Basin Shape

Determine overall length ( $L_{sb}$ ) and width ( $W_{sb}$ ) dimensions to yield the  $A_{sb}$  for the basin, given any footprint area constraints.

$$A_{sb} = L_{sb} \times W_{sb}$$

The length-to-width ratio should be at least 2:1. If necessary, provide internal baffling to achieve this ratio and to mitigate short-circuiting and/or dead storage problems

If the basin is not rectangular, shape the basin with a gradual expansion from the inlet and a gradual contraction toward the outlet. Design the basin to maximize the distance from the inlet (near where heavier sediment will be deposited) to the outlet structure. This configuration improves basin performance and reduces maintenance requirements.

## Step 6 – Determine Inlet/Outlet Design

Design the inlet structure to convey the water quality volume to the unit and bypass flows in excess of this volume directly to the downstream storm drain system. Provide energy dissipation at the inlet to maintain quiescent conditions needed for effective sedimentation; keep inlet velocities at three (3) feet per second or less.

The outlet structure conveys the water quality volume from the sedimentation basin to the filtration basin and should be a perforated riser pipe equipped with a trash rack to prevent clogging. Trash racks allow easy access for inspecting and cleaning outlet orifices. Size trash racks to prevent clogging of the outlet without restricting the hydraulic capacity of the outlet control orifices.

A trash rack shall be provided for the outlet. Opening in the rack should not exceed  $\frac{1}{3}$  the diameter of the vertical riser pipe. The rack should be made of durable material, resistant to rust and ultraviolet rays. The bottom rows of perforations of the riser pipe should be protected from clogging. To prevent clogging of the bottom perforations, it is recommended that geotextile fabric be wrapped over the pipe's bottom rows and that a cone of one (1) to three (3) inch diameter gravel be placed around the pipe. If a geotextile fabric wrap is not used, the gravel must be large enough not to enter the riser pipe perforations. An alternative design, such as geocomposite drain, may also be approved by the local permitting agency.

## Step 7 – Design the Basin to Avoid Short-Circuiting

Design the sedimentation basin with baffles as needed to avoid short-circuiting (i.e., flow reaching the outlet before it passes through the sedimentation basin volume).

## Step 8 – Design the Sediment Trap (Optional)

A sediment trap is a storage area that captures sediment and removes it from the basin flow regime, thereby inhibiting re-suspension of solids during subsequent runoff events and improving long-term removal efficiency. The trap also helps the basin maintain adequate storage volume by reducing sediment that would otherwise accumulate within it; this, in turn, can reduce maintenance needs. If a sediment trap is provided, size the volume to be equal to 10 percent of the sedimentation basin volume and design it to completely drain within 48 hours. Place the invert of the drain pipe above the surface of the sand bed of the filtration basin and make sure the grading of the piping to the filtration basin is at least  $\frac{1}{4}$  inch per foot (two percent slope). Provide access for cleaning the sediment trap drain system.

## Sand Filter

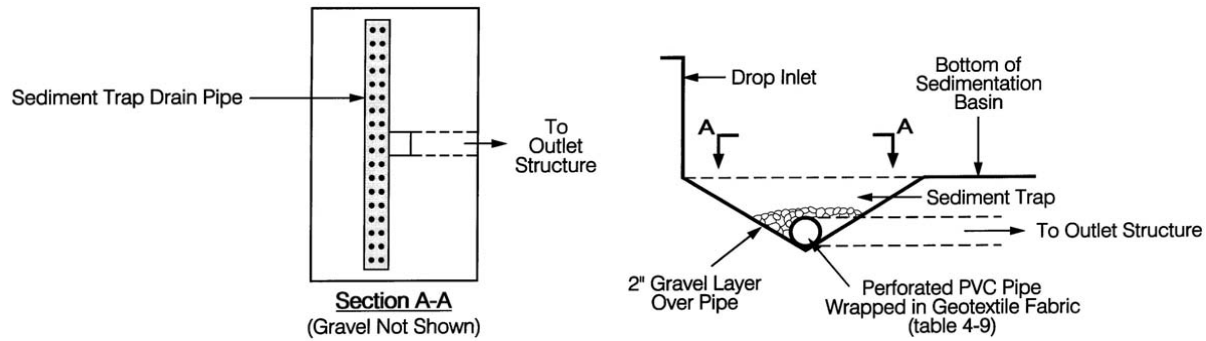

Figure SF-2. Example Sediment Trap Details

### Step 9 – Determine Sedimentation Basin Liner Design

If the sedimentation basin is an earthen structure and an impermeable liner is required to protect groundwater quality, the liner shall provide a maximum permeability of  $1 \times 10^{-6}$  cm/sec (ASTM Method D-2434). If an impermeable liner is not required, then install a geotextile fabric liner that meets the specifications listed in Table SF-3 unless the basin has been excavated to bedrock.

## Design Procedure – Filtration Basin

The design procedure and application of design criteria for the Austin Sand Filter Filtration Basin are outlined in the following steps.

### Step 1a – Determine Minimum Filtration Basin Storage Volume

The storage capacity of the filtration basin above the surface of the sand filter bed should be greater than or equal to 20 percent of the WQV. This capacity is necessary in order to account for backwater effects resulting from partially clogged filter media.

$$V_{fbs} \geq 0.2 \times WQV$$

### Step 1b – SAHM Modeling for Hydromodification Management (If applicable)

Upsize the filtration basin volume as necessary based upon modeling results if implementing as a hydromodification control.

### Step 2 – Determine Filter Bed Surface Area

Surface area is the primary design parameter for the filtration basin and is a function of sand permeability, filter bed depth, hydraulic head, and filtration rate. The design filter bed area should be the larger of the minimum area required for storage and the minimum area required for flow.

- Determine minimum filter surface area required for storage ( $A_{fbs}$ )

$$A_{fbs} = V_{fbs} / d_{fbs}$$

Where:

$V_{fbs}$  = Storage volume above filter bed, ft<sup>3</sup>

$A_{fbs}$  = Filter bed surface area based on storage, ft<sup>2</sup>

$d_{fbs}$  = Depth of storage above filter bed, ft (3 ft minimum)

- Determine minimum filter surface area required for flow ( $A_{ff}$ )

$$A_{ff} = \frac{(WQV)(d_f)}{(k)(d_{fbs} + d_f)(t_f)}$$

Where:

WQV = Design Water Quality Volume, ft<sup>3</sup>

$A_{ff}$  = Filter surface area based on flow, ft<sup>2</sup>

$d_f$  = Filter bed depth, ft

$k$  = Coefficient of permeability for sand filter, ft/h (0.146 ft/h)

$d_{fbs}$  = Depth of storage above filter bed, ft

$t_f$  = Time required for runoff volume to pass through filter, hrs (48 hrs)

- Use the larger of  $A_{fbs}$  and  $A_{ff}$  as design value for sand filter bed area

### Step 3 – Design Inlet Structure

The inlet structure should spread the flow uniformly across the surface of the sand filter. Flow spreaders, weirs, or multiple orifice openings are recommended. See Figure SF-1 for an example inlet structure design.

### Step 4 – Design Filter Bed

The sand filter bed may be either of the two configurations given below. Sand bed depths are final, consolidated depths, so consolidation effects must be taken into account.

- Sand Bed with Gravel Underdrain (Figure SF-3)

The sand layer shall be a minimum depth of 18 inches and shall consist of 0.02 to 0.04-inch diameter sand. Below the sand is a layer of 0.5 to 2-inch diameter gravel that provides a minimum of two (2) inches of cover over the top of the underdrain lateral pipes. No gravel is required under the lateral pipes. A layer of geotextile fabric meeting the specifications in Table SF-2 must separate the sand and gravel and must be wrapped around the lateral pipes.

## Sand Filter

Drainage matting meeting the specifications in Table SF-2 should be placed under the laterals to provide for adequate vertical and horizontal hydraulic conductivity to the laterals.

In areas with expected high sediment loads (total suspended solids concentration  $\geq 200$  mg/L), the two-inch layer of gravel on top of the sand filter should be underlain with Enkadrain 9120™ filter fabric or equivalent meeting the specifications in Table SF-2.

- Sand Bed with Trench Underdrain (Figure SF-4)

The top layer shall be 12-18 inches of 0.02 to 0.04-inch diameter sand. Laterals shall be placed in trenches with a covering of 0.5 to 2-inch gravel and geotextile fabric (see Table SF-2). The laterals shall be underlain by a layer of drainage matting (see Table SF-2).

In areas with expected high sediment loads, see the note above about use of Enkadrain filter fabric or equivalent.

### Step 5 – Design Underdrain Piping

The underdrain piping consists of the main collector pipe(s) and perforated lateral branch pipes (see plan view in Figure SF-1). The piping should be reinforced to withstand the weight of the overburden. Internal diameters of lateral branch pipes should be six inches or greater and perforations should be 3/8 inch. Each row of perforations should contain at least six holes and the maximum spacing between rows of perforations should not exceed six inches. All piping is to be Schedule 40 polyvinyl chloride (PVC) or greater strength. The minimum slope of piping shall be 1/8 inch per foot (one (1) percent; slopes down to one-half (0.5) percent may be acceptable to the permitting agency). Access for cleaning all underdrain piping is needed.



*Sand filter in parking lot.  
City of Sacramento Department of Utilities*

*Note: Unlike the sedimentation basin, the filtration basin does not require a drawdown time for release. Thus, it is not necessary to have a specifically designed orifice for the filtration basin outlet structure.*

### Step 6 – Design Filtration Basin Liner

If the filtration basin is an earthen structure and an impermeable liner is required to protect groundwater quality, the liner shall provide a maximum permeability of  $1 \times 10^{-6}$  cm/sec (ASTM Method D-2434). If an impermeable liner is not required, then install a geotextile fabric liner that meets the specifications listed in Table SF-3 unless the basin has been excavated to bedrock.



Table SF-2. Geotextile Fabric and Drainage Matting Specifications for Sand Filters

Property	Test Method	Specifications
<b>Geotextile Fabric</b>		
Material		Non-woven geotextile fabric
Unit Weight		8 oz./yd (minimum)
Filtration Rate		0.08 in/sec (minimum)
Puncture Strength	ASTM D-751 (Modified)	125 lbs (minimum)
Mullen Burst Strength	ASTM D-751	400 psi (minimum)
Tensile Strength	ASTM-D-1682	300 lbs (minimum)
Equivalent Opening Size	US Standard Sieve	No. 80 (minimum)
<b>Drainage Matting</b>		
Material		Non-woven geotextile fabric
Unit Weight		20 oz./yd (minimum)
Flow Rate (fabric)		180 gpm/ft <sup>2</sup> (minimum)
Permeability	ASTM D-2434	12.4 x 10 <sup>-2</sup> cm/sec
Grab Strength	ASTM D-1682	Dry: Lg 90/Wd 70; Wet: Lg 95/Wd 70
Puncture Strength	COE CW-02215	42 lbs (minimum)
Mullen Burst Strength	ASTM-D-1117	400 psi (minimum)
Equivalent Opening Size	ASTM-D-1682	No. 100 (70-120)
Flow Rate (Drainage Core)	Drexel University	14 gpm/ft width
<b>Filter Fabric</b>		
Material		Non-woven geotextile fabric
Unit Weight		4.3 oz./yd (minimum)
Filtration Rate		120 gpm/ft <sup>2</sup> (minimum)
Puncture Strength	ASTM D-751 (Modified)	60 lbs (minimum)
Thickness		0.8 in (minimum)

## Sand Filter

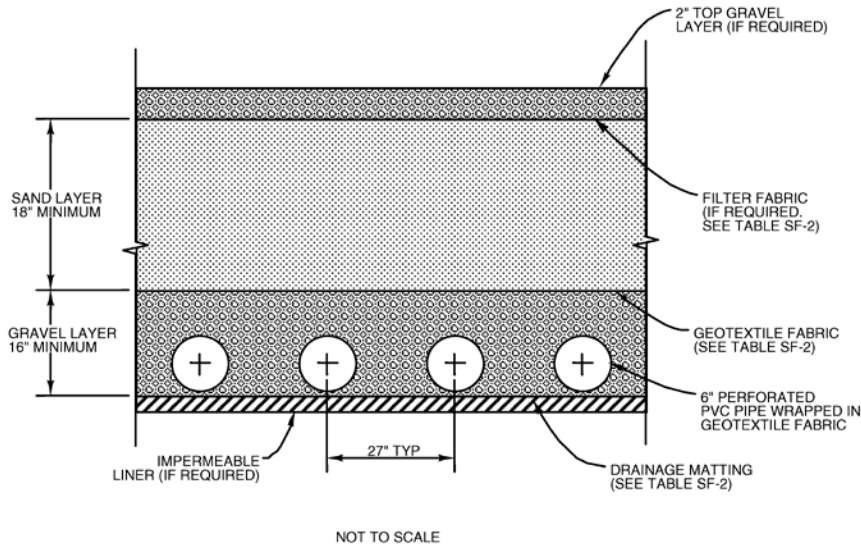

Figure SF-3. Filter Bed with Gravel Underdrain

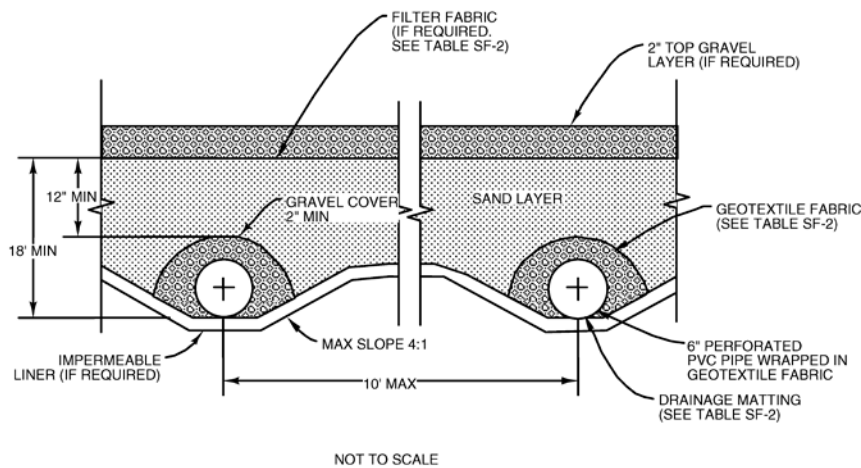

Figure SF-4. Filter Bed with Trench Underdrain

## Construction Considerations

- Divert flow around the sand filter to protect it from sediment loads during construction. If sediment does enter the facility during construction, the contractor will be required to remove soil from the unit after the entire site has been stabilized, to the satisfaction of the permitting agency inspector.
- Where underdrains are used, ensure that the minimum slope of the pipe is 0.5 (1/2) percent. Where only gravel filtered water conveyance is provided, slope the filter floor towards the weepholes at a minimum of 0.5 (1/2) percent.
- Ensure that the inverts of the notches, multiple orifices, or weirs dividing the sedimentation chamber from the filtration basin are completely level. Otherwise, water will not arrive at the

filtration basin as sheet flow, and only the downgradient end of the filtration basin will function.

- Inflow grates or slotted curbs may conform to the grade of the completed pavement as long as the filters, notches, multiple orifices, and weirs connecting the sedimentation and filter chambers are completely level.
- Level the top of the sand filter bed in the filtration basin; no slope is allowed.
- If precast concrete lids are used, provide lifting rings or threaded sockets to allow easy removal with standard lifting equipment, considering the party that will be responsible for maintenance.
- Once construction is complete, stabilize the entire contributing drainage area to the filter before allowing runoff to enter the unit.

## Long-term Maintenance

The local permitting agencies in the Sacramento area will require execution of a maintenance agreement or permit with the property owner for projects including a sand filter. Check with the local permitting agency about the timing for execution of the agreement. Such agreements will typically include requirements such as those outlined in Table SF-3. The property owner or his/her designee will be responsible for compliance. See Appendix B for additional information about maintenance requirements and sample agreement language.

*Table SF-3. Inspection and Maintenance Recommendations for Sand Filters*

Activity	Schedule
Remove trash and debris collected in the sedimentation basin inlet area to maintain the inflow capacity of the sand filter and avoid bypassing of the unit.	Before significant storm events during wet season (October 1 – April 30)
Remove cover grates or precast lids on the sedimentation basin and inspect to determine if the system is functioning properly. Inspect for standing water, sediment, grass/vegetative debris, and trash on the trash racks at the outlet pipe or elsewhere in the unit. Schedule removal of observed materials and correct any other observed problems. Sediment removal should be scheduled when the sediment occupies 10 percent of the basin volume.	Inspect quarterly during first year of operation; semiannually after first year of operation  Maintain as needed based on observations
Inspect sediment trap (if applicable) and clean when full.	Same as above
Inspect the facility after large rain events to determine whether the facility is draining completely within 48 hours. Look for discoloration of the filter, which may be an indication of clogging.	At least once during the wet season (October 1 – April 30)

## Sand Filter

Activity	Schedule
If drawdown time exceeds 48 hours, remove top two inches of sand. Restore sand layer depth to 18 inches when overall depth drops to 12 inches.	As required.
Add maintenance recommendations/methods for geotextile fabric, gravel bed, underdrains, as needed.	As needed.
Dispose of sand, gravel, or filter fabric contaminated with petroleum hydrocarbons in accordance with all applicable laws.	As required.
Reconstruct or replace the control measure when it is no longer functioning properly.	See projected lifespan in Appendix B for informational purposes.

## References

- California Stormwater Quality Association (CASQA). Stormwater Best Management Practice Handbook – New Development and Redevelopment. January 2003, revised September 2004.
- Urban Drainage and Flood Control District (UDFCD), Denver, Colorado. *Urban Drainage Criteria Manual, Volume 3 – Best Management Practices*. 1999.

Table SF-4. Design Data Summary Sheet for Sand Filter

Designer: \_\_\_\_\_ Date: \_\_\_\_\_

Company: \_\_\_\_\_

Project: \_\_\_\_\_

Location: \_\_\_\_\_

1a. Design Water Quality Volume

a. Contributing drainage area Area = \_\_\_\_\_ ft<sup>2</sup>  
 b. Water Quality Volume (based on 48 hr drawdown) WQV = \_\_\_\_\_ ft<sup>3</sup>

1b. Adjust Volume Up for Hydromodification Management (If Applicable) Based upon SAHM Modeling

a. Water Quality Volume based on SAHM modeling V = \_\_\_\_\_ ft<sup>3</sup>  
 b. SAHM Model Demonstrates Compliance with Flow Duration Standards (Yes or No) \_\_\_\_\_

2. Sedimentation Basin Volume ( $V_{sb} \geq WQV$ )  $V_{sb} =$  \_\_\_\_\_ ft<sup>3</sup>

3. Sedimentation Basin Depth ( $3 \text{ ft} \leq d_{sb} \leq 10 \text{ ft}$ )  $d_{sb} =$  \_\_\_\_\_ ft

4. Sedimentation Basin Area ( $A_{sb} = V_{sb} / d_{sb}$ )  $A_{sb} =$  \_\_\_\_\_ ft<sup>2</sup>

5. Sedimentation Basin Shape

Sedimentation Basin Length ( $L_{sb}$ )  $L_{sb} =$  \_\_\_\_\_ ft  
 Sedimentation Basin Width ( $W_{sb}$ )  $W_{sb} =$  \_\_\_\_\_ ft  
 Sedimentation Basin L:W Ratio (2:1 minimum) L:W = \_\_\_\_\_

6. Filtration Basin Storage Volume ( $V_{fbs} \geq 0.2 \times WQV$ )  $V_{fbs} =$  \_\_\_\_\_ ft<sup>3</sup>

7. Filter Bed Surface Area

a. Minimum filter surface area for storage ( $A_{fbs}$ )  
 $A_{fbs} = V_{fbs} / d_{fbs}$   
 Where  $d_{fbs} =$  Depth of storage above filter bed (3 ft min.)  $A_{fbs} =$  \_\_\_\_\_ ft<sup>2</sup>

b. Minimum filter surface area for flow ( $A_{ff}$ )  
 Sand Bed Depth ( $d_f \geq 1.5 \text{ ft}$ )  $d_f =$  \_\_\_\_\_ ft  
 Coefficient of permeability for sand ( $k = 0.146 \text{ ft/hr}$ )  $k =$  \_\_\_\_\_ ft/hr  
 Time required pass through filter ( $t_f = 40 \text{ hr}$ )  $t_f =$  \_\_\_\_\_ hr

$$A_{ff} = \frac{(WQV)(d_f)}{(k)(d_{fbs} + d_f)(t_f)}$$

$A_{ff} =$  \_\_\_\_\_ ft<sup>2</sup>

c. Final design filter bed surface area ( $A_{fb}$ )  $A_{fb} =$  \_\_\_\_\_ ft<sup>2</sup>

8. Filter Bed Design (Check Type Used)

- Sand Bed with Gravel Underdrain       Sand Bed with Trench Underdrain

THIS PAGE INTENTIONALLY LEFT BLANK

# Underground Storage

## Description

Underground storage is a practice of storing stormwater runoff in oversized pipes, detention tanks or vaults for the purpose of mitigating hydromodification impacts, and/or storing runoff for later use for irrigation of landscape areas. In some circumstances water from open bottomed or perforated storage structures can be infiltrated into the ground. Underground storage structures are typically made from concrete, metal or plastic. Many are prefabricated for rapid installation.



Photo source: City of Elk Grove

## Planning and Siting Considerations

- The maximum recommended area generating stormwater runoff to an underground storage structure is dictated by the available structure volume. The runoff volume needed for either water quality or hydromodification mitigation can be computed using the design procedure within this fact sheet.
- If infiltrating: soil types and the depth to ground water must be investigated. Open bottomed facilities are acceptable only for projects with hydrologic soil group “A” or “B”. Additionally, a minimum of 10’ must be provided from the bottom of the facility to the seasonal high water table or nearest expected rock layer.
- Permanent structures should not be constructed over the storage system. The access way for maintenance vehicles should also be clear of landscaping and other obstructions.

## Advantages

- Useful for any project subject to hydromodification management standards, but unable to comply solely through incorporation of LID measures or Treatment BMPs. Underground storage may also offer LID compliance credits if used as part of a capture and reuse system.

### Pollutant Removal Effectiveness

Sediment	*N/A
Nutrients	*N/A
Trash	*N/A
Metals	*N/A
Bacteria	*N/A
Oil and Grease	*N/A
Organics	*N/A

*\*For open bottom facilities refer to pollutant removal effectiveness of other infiltration BMP Fact Sheets within this chapter.*

*The following is a partial list of the most common target pollutants for the Sacramento area: copper, lead, mercury, pathogens, diazinon, and chlorpyrifos. For more complete information refer to:*

[http://www.waterboards.ca.gov/water\\_issues/programs/tmdl/integrated2010.shtml](http://www.waterboards.ca.gov/water_issues/programs/tmdl/integrated2010.shtml)

*Source: CASQA California Stormwater BMP Handbook, January 2003*

## Underground Storage

- Useful solution for any project seeking the following:
  - Reduction in stormwater runoff flow rate and (in the case of open bottom systems) volume.
  - Slow, regulated release of collected stormwater.
  - An acceptable option for high density areas seeking to maximize developable area
  - An acceptable alternative to the use of permeable pavement systems in complying with hydromodification management standards
  - Good option for ‘use’ of stormwater for irrigation of landscape areas.

### Limitations

- By themselves, “flow through” storage facilities only mitigate peak flow. Combined with other pretreatment features, limited improvements in water quality improvement can be achieved with flow through systems. This water quality limitation does not apply to systems sized to infiltrate the water quality volume or retain it for later use. Refer to other fact sheets for more information on the water quality benefits of infiltration BMPs.
- Upstream flooding can occur if the system is improperly designed and creates a backwater.
- Cost of storage structures can be relatively high. Tank and vault costs are estimated to range from \$10-\$15 per cubic foot of storage. Additional design complications can include utility conflicts, increased excavation, and potential temporary dewatering needs.
- Routine maintenance is required to remove sediments and debris that accumulates in the system. These systems must be designed with manhole access to accommodate regular inspection and maintenance.
- Compliance with hydromodification standards may necessitate very small discharge openings to the extent that feasibility is compromised, any orifice opening less than 0.5” is not recommended.

### General Maintenance

- Routine sweeping of the impervious drainage areas should reduce sediment loading to the underground storage area.
- During maintenance operation and access into the structure by personnel, confined space work safety procedures must be followed. Refer to: <http://www.osha.gov/Publications/osh3138.pdf>
- Periodic pumping of sediment and debris is required to have a proper functioning system.
- Sediment clean out should be done mechanically not by flushing.
- Incorporated pretreatment systems will need to be inspected and maintained on a regular basis.

## How Does Underground Storage Work?

Underground storage can mitigate the impacts of hydromodification by releasing water at rates low enough to prevent accelerated erosion of downstream channels. Underground storage designed



with an open bottom system can permit a portion of annual runoff to infiltrate, which also reduces pollutant load to receiving waters.

## Design Criteria

- System volume and sizing of primary discharge outlets is to be confirmed using SAHM or other equivalent continuous simulation tools. The design must be capable of mitigating post development flow duration within the allowable range discussed elsewhere within Chapter 5<sup>1</sup>. In many instances, primary discharge will be dictated heavily by the “low flow threshold” and could necessitate a very small outlet. In such instances, a direct maintenance access should be provided, along with other suitable measures to prevent clogging. Orifice sizes less than 0.5” are not recommended.
- Emergency overflows should be designed into the system to convey or divert excess flow, as well as regulated flow in the event of a system failure. In general emergency overflow devices or diversions should equal or exceed the capacity of inflow pipe(s) and/or contributing surface runoff. At a minimum, emergency overflow or diversions should have adequate capacity to handle the runoff from a 10 year storm, or greater if required by the local agency.

Use the Design Data Summary Sheet provided at the end of this fact sheet (Table US-2) to record design information for the permitting agency’s review.

## Design Procedure

### General Design Issues

- The designer must consider the potential loading from soil weight, vehicles and other live loads on top of the structure
- Pretreatment is recommended at the inlets to treat stormwater runoff to remove floatables and particulates.
- The systems should incorporate water tight gaskets or joints at all structural connection points.
- Maintenance access points (manholes) should be incorporated into the design. In specifying the number and location of manholes, the designer should consider the size of the facility and most likely areas for clogging and deposition of sediment, trash, and debris.
- Metal pipes should only be used in areas where soil chemistry will not negatively impact the structural integrity of the material.

### Step 1

Determine suitable location on site for underground storage such that it can effectively capture runoff from newly proposed impervious surface(s). Consider the need and ability to incorporate

---

<sup>1</sup> Refer to other applicable sections within this chapter as well as Manual Glossary for more information

## Underground Storage

water quality pretreatment in determining location of underground storage. Allow for maintenance access.

### Step 2

Determine if the system can be designed as an “open bottom” facility based upon soil type. Consult with the project geotechnical engineer to determine the need for design details such the incorporation of permeable geotextile fabric or other similar measures that can help ensure proper long term function.

### Step 3

Determine system volume, dimensions, and outlet configuration to the extent necessary to satisfy hydromodification requirements using SAHM software or other equivalent method.

### Step 4

Select underground storage material based upon dead and live loads, as well as soil chemistry. The designer should consider anticipated elevation (depth) of inflow pipes and outlet connection(s). For situations involving the use of proprietary products, consult with the manufacturer for other potential considerations.

### Step 5

Incorporate an emergency overflow into the design using bypass weirs, diversions, etc.

### Step 6

Incorporate access ways for pumping and/or mechanical removal of sediment and debris.

### Step 7

Incorporate details for water tight joints, gaskets, etc.

## Construction Considerations

- Temporary excavation requirements for underground storage can require disturbance considerably larger than the footprint structure. Shoring and bracing may be required.
- If ground water is encountered unexpectedly during construction, that is cause to reconsider use of underground storage as a stormwater management practice. Underground storage is not generally suitable for locations with high groundwater.
- For situations involving the use of proprietary products, consult with the manufacturer for other potential installation and maintenance considerations.

## Long-term Maintenance

The local permitting agencies in the Sacramento area require execution of a maintenance agreement or permit with the property owner prior to final acceptance of a private development project that

includes an underground vault. Such agreements or permits will typically include requirements such as those outlined in Table US-1. The property owner or his/her designee is responsible for compliance.

*Table US-1 Inspection and Maintenance Recommendations for Underground Storage*

Activity	Schedule
<i>Sweeping</i>	
Sweep pavement area(s) to reduce inflowing sediment load.	Minimum once annually prior to start of rainy season.
<i>Inspect Storage Chamber</i>	
Visually inspect storage chamber from maintenance access point to identify presence of standing water.	Within 48 to 72 hours after all significant runoff producing events.
Inspect storage chamber and inlet/outlet structure(s) for signs of physical deterioration and perform corrective action or replacement as necessary.	Once per year minimum.
<i>Cleanout of Sediment and Debris</i>	
Remove sediment and debris using mechanical device. Haul and dispose of accumulated sediment and debris at a suitable facility.	As required based upon visual inspection of storage chamber, or once per year minimum.
<i>Pre Treatment Areas (If Applicable)</i>	
(Refer to Other Fact Sheets Based Upon BMP Type)	

## Helpful Links

- (Confined Space Information) <http://www.osha.gov/Publications/osh3138.pdf>

## References Used to Develop This Fact Sheet

- Federal Highway Administration, *Environmental Review Toolkit: Fact Sheet – Detention Tanks and Vaults*, <http://environment.fhwa.dot.gov/ecosystems/ultraurb/3fs6.asp>, accessed 6/3/13.
- LakeSuperiorStreams.org, *Site Design Toolkit: Underground Storage*, <http://www.lakesuperiorstreams.org/stormwater/toolkit/underground.html>, accessed 6/3/13.
- United States Environmental Protection Agency, *National Menu of Best Management Practices for Storm Water Phase II*, 2002. <http://cfpub.epa.gov/npdes/stormwater/menuofbmps/index.cfm>

# Underground Storage

*Table US-2. Design Data Summary Sheet for Underground Storage*

**Designer:** \_\_\_\_\_ **Date:** \_\_\_\_\_  
**Company:** \_\_\_\_\_  
**Project:** \_\_\_\_\_  
**Location:** \_\_\_\_\_

**1. Design Water Quality Volume or Rate for Pre Treatment Area (If Applicable)**

(Refer to Applicable Fact Sheet Based Upon BMP Type)

<b>2. Determine Underlying Soil Type &amp; Ability to Incorporate Infiltration</b>	Hydrologic Soil Type (Specify A, B, C, or D)	Specify Design Infiltration Rate inches per hour (If any)
<b>3. Storage Dimensions</b>	<b>PARAMETERS MODELED IN SAHM</b>	<b>ACTUAL DESIGN ON PLANS</b>
Cross Sectional Shape (Circular, Arch, Rectangle, etc)	N/A	
Length (ft)	_____	_____
Width (ft)	_____	_____
Height (ft)	_____	_____
Total Storage Provided (ac-ft)	_____	_____
Native Infiltration Applied (inches per hour, see above)	_____	N/A
Outlet #1 Description (Specify shape, size, elevation)	_____	_____
Outlet #2 Description (Specify shape, size, elevation)	_____	_____
Outlet #3 Description (Specify shape, size, elevation)	_____	_____
SAHM Model Demonstrates Compliance with Flow Duration Standards	(Yes or No) _____	_____

**4. Specify Storage Chamber Material Type** (Specify Concrete, Metal, HDPE, etc)

\_\_\_\_\_

<b>5. Emergency Overflow</b>	<b>MODELED IN SAHM</b>	<b>ACTUAL DESIGN ON PLANS</b>
Cross Sectional Shape (Sharp Crested Weir, Broad Crested Weir, Orifice, etc)	N/A	_____
Length (ft)	_____	_____
Width (ft)	_____	_____
Height (ft)	_____	_____
Overflow Design Discharge (cfs)	_____	Hydraulic Capacity of Overflow (cfs) _____

**6. Maintenance Access Incorporated (Yes or No)**

**7. Water Tight Joints/Gaskets Specified (Yes or No)**

# Vegetated Filter Strip

## Description

A Vegetated Filter Strip is a gently sloped soil surface planted with dense, sod-forming vegetation and designed to receive and treat sheet flow runoff from adjacent surfaces. As the runoff flows through the vegetation and over the soil surface at a shallow depth, pollutants are removed by a variety of physical, chemical, and biological mechanisms, including sedimentation, filtration, adsorption, and microbial degradation and conversion.



Caltrans

## Siting Considerations

- Drainage area: 5 acres maximum per filter strip.
- Longitudinal Slope: 1% - 4%
- Terracing may be used for slopes > 4%
- Minimum length in flow direction: 25 ft.
- Minimum depth to groundwater table: 2 ft.
- Maximum ponding depth: 1 ft.
- Type A & B soils only.

## Vector Considerations

- Potential for mosquitoes due to standing water will be greatly reduced or eliminated if the strip is properly designed, constructed, and operated.

## Advantages

- Relatively inexpensive when used to replace part of a conventional storm drainage system and integrated into site landscaping.
- Attractive.
- Easy to maintain.
- Potential LEED Credits
- Credit 6.1 – Stormwater Design – Quantity Control

## Limitations

- Possible conflicts with water conservation ordinances for landscape irrigation requirements.

### POLLUTANT REMOVAL EFFECTIVENESS

Sediment	Medium
Nutrients	Low
Trash	Low
Metals	Medium
Bacteria	Low
Oil and Grease	Medium
Organics	Medium

The following is a partial list of the most common target pollutants for the Sacramento area: copper, lead, mercury, pathogens, diazinon, and chlorpyrifos. For more complete information refer to:

[http://www.waterboards.ca.gov/water\\_issues/programs/tmdl/integrated2010.shtml](http://www.waterboards.ca.gov/water_issues/programs/tmdl/integrated2010.shtml)

Source: CASQA California Stormwater BMP Handbook, January 2003

## Vegetated Filter Strip

- Not appropriate for industrial sites or locations where spills may occur.
- Removes high percentage of particulate pollutants, but not soluble pollutants.

### General Maintenance Recommendations (Low to Moderate)

- Periodically remove debris and sediment from filter strip surface.
- Repair/replace vegetation as necessary to maintain full cover and prevent erosion.
- See Table VFS-2 for additional vegetation maintenance recommendation.

## How Does a Vegetated Filter Strip Work?

A Vegetated Filter Strip is designed to allow dispersal of sheet flow over a gently sloping, densely vegetated surface. Treatment of the runoff occurs through a variety of natural mechanisms as the runoff flows through the vegetation and over the soil surface. To ensure adequate treatment, the vegetation must be dense and strong. Greater surface area and contact time promote greater runoff treatment efficiencies. The volume of runoff can be reduced through infiltration into underlying soils. See Figure VFS-1 for a typical Vegetated Filter Strip configuration.

*Other Names:* Grass filter strips, Biofilter

---

*Do not confuse a Vegetated Filter Strip with a Vegetated Swale, described elsewhere in this manual, or a Grass Buffer Strip, which is used as a low impact design strategy or for pretreatment. The latter provides only limited pollutant removal because of higher application rates, and it requires downstream treatment controls.*

---

## Planning and Siting Considerations

- Select location where site topography allows for the design of filter strips with proper slopes in flow direction.
- Integrate Vegetated Filter Strips into open space buffers, undisturbed natural areas, and other landscape areas when possible.
- For parking lot design, stalls can be shortened if tire curbs are provided around the perimeter of the filter strip and cars are allowed to overhang the filter strip.
- Irrigation is typically required to maintain viability of the filter strip vegetation. Coordinate design of general landscape irrigation system with that of the Vegetated Filter Strip, as applicable.

## Design Criteria

Design criteria for Vegetated Filter Strips are listed in Table VFS-1. Use the design data summary sheet (Table VFS-3) provided at the end of this fact sheet to record design information for review by the agency plan reviewer.

---

*Use the design data summary sheet (Table VFS-3) provided at the end of this fact sheet to record design information for review by the agency plan reviewer.*

---

Table VFS-1. Vegetated Filter Strip Design Criteria

Design Parameter	Criteria	Notes
Drainage area	≤ 5 acres	For larger areas, break up into sub-sheds of 5 acres or less with a filter strip for each.
Design flow	WQF	See Appendix E in this Design Manual.
Maximum linear application rate ( $q_a$ )	0.005 cfs/ft of width	Rate at which runoff is applied across the top width of filter strip. This rate, combined with design flow, will define the design width of the filter strip.
Minimum slope in flow direction	1%	Gentler slopes are prone to ponding of water on surface.
Maximum slope in flow direction	4%	Steeper slopes are prone to channeling.
Minimum length in flow direction	25 ft	Most treatment occurs in the first 25 feet of flow. Longer lengths will typically provide somewhat higher levels of treatment.
Vegetation height (typical)	2-4 in	Vegetation should be maintained at a height greater than the depth of flow at design flow rate but sufficiently low to prevent lodging or shading.

## Design Procedure

### Step 1 – Calculate Water Quality Flow (WQF) (Flow-Based Control Measure)

Using the Appendix E in this Design Manual, determine the contributing area and water quality design flow, WQF.

### Step 2 – Calculate minimum width of Vegetated Filter Strip ( $W_{VFS}$ )

The design minimum width of the Vegetated Filter Strip ( $W_{VFS}$ ) normal to flow direction is determined from the design WQF and the minimum application rate ( $q_a$ ), as follows:

$$W_{VFS} = (WQF)/(q_a)$$

$$W_{VFS} = (WQF)/0.005 \text{ cfs/ft (minimum)}$$

### Step 3 – Determine the minimum length of Vegetated Filter Strip in the flow direction

The length of the filter strip in the flow direction must be a minimum of 25 feet. Greater lengths are desirable, as somewhat better treatment performance can typically be expected.

---

**Early Design is Critical!**  
Vegetated Filter Strips must be located on the site plan at the earliest possible design phase when laying out the building and parking footprints and before the site grading plan is prepared.

---

## Vegetated Filter Strip

### Step 4 – Determine design slope

Slope of the filter strip surface in the direction of flow should be between one (1) percent and four (4) percent to avoid ponding and channeling of flow. Terracing may be used to maintain a slope of four (4) percent in steeper terrain.

### Step 5 – Design inlet flow distribution

Incorporate a device such as slotted curbing, modular block porous pavement, or other spreader devices at the upstream end of the filter strip to evenly distribute flow along the top width. Concentrated flow delivered to the filter strip must be distributed evenly by means of a level spreader as shown in Figure VFS-1.

### Step 6 – Select vegetation

A full, dense cover of sod-forming vegetation is necessary for the filter strip to provide adequate treatment.

Select vegetation that:

- Will be dense and strong enough to stay upright, even in flowing water;
- Has minimum need for fertilizers;
- Is not prone to pests and is consistent with IPM practices;
- Will withstand being inundated for periods of time; and
- Is consistent with local water conservation ordinance requirements.

Do not use bark or similar buoyant material in the filter strip or around drain inlets or outlets.

### Step 7 – Design outlet flow collection

Provide a means for outflow collection and conveyance (e.g., grass channel/swale, storm drain, gutter).

### Step 8 – Design irrigation system

Provide an irrigation system to maintain viability of filter strip grass. Refer to the Efficient Irrigation fact sheet elsewhere in this chapter.



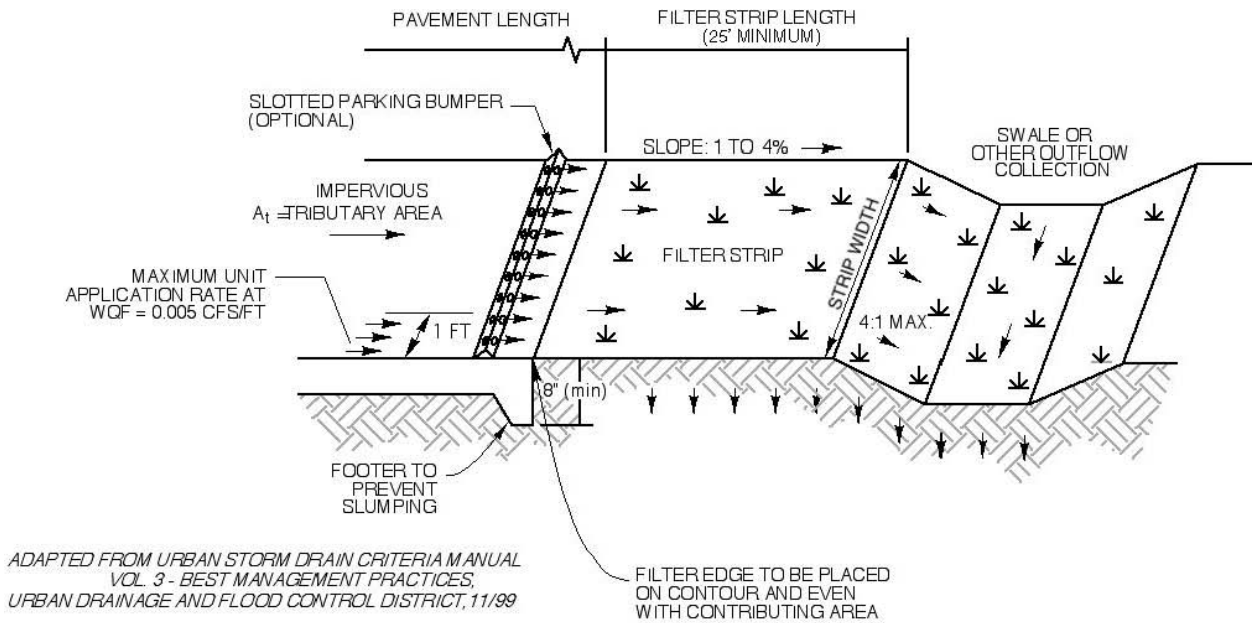

**SHEET FLOW CONTROL**

NOT TO SCALE

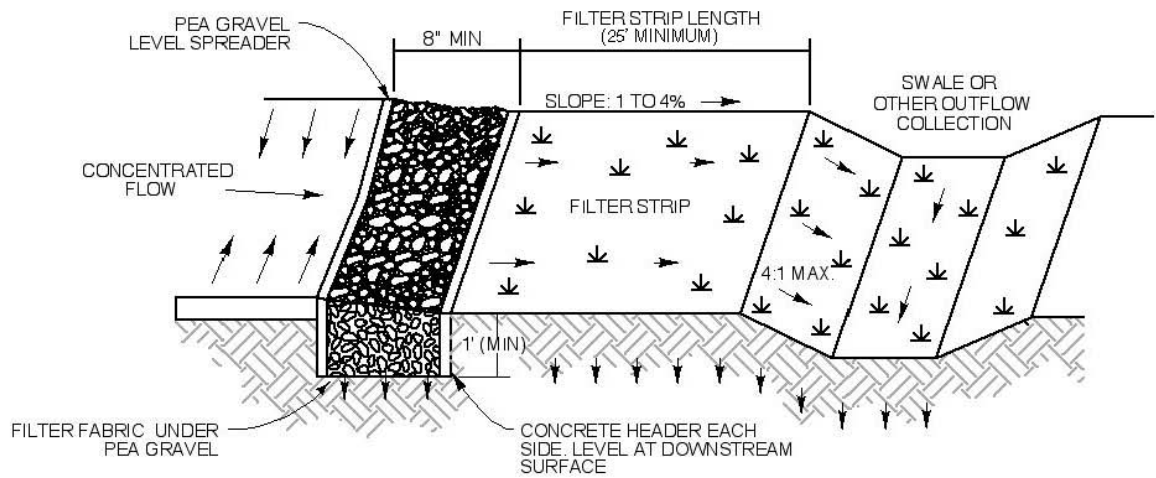

**CONCENTRATED FLOW CONTROL**

NOT TO SCALE

Figure VFS-1. Vegetated Filter Strip

## Construction Considerations

- Divert runoff (other than necessary irrigation) during the period of vegetation establishment. Where runoff diversion is not possible, cover graded and seeded areas with suitable erosion control materials.
- Install sediment controls (e.g., staked straw wattles) around the filter strip to prevent high sediment loads from entering the filter strip during ongoing upstream construction activities.
- Repair, seed, or re-plant damaged areas immediately.

## Long-term Maintenance

The local permitting agencies in the Sacramento area will require execution of a maintenance agreement or permit with the property owner for projects including a vegetated filter strip. Check with the local permitting agency about the timing for execution of the agreement. Such agreements will typically include requirements such as those outlined in Table VFS-2. The property owner or his/her designee will be responsible for compliance. See Appendix B for additional information about maintenance requirements and sample agreement language.

*Table VFS-2. Inspection and Maintenance Recommendations for Vegetated Filter Strips*

Activity	Schedule
Mow grass to maintain a height of 2 to 4 inches (typical).	As required.
Use integrated pest management (IPM) techniques to minimize use of fertilizers, pesticides and herbicides.	As required.
Remove trash and debris from the filter strip.	As required.
Inspect filter strip for signs of erosion, vegetation damage/coverage, channel formation problems, debris buildup, and excessive sedimentation on the surface of the strip. Correct problems or remove debris and sediment as soon as possible.	At least twice annually. Schedule one inspection at the end of the wet season so that summer maintenance can be scheduled to prepare filter strip for wet season. Additional inspections after periods of heavy runoff are desirable.
Remove sediment in inlet areas, the channel, culverts, and outlets whenever flow into the filter strip is retarded or blocked.	As required.
Repair ruts or holes in the strip by removing vegetation, adding and tamping suitable soil, and reseeding. Replace damaged vegetation.	As required.
Inspect filter strip for obstructions (e.g., debris accumulation, invasive vegetation) and pools of standing water that can provide mosquito-breeding habitat. Correct observed problems as soon as possible.	At least twice during the wet season after significant storms. Additional inspections after periods of heavy runoff are desirable.
Reconstruct or replace the control measure when it is no longer functioning properly.	See projected lifespan in Appendix B for informational purposes.

Table VFS-3. Design Data Summary Sheet for Vegetated Filter Strip

Designer: \_\_\_\_\_ Date: \_\_\_\_\_  
 Company: \_\_\_\_\_  
 Project: \_\_\_\_\_  
 Location: \_\_\_\_\_

1. Design Flow:  $WQF = I \times C \times A$  WQF = \_\_\_\_\_ cfs  
 $I =$  Design Intensity = 0.18 in/hr I = \_\_\_\_\_ in/hr  
 $C =$  Runoff Coefficient C = \_\_\_\_\_  
 $A =$  Contributing Drainage Area A = \_\_\_\_\_ acres

2. Design Width W<sub>VFS</sub> = \_\_\_\_\_ ft  
 $W_{VFS} = (WQF)/0.005$  cfs/ft

3. Design Length (25 ft minimum) L<sub>VFS</sub> = \_\_\_\_\_ ft

4. Design Slope (1% minimum; 4% maximum) S<sub>VFS</sub> = \_\_\_\_\_ %

5. Flow Distribution (Check type used or describe "Other")

Slotted Curbing       Level Spreader       Modular Block Porous Pavement

Other \_\_\_\_\_

6. Vegetation (describe): \_\_\_\_\_  
 \_\_\_\_\_

7. Outflow Collection (Check type used or describe "Other")

Grass Swale       Street Gutter       Storm Sewer

Underdrain Used       Other \_\_\_\_\_

Notes: \_\_\_\_\_  
 \_\_\_\_\_

THIS PAGE INTENTIONALLY LEFT BLANK

# Vegetated Swale

## Description

A vegetated swale is a wide, shallow, open channel planted with dense, sod-forming vegetation and designed to accept runoff from adjacent surfaces. As the runoff slows and travels through the vegetation and over the soil surface, pollutants are removed by a variety of physical and chemical mechanisms, including sedimentation, filtration, adsorption, and microbial degradation and conversion.

## Siting Considerations

- Drainage area: 10 acres maximum per swale.
- Longitudinal Bottom Slope: 0.5%-2.5%
- Underdrains recommended based on feedback from the project geotechnical engineer (typically for slopes less than 1%). For slopes up to 5%, check dams should be used to reduce slopes to 2.5%.
- Minimum Bottom width: 2 ft.
- Side slopes: 3:1 or flatter.
- Liners may be required in areas where swales may be impacted by hazardous materials or where spills may occur (e.g., retail gasoline outlets, auto maintenance businesses, processing/manufacturing areas).
- Surface flow into swale preferred instead of underground conveyance.

## Vector Considerations

- Potential for mosquitoes due to standing water will be greatly reduced or eliminated if the swale is properly designed, constructed, and maintained.

## Advantages

- Relatively inexpensive when used to replace part of a conventional storm drainage system and integrated into site landscaping.



Photo source unknown

Pollutant Removal Effectiveness	
Sediment	Medium
Nutrients	Low
Trash	Low
Metals*	Medium
Bacteria*	Low
Oil and Grease	Medium
Organics*	Medium

The following is a partial list of the most common target pollutants for the Sacramento area: copper, lead, mercury, pathogens, diazinon, and chlorpyrifos. For more complete information refer to:

[http://www.waterboards.ca.gov/water\\_issues/programs/tmdl/integrated2010.shtml](http://www.waterboards.ca.gov/water_issues/programs/tmdl/integrated2010.shtml)

Source: CASQA California Stormwater BMP Handbook, January 2003

## Vegetated Swale

- Provides both stormwater treatment and conveyance.
- Reduces runoff volume during small storm events.
- Attractive and easy to maintain.
- Potential LEED Credits
  - Credit 6.1 – Stormwater Design – Quantity Control
  - Credit 6.2 – Stormwater Design – Quality Control

### Limitations

- May conflict with water conservation ordinances related to landscape irrigation needs.
- May not be appropriate for industrial sites or locations where spills may occur unless liner is used to prevent infiltration.

### General Maintenance Recommendations (Low to Moderate)

- Periodically remove debris and sediment from inlets and swale.
- Repair/replace vegetation as necessary to maintain full cover and prevent erosion.
- See Table VS-2 for additional vegetation maintenance recommendation.

## How Does a Vegetated Swale Work?

A vegetated swale differs from a conventional drainage channel or roadside ditch due to the incorporation of specific features that enhance stormwater pollutant removal. A vegetated swale is designed to control flow velocities through the vegetation in the swale and to provide sufficient contact time to promote settling and filtering of the runoff flowing through it. Greater surface area and contact time promote greater runoff treatment efficiencies. The volume of runoff can also be reduced through infiltration into underlying soils.

Runoff is treated as it flows through, not over, the vegetation in a vegetated swale. Vegetation can cause considerable turbulence, resulting in energy loss and retardance of flow. To provide adequate treatment, the vegetation must be dense and strong.

*Other Names:* Grassy swale, bioswale

## Planning and Siting Considerations

- Select location where site topography allows for the design of a channel with sufficiently mild slope (unless small drop structures are used) and enough surface area to maintain non-erosive velocities in the channel.



*Alternative vegetation is encouraged but is subject to approval of local permitting agency. Parking lot swale at Elk Grove Marketplace, Elk Grove, California. Photo: CKB Environmental*

- Integrate swales into open space buffers, undisturbed natural areas, and other landscape areas when possible. Do not place in open space or wetland preserve areas where future maintenance could be prohibited.
- For parking lot design, stalls can be shortened if tire curbs are provided around the perimeter of the swale and cars are allowed to overhang the swale (see Farm Bureau photo).
- In parking lots, plan areas for pedestrians to cross swales without damaging vegetation.
- The required swale length to meet treatment criteria for a 1-acre project site is typically in the range of 75 to 100 feet. The length will vary depending on several variables, including the geometry of the swale and the runoff coefficient for the site.

---

**Early Design is Critical!**

*Vegetated swales must be located on the site plan at the earliest possible design phase when laying out the building and parking footprints and before the site grading plan is prepared.*

---



*Vegetated Swale Planted with Native Clump Grasses (note that trees should be located outside of flowline), U.S. Farm Bureau, Sacramento. Photo: City of Sacramento.*



*Roadside Swale. Photo: City of Spokane*

## Design Criteria

Design criteria for vegetated swales are listed in Table VS-1. Use the Design Data Summary Sheet provided at the end of this fact sheet (Table VS-3) to record design information for the permitting agency's review.

Table VS-1. Vegetated Swale Design Criteria

Design Parameter	Criteria	Notes
Contributing drainage area	≤ 10 acres	For larger areas, break up into sub-sheds of 10 acres or less, with a swale for each.
Water Quality design flow	WQF	See Appendix E in this Design Manual.
Roughness coefficient (n) for treatment design	0.2	Reflects the roughness associated with shallow flow through dense vegetation.
Roughness coefficient (n) for conveyance design	0.1	Reflects the roughness of swale when depth of flow is above the height of the grass. To be used to determine capacity of swale to convey peak hydraulic flows.
Minimum contact time for treatment of the WQF	7 minutes	Provide sufficient length to yield minimum contact time for the WQF
Minimum bottom width	2 ft	
Maximum bottom width	10 ft	Swales wider than 10 feet must meet additional flow spreading requirements.
Maximum side slopes	3:1	Side slopes must allow for ease of mowing. Steeper slopes may be allowed with adequate slope stabilization
Longitudinal slope	0.5-2.5%	
Check dams	As required	For longitudinal slope > 2.5% but less than 5%, and as a means of promoting more infiltration. Spacing as required to maintain maximum longitudinal bottom slope ≤ 2.5%.
Underdrains	As required	For longitudinal slope < 1.0%
Maximum depth of flow (treatment)	3-5 in	1 inch below top of vegetation
Maximum flow velocity (treatment)	1 ft/sec	Based on Manning's n - 0.20. Concentrated inlet flow must be spread.
Inlet Design/Curb cuts	≥ 12 in wide	To prevent clogging and promote flow spreading, pavement should be slightly higher than swale. Include energy dissipaters/flow spreaders such as cobble, porous concrete, or gravel at inlet.
Trees, shrubs, and plants (if applicable)		Should be located outside of the flow area.



## Design Procedure

### Step 1 – Determine the vegetated swale’s function

The vegetated swale can be designed to function as both a treatment control measure for the stormwater quality design flow and as a conveyance system to pass the peak hydraulic design flows, if the swale is located “on-line”.

---

*Record all of your calculations on the **Vegetated Swale Design Data Summary Sheet** (Table VS-3) at the end of this section. The data sheet will be checked by the agency plan review staff.*

---

### Step 2 – Calculate Water Quality Flow (WQF)

Using Appendix E in this Design Manual, determine the contributing area and stormwater quality design flow, WQF.

### Step 3 – Provide for peak hydraulic design flows

Using local hydrologic design criteria, calculate flows greater than WQF to be diverted around or flow through the swale. Design the diversion structure, if needed.

### Step 4 – Design the vegetated swale using Manning’s Equation

Swales can be trapezoidal or parabolic in shape, as illustrated in Figure VS-1. While trapezoidal channels are the most efficient for conveying flows, parabolic configurations provide good water quality treatment and may be easier to mow since they don’t have sharp breaks in slope.

Use a roughness coefficient (n) of 0.20 with Manning’s Equation to design the treatment area of a swale to account for the flow through the vegetation. To determine the capacity of the swale to convey peak hydraulic flows (for example, the 10-year event with 1 ft. of freeboard), use a roughness coefficient (n) of 0.10 with Manning’s Equation.

Manning’s Equation

$$Q = \frac{1.49}{n} \frac{A^{5/3}}{P^{2/3}} \times s^{1/2}$$

Where:

Q = WQF, (cfs)

A = Cross sectional area of flow, (ft<sup>2</sup>)

P = Wetted perimeter of flow, (ft)

s = Bottom slope in flow direction, (ft/ft)

n = Manning’s n (roughness coefficient)

For treatment design, solve Manning’s equation by trial and error to determine a bottom width that yields a flow depth of 3 to 5 inches at the design WQF and the swale geometry (i.e., side slope and s value) for the site under design.

### Step 5 – Design Inlet Controls

- For flow introduced along the length of the swale through curb cuts, provide minimum curb cut widths of 12 inches and avoid short-circuiting the swale by providing the minimum contact time of 7 minutes.
- For swales that receive direct concentrated runoff at the upstream end, provide an energy dissipater, as appropriate, and a flow spreader such as a pea gravel diaphragm flow spreader at the upstream end of the swale.

### Step 6 – Select Vegetation

A full, dense cover of sod-forming vegetation is typically recommended for vegetated swales, since most pollutant removal performance studies are based on use of grass. Alternative vegetation such as trees, shrubs and groundcovers may also be allowed; check with the local permitting agency.

Select vegetation that:

- Will be dense and strong enough to stay upright, even in flowing water and steep slopes;
- Has minimum need for fertilizers;
- Provides shading (if necessary);
- Is not prone to pests and will not require a lot of pesticide/herbicide application, consistent with any integrated pest management (IPM) practices or policies of the local permitting agency;
- Will withstand being inundated for periods of time; and
- Needs little supplemental water, consistent with local water conservation ordinances. Bunch-type grasses or grass mixes are preferred (i.e. *Sisyrinchium bellum* - blue-eyed grass).



*Vegetated swale,  
The City of Sacramento*

The Alameda Countywide C.3 Stormwater Technical Guidance handbook (<https://cleanwaterprogram.org/index.php/resources/recources/development.html>) contains a detailed plant list for consideration, although vegetation selection must be approved by the permitting agency. Do not use bark or similar buoyant material in the swale or around drain inlets or outlets.

## Construction Considerations

- Divert runoff (other than necessary irrigation) during the period of vegetation establishment. Where runoff diversion is not possible, cover graded and seeded areas with suitable erosion control materials.
- Install sediment controls (e.g., staked straw wattles) around the swale to prevent high sediment loads from entering the swale during ongoing upstream construction activities.
- Repair, seed, or re-plant damaged areas immediately.
- Apply erosion control measures as needed to stabilize side slopes and inlet areas.

## Long-term Maintenance

The local permitting agencies in the Sacramento area will require execution of a maintenance agreement or permit with the property owner for projects including a vegetated swale. Check with the local permitting agency about the timing for execution of the agreement. Such agreements will typically include requirements such as those outlined in Table VS-2. The property owner or his/her designee will be responsible for compliance. See Appendix B for additional information about maintenance requirements and sample agreement language.



Swales with rock in the flowline are **discouraged** due to high maintenance needs (including use of weed killers) and potential for mosquito breeding.

Table VS-2. Inspection and Maintenance Recommendations for Vegetated Swales

Activity	Schedule
Mow grass to maintain a height of 4 to 6 inches or above depth of flow at WQF.	As needed to maintain optimum grass height
Use integrated pest management (IPM) techniques to minimize use of fertilizers, pesticides and herbicides.	As needed.
Remove trash and debris from the swale (especially at the outlet)	As needed.
Inspect swale for signs of erosion, vegetation damage/coverage, channelization problems, debris build-up and excessive sedimentation in bottom of channel. Correct problems (e.g., remove sediment or stabilize, re-seed eroded areas) as soon as possible.	At least twice annually. Schedule one inspection at the end of the wet season so that summer maintenance can be scheduled to prepare swale for wet season. Additional inspections after periods of heavy runoff are desirable.
Remove sediment in inlet areas, channel, culverts, and outlets whenever flow into the swale is retarded or blocked.	As needed.

## Vegetated Swale

Activity	Schedule
Repair ruts or holes in the channel by removing vegetation, adding and tamping suitable soil, and reseeding. Replace damaged vegetation.	As needed.
Inspect swale for obstructions (e.g., debris accumulation, invasive vegetation) and pools of standing water that can provide mosquito breeding habitat. Correct observed problems as soon as possible.	At least twice during the wet season after significant storms. Additional inspections after periods of heavy runoff are desirable.
Reconstruct or replace the control measure when it is no longer functioning properly.	See projected lifespan in Appendix B for informational purposes.

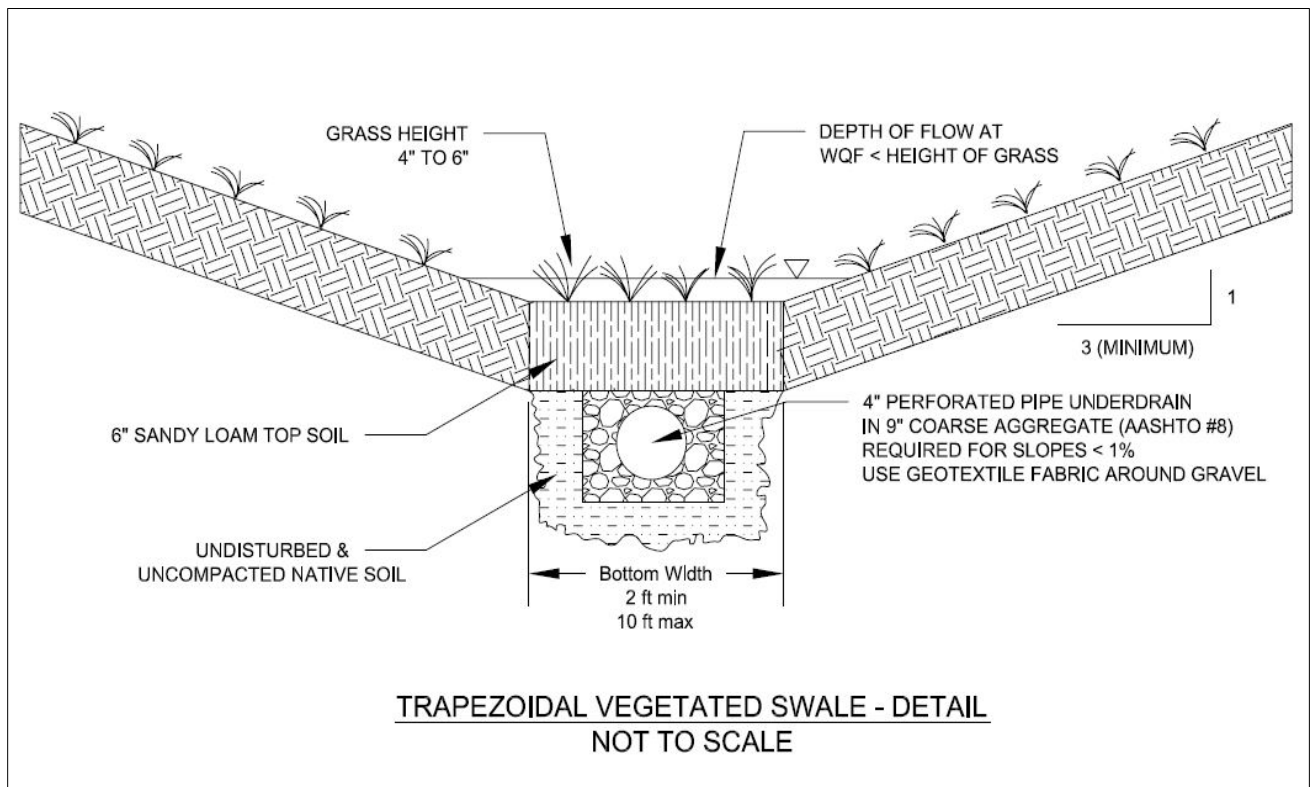
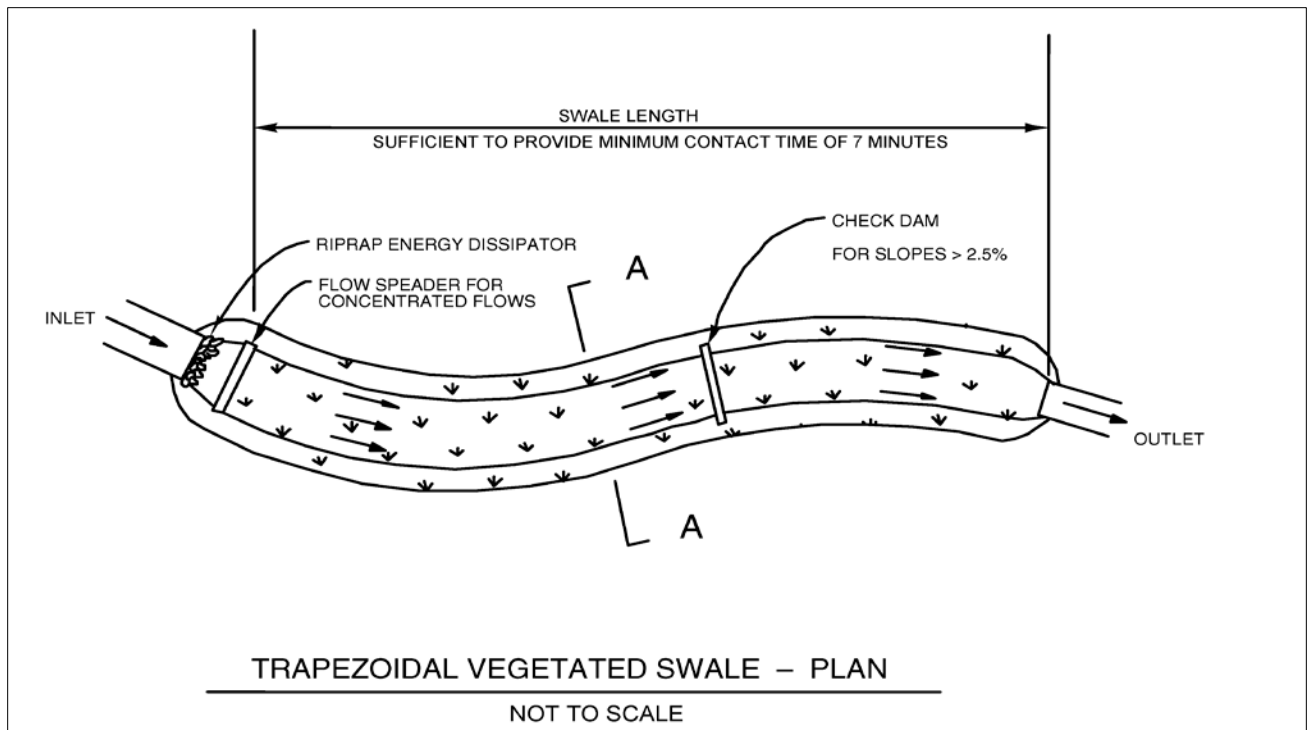

Figure VS-1. Vegetated Swale

**Note:** 6" sandy loam top soil layer only required if deemed necessary by the project geotechnical engineer to promote the swale's function.

Table VS-3. Design Data Summary Sheet for Vegetated Swale

**Designer:** \_\_\_\_\_ **Date:** \_\_\_\_\_  
**Company:** \_\_\_\_\_  
**Project:** \_\_\_\_\_  
**Location:** \_\_\_\_\_

---

**1. Design Flow:  $WQF = I \times C \times A$** 
WQF = \_\_\_\_\_ cfs  
 I = Design Intensity = 0.18 in/hr
 I = \_\_\_\_\_ in/hr  
 C = Runoff Coefficient
 C = \_\_\_\_\_  
 A = Contributing Drainage Area
 A = \_\_\_\_\_ acres

---

**2. Swale Geometry**  
 Swale Bottom Width (b)
 b = \_\_\_\_\_ Ft  
 Side slope (Z)
 Z = \_\_\_\_\_

---

**3. Depth of flow (d) at WQF (3" to 5" with Manning's n=0.20)**
d = \_\_\_\_\_ in

---

**4. Design Slope**  
 s = 1% minimum without underdrains,  
 2.5% maximum without grade controls
 s = \_\_\_\_\_ %  
 Number of grade controls required \_\_\_\_\_

---

**5. Design flow velocity (Manning's n=0.20)**
v = \_\_\_\_\_ ft/sec

---

**6. Contact Time ( $t_c = 7$  minutes maximum)**
 $t_c =$  \_\_\_\_\_ Minutes

---

**7. Design Length,  $L = (t_c) \times (\text{flow velocity}) \times 60$** 
L = \_\_\_\_\_ ft

---

**8. Vegetation (describe):** \_\_\_\_\_  
 \_\_\_\_\_

---

**9. Outflow Collection (Check type used or describe "Other")**  
 Grated Inlet
  Infiltration Trench
  Underdrain Used  
 Other \_\_\_\_\_

---

**Notes:** \_\_\_\_\_  
 \_\_\_\_\_

# Water Quality Detention Basins

## Description

A stormwater quality detention basin (also called a water quality basin or extended detention basin) is designed to hold stormwater runoff from small storms and the initial runoff (“first flush”) from larger storms for a regulated downstream release. Pollutants are removed from stormwater through gravitational settling and biological processes depending on the type of basin. There are three types of water quality detention basins:

- Wet stormwater quality detention basins (wet basins) that store a permanent pond of water
- Dry extended stormwater quality detention basins (dry-extended basins) that temporarily store stormwater runoff
- Combination (wet/dry) stormwater quality detention basins (combination basins) that combine the wet and dry basin treatment systems

Stormwater quality basins must incorporate features that treat dry-weather flows (such as irrigation runoff). Wet basins and combination basins treat the dry weather flows within the permanent pond (micropool); however, dry basin designs must include an additional feature such as a submerged gravel bed or other agency approved feature.

## Siting Considerations

- Drainage area: typically greater than 20 acres
- Longitudinal bottom slope: At least 2% in dry basins. Can undulate in wet basins.
- Side slopes: 3:1 or flatter for basin; 3:1 or steeper for permanent ponds.
- Impermeable liners may be required in areas with high groundwater.



Source: County of Sacramento, Department of Water Resources

Pollutant Removal Effectiveness		
	Dry Basin	Wet Basin
Sediment	Medium	High
Nutrients	Low	Medium
Trash	High	High
Metals	Medium	High
Bacteria	Medium	High
Oil and Grease	Medium	High
Organics	Medium	High

The following is a partial list of the most common target pollutants for the Sacramento area: copper, lead, mercury, pathogens, diazinon, and chlorpyrifos. For more complete information refer to:

[http://www.waterboards.ca.gov/water\\_issues/programs/tmdl/integrated2010.shtml](http://www.waterboards.ca.gov/water_issues/programs/tmdl/integrated2010.shtml)

Source: CASQA California Stormwater BMP Handbook, January 2003

### Vector Considerations

- Potential for mosquitoes due to standing water will be greatly reduced or eliminated if the basins and associated features are properly designed, constructed, operated and maintained.
- Permanent ponds shall be stocked with mosquito fish for vector control.

### Advantages

- May provide both stormwater quality treatment and flood control if designed for flood flows.
- Mitigate increased volume and flow impacts caused by development.
- If properly designed, constructed, and maintained, have substantial aesthetic and recreational value and provide wildlife habitat.
- Viewed as a public amenity when integrated into a park or open space setting and properly designed and landscaped.
- Wet basins: Permanent ponds can provide significant water quality improvement across a broad spectrum of constituents including dissolved nutrients.
- Wet basins: Can treat dry weather flows without the need for additional features.
- Dry basins: May be easier to maintain than wet basins.
- Potential LEED Credits
  - Credit 6.2 – Stormwater Design – Quality Control



*Photo: Bilby Road, The City of Elk Grove*

### Limitations

- May pose some safety concerns where there is public access.
- Cannot be placed on steep, unstable slopes.
- Wet basins: Need a supplemental water source to replenish and maintain the permanent pond.
- Wet basins: Are typically not permitted if routine pumping of ground or surface water would be needed to maintain the permanent pond. Check with the local permitting agency.
- Dry basins: May require more land than combination and wet ponds.

## How Does a Water Quality Detention Basin Work?

Stormwater quality detention basins allow particles and associated pollutants to settle out. Permanent ponds (micropools) may enhance pollutant removal through biological and chemical processes. The volume of runoff may also be reduced through infiltration and evaporation. Dry basins fill up during a storm event and detain the water quality volume for a period of 48 hours. Wet basins allow stormwater runoff to slowly pass through the pond displacing water from the permanent pond. Combination basins include both a permanent pond and additional storage for detaining a portion of the water quality volume for a period of 48 hours.



*Other Names:* water quality basin, extended detention basin, dry extended basin, wet ponds, wet extended-detention basins, dry ponds

## Planning and Siting Considerations

- Plan water quality basins to be aesthetically-pleasing public amenities (see Figure DB-1).
- Where possible, design water quality basins as a joint use with parks (passive recreation), open space, wildlife habitat, aesthetic amenities and/or flood control detention facilities (see Figures DB-1 and DB-2). Generally, the area within the water quality volume (WQV) is not well suited for recreation facilities such as ballparks, picnic areas and restrooms.
- Ponds present special design considerations such as the selection of appropriate vegetation and nuisance abatement in order to function properly as both a water quality control measure and a public amenity.
- Use dry basins if dry weather flows are not sufficient to maintain the permanent pond of wet and combination ponds. See Figure DB-4.
- Wet and combination basins may require a supplemental water source to maintain the permanent pond until the entire drainage shed is built out.
- Wet and combination basins require submitting water balancing calculations to ensure that the permanent pond volume will be maintained in the dry season. Use an evaporation rate of 0.45 in/day for the Sacramento area.
- May be required to include aeration and/or fountains for permanent ponds with depths greater than 6 feet.
- Place top soil within the top 12" of the basin to help support plant growth.
- Consider utilizing trees and shrubs for habitat esthetics, shade, and runoff reduction.
- Refer to the local agency drainage criteria for flood control design.
- Consider re-circulating dry-weather flows in a water feature or as irrigation water to conserve water and benefit water quality.
- Provide vehicle/equipment access for maintenance of the basins and inlet/outlet structures. May be required to include a boat ramp for harvesting of aquatic plants. Refer to the local agency for specific design criteria. Access could be combined with other uses such as walking or bicycle paths.
- Impermeable liners may be required in areas with high groundwater.
- May require approval from State Division of Safety of Dams (<http://www.water.ca.gov/damsafety>).



*Photo: Rain Garden, City of Elk Grove*

## Water Quality Detention Basins



*Figure DB-1. Park Incorporating Water Quality Detention with Wet Pond*



*Figure DB-2. Water Quality Detention Pond Incorporating Wet Pond and Natural Contours*

## Design Criteria

Design criteria for stormwater detention basins are listed in Table DB-1.

*Table DB-1. Water Quality Detention Basin Design Criteria*

Design Parameter	Criteria for Basin Type			Notes
	Dry	Wet	Combo	
Drainage area	Typically > 20 acres			
Design volume	WQV	1.25 WQV	1.125 WQV	See Figure DB-3 and Appendix E in this manual for details.
	Or as dictated greater by SAHM modeling (for projects with hydromodification requirement)			
Drawdown Time	48 hrs			See Appendix E
Depth of Basin/ Permanent Pond	NA	4 – 8 ft	4 – 8 ft	A 4 ft pond depth ensures an open water area, retards cattail growth, reduces stagnation, and allows for mosquito fish. Water deeper than 4 ft increases the residence time and results in less heating/stagnation in summer.
Basin Shape	Length 3X width (minimum)			Always maximize the distance between the inlet and outlet. Whenever possible, shape the basin to gradually expand from the inlet then gradually contract toward the outlet (e.g., teardrop).
Side slopes (H:V)	3:1 or flatter 3:1 or steeper			Basin side slopes Permanent ponds side slopes
Embankment side slope (H:V)	4:1 or flatter 3:1 or flatter			Inside Outside (without retaining wall)
Longitudinal slope/ bottom surface	Slope at least 2%	Undulate the bottom depth	Undulate the bottom depth	
Basin freeboard	1 ft			
Treatment for dry-weather flows	Submerged gravel bed	Permanent pond	Permanent pond	Other dry weather treatment features for dry basins may be approved by the permitting agency on a case-by-case basis.
Vegetation	Appropriate for extended dry periods	Appropriate for extended wet periods	Appropriate for both wet and dry periods	
Sediment Forebay Volume	5 to 10% maximum of the total design volume			Sediment forebays may not be required; check with the local permitting agency.

### Step 1a – Calculate Water Quality Volume (WQV)

Using Appendix E in this manual, determine the stormwater quality design volume, WQV, for the contributing area. See Figure DB-3 and table DB-1 for the volume requirements for dry, combination and wet basins.

### Step 1b – SAHM Modeling for Hydromodification Management (If applicable)

Upsize the water quality basin volume as necessary based upon modeling results if implementing as a hydromodification management control.

### Step 2 – Design the Basin

Design the basin to:

- Provide the required volume as determined in step 1.
- Meet criteria on Table DB-1 regarding depth, shape, side slope and longitudinal slope
- Incorporate a sediment forebay if required by the local agency. See step 3.
- Maximize residence time by placing the inlet and outlet on opposite ends of the basin. Ensuring the length is at least three times the width, as measured down the center of the flow path. For permanent ponds, incorporate additional features to maximize residence time, such as:
  - Contouring the basin bottom to baffle flows and promote mixing.
  - Using islands or peninsulas.
  - If possible, designing the deepest point to be at least 8 ft. deep.
- Incorporate access. See step 5.
- Incorporate a concrete low flow channel in dry basins (see Figures DB-4 and DB-5).
- Consider an aquatic bench with emergent vegetation around the perimeter of wet ponds and permanent pools to help with water quality and to provide a safety feature.

See Figure DB-4 for an example of a dry extended detention basin.

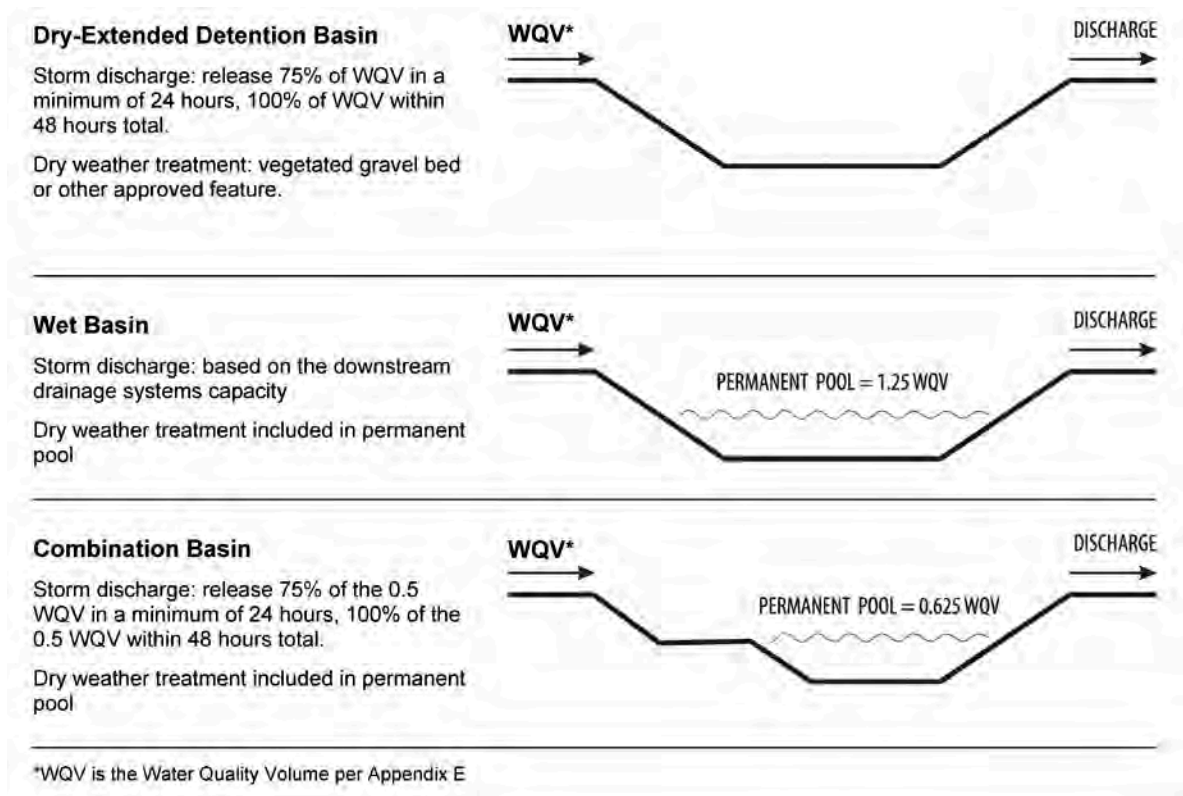

Figure DB-3. Basin Criteria to Control Stormwater Pollution

### Step 3 – Sediment Forebay

A sediment forebay may be required (check with local permitting agency) at each inflow point in order to trap sediment where it can be easily cleaned out. The forebay size should be about 5% to 10% maximum of the total design volume and designed to release in 3-5 minutes.

For easy-maintenance, design the sediment forebay(s) to include:

- An access road. See step 5 for detailed information.
- Concrete lining to prevent equipment from sinking during cleaning.
- A concrete wall to separate the forebay from the rest of the water quality basin. The concrete wall should include overflow weir allowing flows to exit at non-erosive velocities during the 2-year and 10-year frequency design storms.

### Step 4 - Design the Inlet and Outlet

#### Inlet Design

Design the inlet structure to:

- Dissipate energy of incoming flows to prevent erosion and prevent resuspension of previously deposited sediment.
- For permanent ponds, set pipe invert approximately two (2) feet from pond bottom above sediment storage.

## Water Quality Detention Basins

- Install trash/access control rack. Check with the local agencies details.
- Provide access per Step 5.

### *Outlet Design*

The goal of the outlet design criteria is to detain flows for a sufficient period of time to permit the settling of smaller sized sediments while meeting the release criteria so that storage is available for subsequent storm events. Outlets should be designed in accordance to Figure DB-6 or equal design as approved by the local agency and shall include trash racks to keep debris from clogging the outlet without interfering with the hydraulic capacity. In addition, flap gates should be installed to avoid the effects of backwater in the downstream creek or channel. The release criteria for the basins are as follows:

- Dry Basin - A dry basin is required to release 75 percent of the water quality volume in a minimum of 24 hours and the total design volume over an additional 24 hours for a total release time of 48 hours. The WQV should not be discharged too quickly or pollutant removal will be compromised.
- Wet basins - A wet basin is required to maintain the permanent pond volume while discharging based on the downstream drainage systems capacity.
- Combination basins - A combination basin is required to maintain the permanent pond volume while releasing 75 percent of the 0.5 WQV in a minimum of 24 hours and the remainder 25 percent of the 0.5 WQV over an additional 24 hours for a total release time of 48 hours.

For hydromodification management, outlet design is to be confirmed using SAHM or other equivalent continuous simulation tools

### Step 5 – Access Design

Provide a way for maintenance vehicles to access all structures and cells within the basin such as the basin bottom, sediment forebay, inlets and outlets, low flow channels and submerged gravel beds. Design access roads to have an all weather access surface, a width of 15' to 20' (check with the local permitting agency for required width) and a minimum turning radius of 40 feet. Design access ramps to be concrete or other impervious surface (check with local permitting agency) to the basin bottom with a maximum slope of 10% and a width of 15 feet. Place gates across all access ramps to discourage access.

### Step 6 – Design for Safety

Incorporate features for safety:

- Consider fencing the facility with post and cable (6" x 6" post minimum) or other approved fencing material to discourage access.
- Hinge and lock gates on structures.
- Provide gates or removable bollards across access roads.

If applicable, design the dam embankment for safety:

- Obtain approval from State Division of Safety of Dams, if required based on the size of the dam/storage volume. If that is not required, nonetheless design the embankment-spillway-outlet system to prevent catastrophic failure.
- Design the embankment not to fail during 100-year and larger storms.
- Create embankment slopes to be 3:1 or flatter for outside slopes and 4:1 or flatter for inside slopes and plant them with turf forming grasses.
- Compact embankment soils in accordance to geotechnical engineer’s specifications.
- Design spillway structures and overflows in accordance with local drainage criteria.

**Step 7- Incorporate Treatment for Dry-Weather Flows**

For wet and combination basins, the permanent pond provides treatment for dry-weather flows. For dry basins, it is necessary to provide dry-weather flow treatment such as a vegetated submerged gravel bed or other equal treatment that is approved by the local permitting agency. See Figure DB-4.

Dry weather flows vary by land use, drainage basin size, soil types and other factors. Determine dry weather design flows, Q, using the values in Table DB-2 or other criteria acceptable to the local agency.

*Table DB-2. Dry Weather Design Flows*

Basin	Area (acres)	Dry Weather Flow (MGAL/WK)	Land Use	MGAL/WK (per Ac shed)	CFS (per Ac shed)	Ac-ft/day (per Ac shed)
<i>Summary of City of Sacramento Drainage Sump Stations Used</i>						
33	684	1.07	Residential/Commercial	0.0016	0.000354	0.0007
34	687	1.25	Residential	0.0018	0.000398	0.0008
63	481	1.71	Residential	0.0036	0.000796	0.0016
66	443	1.72	Industrial	0.0039	0.000862	0.0017
67	896	3.10	Residential/Commercial	0.0035	0.000774	0.0015
69	1,115	4.50	Residential	0.0040	0.000884	0.0018
96	1,308	1.33	Mix	0.0010	0.000221	0.0004
116	197	0.30	Industrial	0.0015	0.000332	0.0007
129	1,356	3.53	Mix (mostly residential)	0.0026	0.000575	0.0011
132	2,044	8.83	Residential	0.0043	0.000950	0.0019
151	1,058	3.24	Mix	0.0031	0.000685	0.0013
152	1,479	13.60	Mix	0.0092	0.002034	0.0040
154	662	0.92	Commercial/Industrial	0.0014	0.000309	0.0006
159	573	1.48	Residential/Industrial	0.0026	0.000575	0.0011
			Average	0.0032	0.000696	0.0014
			Median	0.0029	0.000630	0.0012

## Water Quality Detention Basins

Basin	Area (acres)	Dry Weather Flow (MGAL/WK)	Land Use	MGAL/WK (per Ac shed)	CFS (per Ac shed)	Ac-ft/day (per Ac shed)
<i>Flow data from FY 12, 13, 14, 15 &amp; 16</i>						
<b>Residential and Residential/Other</b>						
33	684	1.07	Residential/Commercial	0.0016	0.000354	0.0007
34	687	1.25	Residential	0.0018	0.000398	0.0008
63	481	1.71	Residential	0.0036	0.000796	0.0016
67	896	3.10	Residential/Commercial	0.0035	0.000774	0.0015
69	1,115	4.50	Residential	0.0040	0.000884	0.0018
129	1,356	3.53	Mix (mostly residential)	0.0026	0.000575	0.0011
132	2,044	8.83	Residential	0.0043	0.000950	0.0019
159	573	1.48	Residential/Industrial	0.0026	0.000575	0.0011
			<b>Average</b>	0.0030	0.000663	0.0013
			<b>Median</b>	0.0031	0.000675	0.0013
<b>Commercial/Industrial/Mix</b>						
66	443	1.72	Industrial	0.0039	0.000860	0.0017
96	1,308	1.33	Mix	0.0010	0.000220	0.0004
116	197	0.30	Industrial	0.0015	0.000330	0.0007
151	1,058	3.24	Mix	0.0031	0.000690	0.0013
152	1,479	13.60	Mix	0.0092	0.002030	0.0040
154	662	0.92	Commercial/Industrial	0.0014	0.000310	0.0006
			<b>Average</b>	0.0034	0.000740	0.0015
			<b>Median</b>	0.0023	0.000510	0.0010
<b>Residential</b>						
34	687	1.25	Residential	0.0018	0.000398	0.0008
63	481	1.71	Residential	0.0036	0.000796	0.0016
69	1,115	4.50	Residential	0.0040	0.000884	0.0018
132	2,044	8.83	Residential	0.0043	0.000950	0.0019
			<b>Average</b>	0.0034	0.000757	0.0015
			<b>Median</b>	0.0038	0.000840	0.0017

### ***Vegetated Submerged Gravel Beds***

Vegetated submerged gravel beds can be used to reduce contaminants in dry weather flows within or outside of a dry basin (See Figure DB-4). Design vegetated submerged gravel beds so that:

- Anticipated dry weather flows pass through the gravel bed without overland flow or flooding.



- Anticipated dry weather flows pass through the gravel bed without dry out (excessive dry headspace) at the inlet zone of the bed.
- The bed remains functional in the likely event of changing hydraulic conductivity (As the bed clogs with roots and sediment, it should not flood.)
- Water levels are fully controllable through the use of inlet and outlet structures.
- The system achieves desired removal of contaminants.
- The gravel bed shall be planted with emergent plants (See Table DB-3).
- The top 3” of the gravel bed shall be above the outlet flow line.
- Gravel shall be held to 2” below the outfall flow line within a 4 foot radius of the outfall pipe.

**Basin geometry:** Choose a length-to-width ratio that results in a sufficient hydraulic gradient to push the water through the gravel bed. A length-to-width ratio of 5 to 10 is common, but other length-to-width ratios can be used provided the hydraulic gradient is adequate. (As the length-to-width ratio is increased, the linear velocity of the water passing through the gravel bed increases, the pressure drop increases, and the hydraulic gradient decreases. At some point, the hydraulic gradient is not sufficient to push the water through the gravel bed, resulting in overland flow.)

**Design Criteria:** Design using the following criteria:

- The gravel media - 1” to 1-1/2” in size.
- The bed depth –  $d = 2$  feet (The depth of media is selected by allowing consideration for bottom sediment buildup and rooting requirements of desired vegetation.)
- The design porosity of the gravel bed -  $\epsilon = 0.3$
- The effective hydraulic conductivity shall be less than 95,000 ft/day.
- Nominal hydraulic detention time through the gravel bed,  $\tau = 2$  days.

$$\text{Surface Area} = SA = L W = (\tau Q) / (d \epsilon) = (2 \text{ days})Q / (2 \text{ feet})(0.3)(86400 \text{ sec/day})$$

Where Q= dry weather design flow rate (cfs)

## Step 8 - Prepare a Landscaping Plan

Retain a certified landscape architect or wetland specialist to prepare a landscaping plan that includes:

- a planting layout showing what species to plant where
- plant sizes (e.g. seed, plug, 1-gallon container, etc.)
- planting techniques
- plant spacing
- soil amendments
- hydroseed specifications
- Irrigation specifications (which must conform to applicable local regulations)

Consider the following when choosing plants:

## Water Quality Detention Basins

- Do not plant trees at the base of any access ramps, around any inlet, outlet or culvert, or within 5 to 10 feet of a concrete structure or channel.
- Cluster trees and shrubs when possible to make mowing of basin easier.
- Trees may not be allowed on the basin floor (check with local permitting agency).
- Use native plants.
- Choose plants that are adapted to the site conditions, including the expected degree of inundation/soil moisture.
- Incorporate plants known to improve water quality.
- Where possible, specify an array of plant types, including emergent species (in channels/ponds), herbaceous species, and trees and shrubs (along the outer borders). This results in a more natural system and enhances the aesthetic and wildlife value. However, shrubs and trees should not be used for clay-lined permanent ponds or basins.

See Tables DB-3 and DB-4 for a list of suitable plants for different degrees of inundation/soil saturation. These lists are not comprehensive; other plants may be used as deemed suitable by the project's landscape architect.

Table DB-3. Plants for Areas that are Periodically Inundated

Scientific Name	Common Name	Propagation Method			Notes
		PLUG	CONTAINER STICK	SEED	
Emergent species					
<i>Carex densa</i>	Dense sedge	✓	✓		Best where soil is saturated for greater duration
<i>Carex barbarae</i>	Santa Barbara sedge	✓	✓		
<i>Cyperus eragrostis</i>	Tall faltsedge	✓	✓		
<i>Eleocharis macrostachya</i>	Creeping spikerush	✓	✓		
<i>Juncus balitcus</i>	Baltic rush	✓	✓		
<i>Juncus xiphioides</i>	Irish-leaved rush	✓	✓		
Grasses					
<i>Hordeum brachyantherum</i>	Meadow barley			✓	
<i>Leptochloa fascicularis</i>	Bearded sprangle-top			✓	
<i>Muhlenbergia rigens</i>	Deergrass			✓	
<i>Paspalum distichum</i>	Paspalum			✓	
<i>Phalaris arundinaceae</i>	Reed canary grass			✓	
<i>Phalaris lemmonii</i>	Lemmon's canary grassed			✓	
Herbaceous species					
<i>Polygonum lapathifolium</i>	Willow weed	✓	✓		Locate where soil is most apt to be saturated
<i>Polygonum punctatum</i>	Dotted smartweed	✓	✓		
<i>Verbena hastate</i>	Blue vervain		✓	✓	Locate near borders where soil dries out first

Table DB-4. Plants to Use In/Adjacent to a Permanent Pond

Scientific Name	Common Name	Propagation Method					Notes
		PLUG	CONTAINER STICK	POLE CUTTINGS	TUBER	SEED	
Aquatic species							
<i>Ceratophyllum demersum</i>	Hornwort	✓	✓				
<i>Elodea canadensis</i>	Common waterweed	✓	✓				
<i>Potamogeton pectinatus</i>	Sago pondweed				✓		
Emergent species							
<i>Carex barbarae</i>	Santa Barbara sedge	✓	✓				Best at pond border where soils are saturated/ periodically inundated
<i>Juncus balitcus</i>	Baltic rush	✓	✓				
<i>Juncus effuses</i>	Soft rush	✓	✓				
<i>Scirpus acutus</i> var. <i>Occidentalis</i>	Hard-stem bulrush	✓	✓				Adapted to water levels up to 3 feet
<i>Scirpus americanus</i>	Three square	✓	✓				Best at pond border
Grasses							
<i>Hordeum brachyantherum</i>	Meadow barley					✓	Adjacent to pond, where soils are saturated to the surface but not inundated
<i>Leptochloa fascicularis</i>	Bearded sprangle-top					✓	
<i>Paspalum distichum</i>	Paspalum					✓	
Herbaceous species							
<i>Baccharis douglasii</i>	Marsh baccharis	✓	✓				
<i>Euthamia occidentalis</i>	Western goldenrod	✓	✓				
<i>Polygonum lapathifolium</i>	Willow weed	✓	✓				Can be grown along the pond borders where soils are saturated to the surface
<i>Polygonum punctatum</i>	Dotted smartweed	✓	✓				
<i>Sagittaria latifolia</i>	Broad-leaf arrowhead	✓	✓				
Shrubs (may not be appropriate if pond is clay lined)							
<i>Baccharis salicifolia</i>	Mule fat		✓				
<i>Cephalanthus occidentalis</i>	Common buttonbush		✓				Can be grown on the pond banks; accepts greater soil saturation than the California rose

Scientific Name	Common Name	Propagation Method					Notes
		PLUG	CONTAINER STICK	POLE CUTTINGS	TUBER	SEED	
<i>Rosa californica</i>	California rose		✓				Can be grown on the pond banks, ideally where there is minimal surface soil saturation
Trees (should not be used for clay-lined permanent ponds)							
<i>Alnus rhombifolia</i>	White alder		✓				Can be grown on pond berms/ borders
<i>Populus fremontii</i>	Fremont's cottonwood		✓	✓			
<i>Salix exigua</i>	Sandbar willow		✓	✓			
<i>Salix gooddingii</i>	Goodding's black willow		✓	✓			
<i>Salix lasiolepis</i>	Arroyo willow		✓	✓			
<i>Salix laevigata</i>	Red willow		✓	✓			
<i>Salix lucida</i> var. <i>lasiandra</i>	Shining willow		✓	✓			

## Construction Considerations

- Before acceptance of the basin by the local agency, the accumulated sediment must be removed.
- See “Recommended Planting Guidelines” later in this fact sheet for information on planting techniques and recommended planting times.
- Take steps to ensure plants become established:
  - Plant emergent species bordering the permanent pond in saturated soil, so the plants will become established. Maintain the water level in the pond to allow for soil saturation or shallow inundation around the base of the plants, but avoid significant flooding and inundation of stems and leaves during the first year. Tall plugs and plantings can tolerate greater depths of inundation as long as a significant portion of the stems and leaves of the plantings remain above the water surface.
  - Provide drip irrigation for plantings in areas that will not be saturated to the surface or inundated. Irrigate as needed at least during the first two years--until the plants can survive on annual rainfall and/or groundwater.
  - Irrigate hydroseeded areas only if needed for plant establishment. Hydroseeded portions of the bank do not need irrigation in years of normal rainfall. If a period of drought occurs after hydroseeding, supplemental watering may be needed to establish germination in the first year.

## Long-term Maintenance

Regional detention basins usually will be maintained by the local agency. A long-term maintenance plan (i.e., adaptive management plan) shall be prepared by the developer/owner and approved by the local agency prior to acceptance of the basin.

If the basin will be privately maintained, the local agencies will require execution of a maintenance agreement with the property owner prior to final acceptance of a private development project, including acceptance of the water quality basin. Check with the local permitting agency about the timing for execution of the agreement. The maintenance agreement will typically include requirements such as those in Table DB-5. The property owner or his/her designee will be responsible for compliance. See Appendix B for additional information about maintenance requirements and sample agreement language.

*Table DB-5. Inspection and Maintenance Recommendations for Water Quality Detention Basins*

Activity	Schedule
Inspect the facility for needed maintenance.	Twice a year.
Remove trash and debris.	At least twice a year.
Remove sediment, debris and litter that accumulates in the sediment forebay (To clean the sediment-collection area for a wet basin, it may be necessary to drain, pump or partially drawdown the pond area.)	Every 3 to 5 years or when 6 to 12 inches have accumulated, whichever comes first. Cleanout stakes or permanent markers are recommended to track accumulation.
Remove sediment that accumulates in the concrete low flow channel (if applicable).	Annually.
Control weeds and invasive plant species. Carefully weed areas to avoid removing the native species.	Regularly during the first 2 years and then as needed.
Use integrated pest management (IPM). Refer to Landscaping fact sheet elsewhere in this chapter.	As needed.
Irrigate plants. Refer to Efficient Irrigation fact sheet elsewhere in this chapter.	As needed during the establishment period (see Construction Considerations) and during periods of drought.
Replant any bare areas. Investigate why the die-off occurred and take remedial action to correct the problem.	In the event of extensive die-off.
Harvest vegetation around the perimeter of permanent ponds so that mosquito fish are not impeded by thick vegetation.	Each summer. More frequently if required by local vector control agencies.
Harvest vegetation in channels.	As needed.
Where permitted by the Department of Fish and Game or other agency regulations, stock wet ponds with mosquito fish ( <i>Gambusia</i> spp.) to enhance natural mosquito and midge control.	As needed.
Control any erosion by redirecting or dissipating the water source. If necessary, recontour, mulch, and/or reseed.	When there are signs of erosion, including gullies, rills, and evidence of sheet erosion.
Reconstruct or replace the control measure when it is no longer functioning properly.	See projected lifespan in Appendix B for informational purposes.
Prune trees (if applicable).	Every 3-5 years.

## Recommended Planting Guidelines

### Propagation Methods

**Plugs.** Plugs are clumps of plant roots, rhizomes or tubers combined with associated soil. To propagate plants with plugs, follow these guidelines:

- Plant plugs during the fall dormant period, preferably between October 1 and November 15.
- Collect plugs from a suitable collection site in the vicinity of the constructed basins, using a qualified botanist or nursery staff. Plugs can be removed manually or salvaged with an excavator or backhoe. Collect plugs from healthy specimens free of insects, weeds and disease. Use either whole plants or plant divisions. The minimum recommended size is 1 foot x 1 foot.
- When possible, plant plugs immediately after collection. When necessary, plugs can be stored in a cool, moist, shaded location for a maximum of one day.
- Space plugs 1 foot to 6 feet apart, depending on the size of the plug. Smaller plugs can be planted at the minimum distance to promote faster spreading and cover. Plant larger plugs from cattail and bulrush species at 3 foot to 6 foot intervals.
- Prepare a hole slightly larger than the diameter of each plug and place the root system of the plug into the hole. Use a breaking bar or similar technique to create the planting hole. Manual planting with a spade is recommended for wet soils. Power augers can be used to create holes in dry soils. Alternatively, in lieu of individual holes, create a trench along the narrow axis of the pond; manually place plants at specified elevations in relation to the proximity of permanently saturated soils as shown on the planting plan.
- If the plug has an established root system, make sure the base of the stem and top of the root collar are level with the ground surface. Secure tubers to prevent floating. Place rhizomes in the soil with a slight upward angle.
- Backfill the hole or trench containing the plug(s) with soil and tamp it down to assure good soil contact and secure the plug.
- Cut back the vegetative portion of the plant to prevent water loss and wilting, and encourage the growth of roots and new shoots. Plugs of wetland plants should be grown in saturated soil.
- For wetland plants, the soil should not be allowed to dry out after planting.

**Container Stock.** When planting using container stock, follow these guidelines:

- Dig planting holes twice as wide and deep as the container size. It is recommended that container plantings receive a balanced time released fertilizer tablet that is placed at the bottom of the planting hole prior to installation of the plant.
- Space plants as shown on the planting plan.
- When planting, make sure the root collar and base of the stem are level with the adjacent soil surface. Berms for water retention and mulch can be used enhance plant establishment.
- Backfill the soil and tamp it down to assure contact with the roots. Promptly water to promote the settling of soil.

**Pole Cuttings.** Follow these guidelines when using pole cuttings:

- Collect pole cuttings from the young wood of dormant trees that are healthy and free of diseases.
- Size pole cuttings to have at least five viable nodes; to have a diameter at the base between 1/2 and 2 inches (1 inch is optimum); and to be between 2 and 4 feet long.
- Collect pole cuttings no more than 10 days prior to planting. Place them in cool water to promote swelling of the nodes, and keep the water fresh by aeration and/or by daily replacement.
- Following the production of the nodes (2-5 days), plant the pole cuttings in a rich organic medium mixed with native soil to encourage the production of a fibrous root system.
- Place pole cuttings in a hole approximately 3 feet deep (as determined by the length of the cutting—generally 75 percent of the length of the cutting should be planted beneath the soil surface). Backfill with native soil, or a rich organic medium mixed with native soil. Tamp down the soil to remove air pockets and assure soil contact with the cutting.

**Seeds.** Follow these guidelines when seeding:

- Plant seeds in the fall, preferably during the early portion of the dormant season. Time seeding to occur after plugs, container stock and pole cuttings are installed.
- Scarify the soil surface with a rake prior to seeding, taking care not to damage previously planted vegetation.
- Plant seeds at the ratios and rates specified by the supplier. The certified germination percentage should be provided by the supplier. Use seeds free of weeds and diseases.
- Broadcast seeds over the scarified planting area, using a hand-held spreader. Seed can be mixed with a slow-released fertilizer (16-20-0).
- Rake the surface to cover the seeds with about one eighth to one quarter inch of soil.



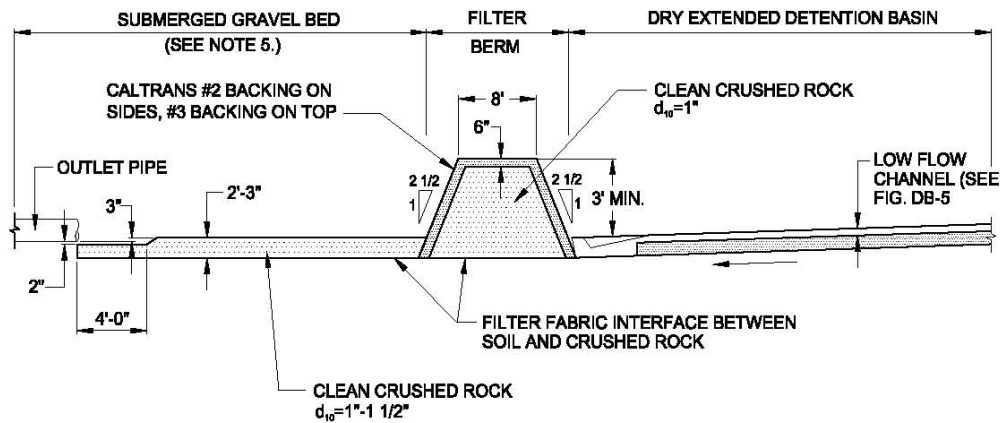
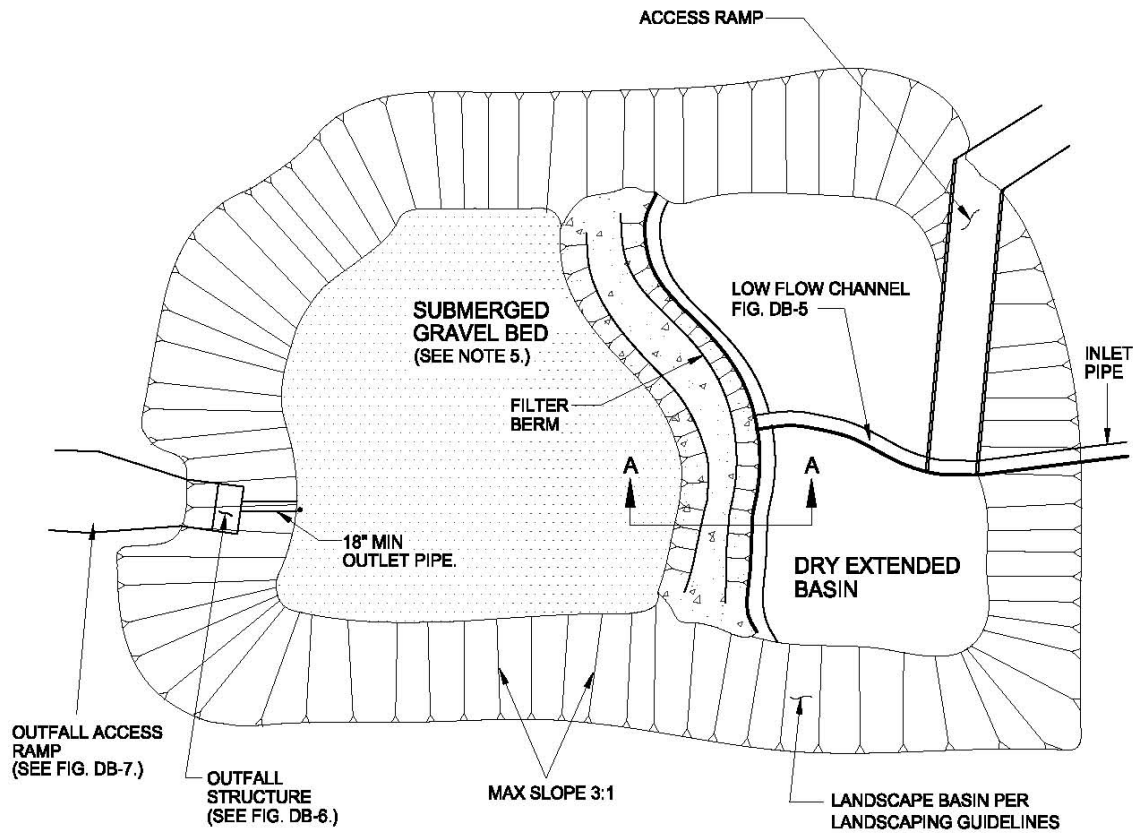

**NOTES:**

- 1.- ALL GRAVEL-SOIL INTERFACES MUST BE LINED WITH MIRAFI 400 GEOFILTER OR APPROVED EQUAL.
- 2.- TOP 3\"/>

DATE: MAY 2007

Figure DB-4. Dry Extended Stormwater Quality Detention Basin

Water Quality Detention Basins

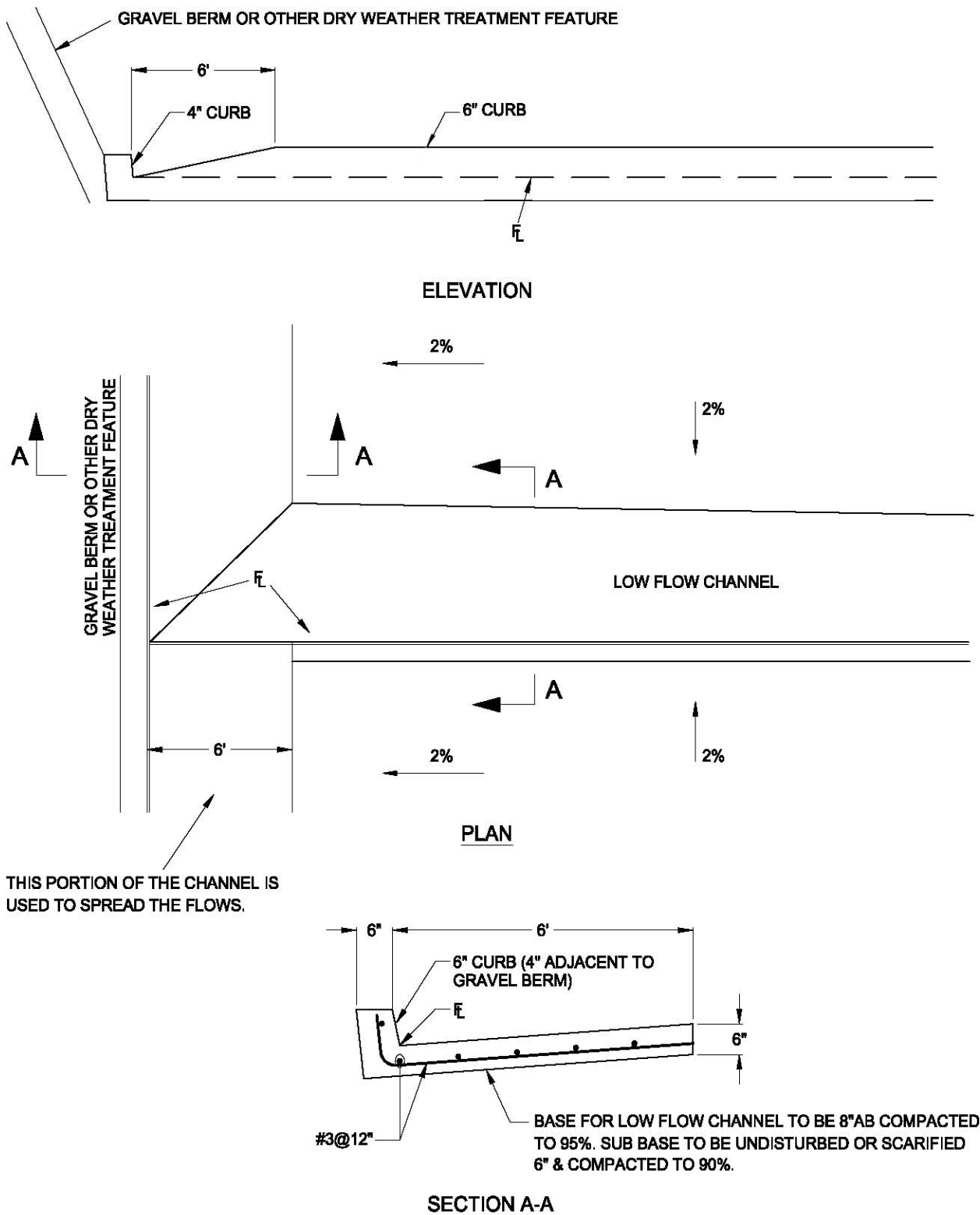

DATE: MAY 2007

Figure DB-5. Low Flow Channel

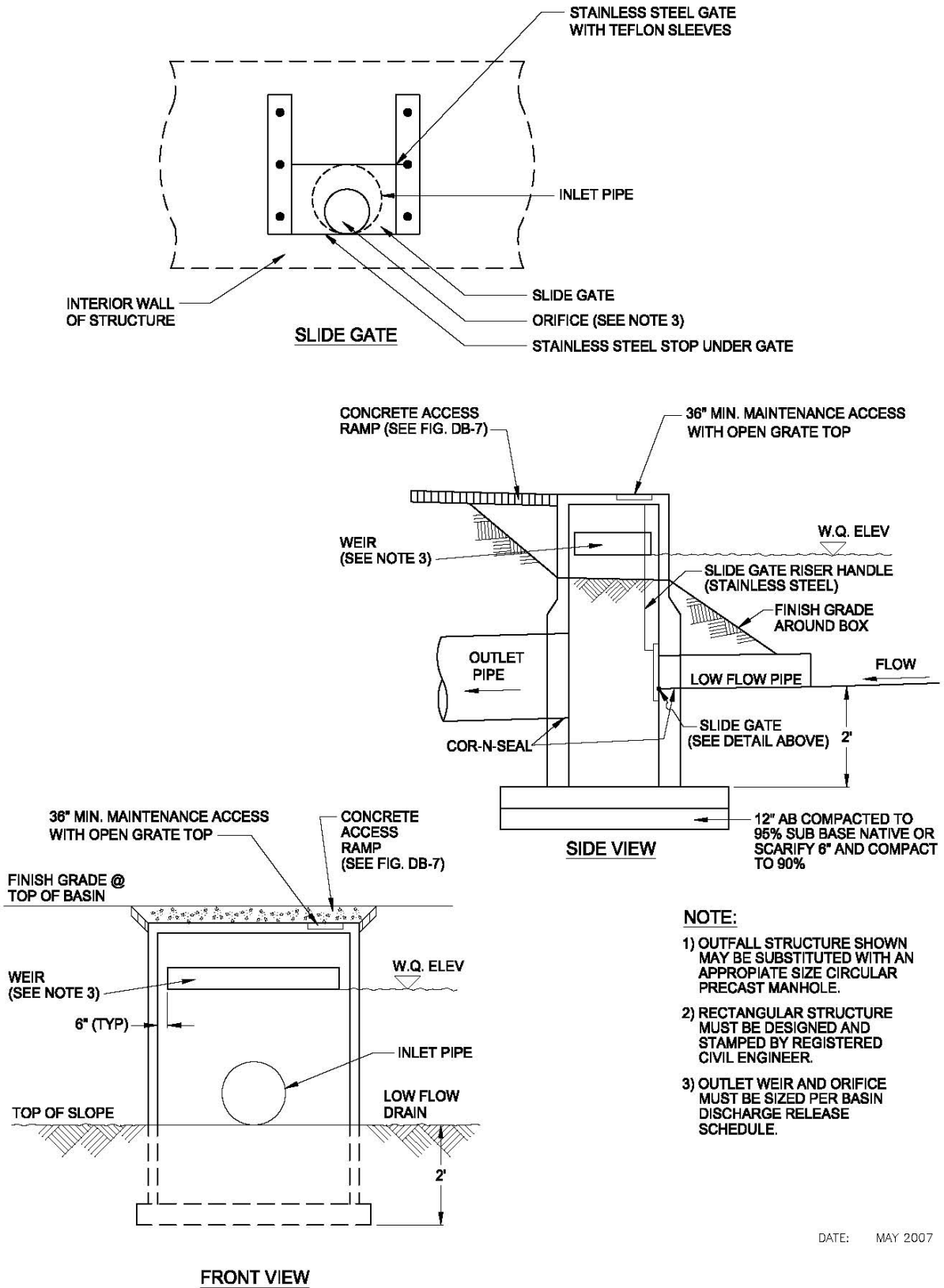

Figure DB-6. Outfall Structure

Water Quality Detention Basins

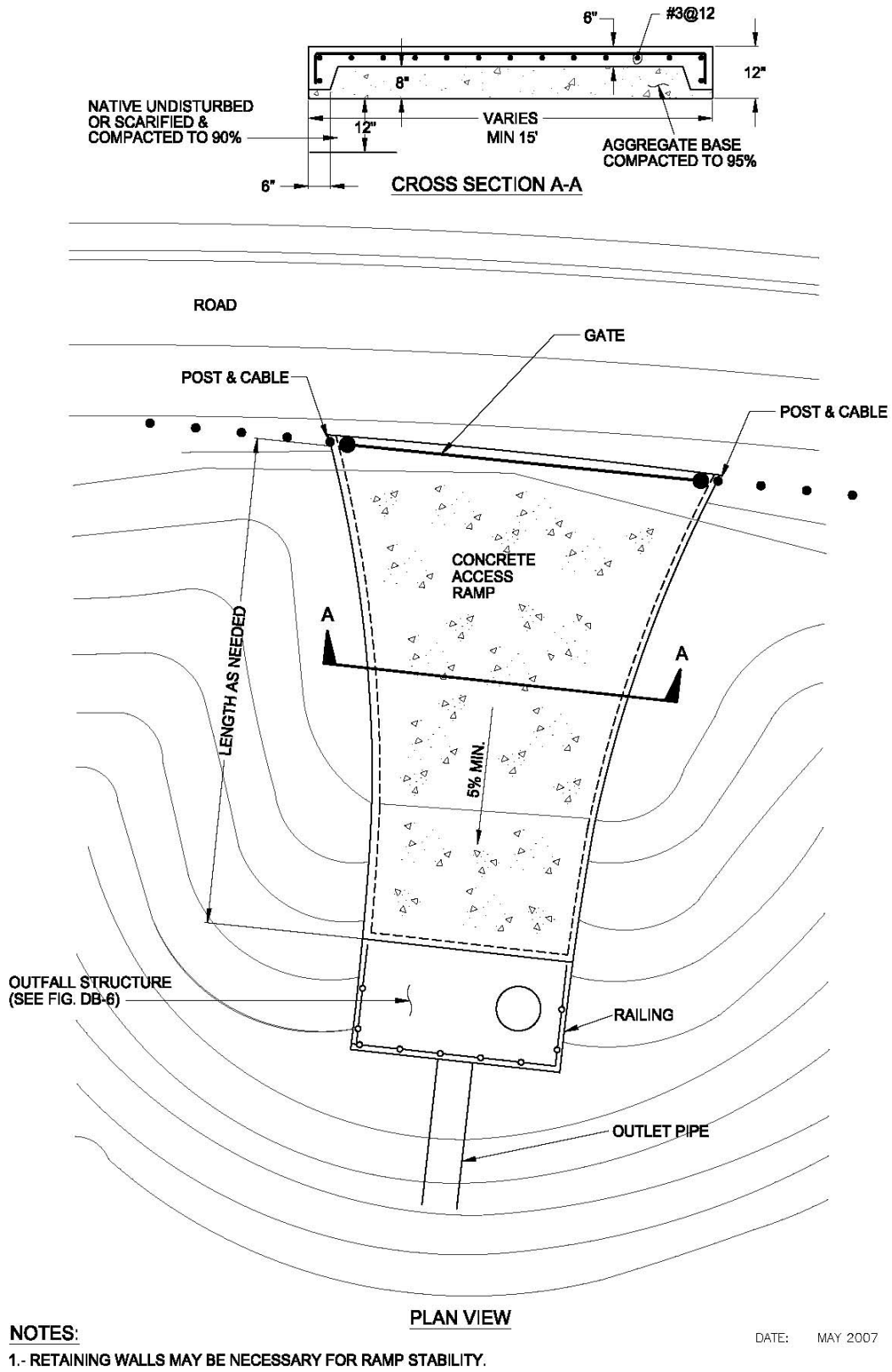

Figure DB-7. Outfall Structure Access Ramp

Table DB-6. Design Data Summary Sheet for Water Quality Detention Basin

<b>Designer:</b> _____	<b>Date:</b> _____
<b>Company:</b> _____	
<b>Project:</b> _____	
<b>Location:</b> _____	

---

**1a. Design Water Quality Volume**

a. Tributary drainage area	Area = _____	ft <sup>2</sup>
b. Water Quality Volume	WQV = _____	ft <sup>3</sup>

---

**1b. Adjust Volume Up for Hydromodification Management**  
(If Applicable) Based upon SAHM Modeling

a. Water Quality Volume based on SAHM modeling	V = _____	ft <sup>3</sup>
b. SAHM Model Demonstrates Compliance with Flow Duration Standards	(Yes or No) _____	

---

<b>2. Basin Depths and Water Surface Areas</b>	<b>ACTUAL DESIGN</b>
--	----------------------

a. For Wet and Combination Basins

Permanent pool volume (Vol <sub>pp</sub> )	Vol <sub>pp</sub> = _____	acre-ft
Average depth of permanent pool (D <sub>avg</sub> ) (4-8 ft)	D <sub>avg</sub> = _____	ft
Water surface area of permanent pool (A <sub>pp</sub> )	A <sub>pp</sub> = _____	ft <sup>2</sup>
Water surface elevation of permanent pool (WS Elev <sub>pp</sub> )	WS Elev <sub>pp</sub> = _____	ft

b. Forebay

Depth range = 2-4 ft	Depth = _____	ft
Volume range = 5-10% of WQV	Volume = _____	acre-ft
Water surface area range	WS Area = _____	ft <sup>2</sup>

---

**3. Depth of WQV and Max WS Elevation**

a. Maximum water surface area with WQV (A <sub>wqv</sub> )	A <sub>wqv</sub> = _____	ft <sup>2</sup>
b. Maximum water surface elevation with WQV (WS Elev <sub>wqv</sub> )	WS Elev <sub>wqv</sub> = _____	ft

---

**4. For Wet and Combo Basins: Determine maximum dry season inflow to maintain permanent pond in the dry season. Use Table DB-2 and an evaporation rate of 0.45 in/day for the Sacramento area.**

$Q_{inflow} = -Q_{E-P} + Q_{seepage}$	Q <sub>E-P</sub> = _____	acre-ft/mo
	Q <sub>seepage</sub> = _____	acre-ft/mo
	Q <sub>inflow</sub> = _____	acre-ft/mo

---

**5. Outlet**

a. Outlet Type:	
b. Drawdown Time	Time = _____ Hours

---

*Design Data Summary Sheet for Water Quality Detention Basin (Page 2 of 2)*

**Project:** \_\_\_\_\_

**6. Basin Shape**

Length-Width Ratio (2:1 minimum) Ratio = \_\_\_\_\_ L:W

**7. Embankment Side Slope**

a. Interior Side Slope (4:1 or flatter) Slope = \_\_\_\_\_ H:V  
b. Exterior Side Slope (3:1 or flatter) Slope = \_\_\_\_\_ H:V

**8. Maintenance Access Ramp**

a. Slope (10% maximum) Slope = \_\_\_\_\_ %  
b. Width (15 to 20 feet) Width = \_\_\_\_\_ ft

**9. Vegetation (describe)**

Native Grasses \_\_\_\_\_  
Irrigated Turf \_\_\_\_\_  
Trees \_\_\_\_\_  
Emergent Aquatic Plants (specify type/density) \_\_\_\_\_  
Other \_\_\_\_\_

**Notes:** \_\_\_\_\_  
\_\_\_\_\_

# Chapter 6. Green Streets

---

## Description

Green streets are designed in a holistic manner that minimizes impervious surfaces, emphasizes landscaped elements, includes measures for enhancing water quality, while also potentially including aspects that increase “live-ability” and/or promote alternative transportation modes. Water quality enhancement within green streets is achieved with landscape elements and/or pervious pavement systems that capture, slow, filter, and potentially infiltrate stormwater runoff into the ground. Green streets often include individual LID elements such as pervious pavement, vegetated swales, bioretention (in the form of curb extensions, rain gardens, and sidewalk planters), interceptor trees, and many others that are commonly associated with traditional development sites.

---

*Design the site to drain stormwater runoff on the landscape’s surface and minimize underground piped infrastructure. “Green” the right of way corridor by adding new trees and preserving any existing mature trees.*

---

## Applicability

- All roadway projects involving 5 acres of newly created or replaced impervious surfaces (not including overlays or routine maintenance)
- Other roadway projects involving less than 5 acres of newly created or replaced impervious surfaces seeking the following environmental benefits:
  - Mitigation of impacts from aged or inadequate storm drain infrastructure within right of way area
  - Reduction of pollutant concentration and pollutant load to receiving waters, particularly with respect to oils and grease, metals, trash, and other common roadway constituents of concern
  - Achieving aesthetic benefit and enhanced community environment
  - Air quality benefits from settlement of aerial particulate matter and reduction of low level ozone
  - Reduction of heat island effects
  - Volume reduction

Potential Elements of Green Street Design	
✓	Maximized Landscaping
✓	Minimized Impervious Area
✓	Significant Tree Canopies
✓	Runoff Reduction and Stormwater Treatment Elements
✓	Focus on Alternative Transportation Modes
✓	Combined Management of Public and Private Drainage

---

## Design Process Overview

The design procedure for green streets should follow the steps described below. In many instances, runoff reduction and stormwater treatment elements have additional detailed design procedures described within fact sheets in Chapter 5 of this manual. The reader should refer to those sections as applicable.

## Design Procedure

### Step 1 – Address Site Layout Issues

- Minimize travel lane width to the extent permissible based upon traffic safety
- Consolidate travel lanes and on street parking areas wherever feasible
- Convert unused or oversized asphalt areas next to the traveled way into landscaped stormwater management elements
- Consider the appropriateness of angled parking in lieu of traditional parallel parking spaces
- Avoid over-allotment of parking. Keep parking space count balanced with respect to landscaping area (balance number of street parking spaces and landscape planters).
- Wherever feasible, utilize vegetated elements on the surface such as vegetated swales, filter strips, or “green curbs” to convey drainage.
- Wherever feasible, incorporate trees with significant canopy area into the design. Consider canopy heights for trees near walkways, bike paths, street, drive lanes, and other features that could be adversely impacted by tree canopies.

### Step 2 – Incorporate Alternative Transportation Options

- Consider inclusion of alternative transportation elements such as bicycle lanes, bicycle racks, and preferred parking areas for carpool/vanpool participants.

### Step 3 – Choose Stormwater Facilities

#### *Vegetated Swales*

#### Good Places for Vegetated Swales:

- New residential and commercial streets
- Arterial streets and boulevards
- Within street medians on new streets

#### Why Choose Vegetated Swales?

- Widely-accepted stormwater strategy
- Simple to construct
- Relatively low-cost to implement
- Replaces underground conduits which may reduce sanitary quality



*Vegetated Swale, Colonia San Martin, County of Sacramento*



#### Potential Constraints:

- Need long, continuous spaces which can be difficult to find in retrofit conditions
- Difficult to incorporate other streetscape elements within swales (lighting, signage, etc.)
- More difficult to provide good pedestrian circulation through swales
- Often designed to be “too deep” and, as a result, are not aesthetically pleasing

Refer to Vegetated Swale BMP Fact Sheet in Chapter 5 for additional information.

#### *Bioretention within Sidewalk Planter*

##### Good Places for Sidewalk Planters:

- Streets where space is constricted

##### Why Choose Sidewalk Planters?

- Are best landscape solution for ultra-urban conditions
- Can be used with or without on-street parking depending on available space
- Can fit between other streetscape elements (trees, utilities, signage, etc.) and are highly versatile in shape and size
- Can provide both volume and flow stormwater benefits



*Sidewalk Planter - Folsom Historic District Parking*

#### Potential Constraints:

- Are generally more expensive than swales
- May only be contextually appropriate in high density urban settings
- For unlined systems, the depth to groundwater should be at least 10' below the bottom of the facility
- Liner and underdrain are required for soil types C and D

Refer to Bioretention Planter BMP Fact Sheet in Chapter 5 for additional information.

#### *Bioretention within Curb Extension Area*

##### Good Places for Curb Extensions:

- Parking zones along commercial street
- Residential settings where on-street parking is under-used

##### Why Choose Curb Extensions?

- Can significantly “green” a street with minimal investment
- Can be inexpensive to build depending on the local land use context

## Chapter 6: Green Streets

- Can be flexible in both shape and size to conform to site conditions
- Can act as a “backstop” to capture stormwater flow on steep streets
- Can narrow portions of a street and provide traffic calming benefits
- Increased cooling from landscaping and reduced heat from asphalt

### Potential Constraints:

- Generally requires the removal of on-street parking
- Can sometimes conflict with bike travel if adequate space is not allowed between edge of curb extension and a street’s travel lane
- For unlined systems, the depth to groundwater should be at least 10’ below the bottom of the facility
- Liner and underdrain are required for soil types C and D
- Vegetation must not impede sight distance



*Bioretention within curb extension area -  
Freedom Park, County of Sacramento*

Refer to Bioretention Planter BMP Fact Sheet in Chapter 5 for additional information.

### *Pervious Paving, Permeable AC and Permeable Concrete*

Good Places for using Pervious Paving, Permeable AC and Permeable Concrete:

- Low-volume streets
- Parking stalls (streets and parking lots)
- Alleys
- Residential driveways
- Sidewalks (depending on material and ADA-compliance)

### Why Choose Pervious Paving?

- Reduces the size of stormwater treatment measures
- Can be the only viable option in ultra-urban conditions

### Potential Constraints:

- Requires well-drained native soil, or other associated mitigation measures such as impervious liners and subdrain systems.
- Higher installation cost than traditional pavement



*Pervious Paving, Fair Oaks Promenade -  
Fair Oaks*

- Can be difficult to maintain and difficult to repair in small batches if using porous concrete and asphalt.
- Has limited infiltration effectiveness on street slopes over 5%. This effect can be mitigated to some extent by leveling and terracing the sub-excavation area.

Refer to Porous Pavement BMP Fact Sheet in Chapter 5 for additional information.

### *Green Gutters*

Good Places for Green Gutters:

- Residential, commercial, and arterial street frontages that have oversized wide travel lanes or “dead space” between travel lanes and the sidewalk zone

Why Choose Green Gutters?

- Can often significantly “green” a street with minimal investment
- Can be inexpensive to build depending on the local land use context
- Can help create a more walkable street environment by providing a green buffer between auto traffic and the sidewalk

Potential Constraints:

- Require a long, continuous space to effectively slow and filter stormwater pollutants
- Are very shallow and do not retain large amounts of runoff
- Can sometimes conflict with bike travel if adequate space is not allowed between edge of green gutter and a street’s travel lanes

### *Bioretention (as Rain garden)*

Good Places for Rain Gardens

- Underutilized space adjacent to streets
- Left over spaces created by angled street intersections

Why Choose Rain Gardens?

- Can often significantly “green” a space that would otherwise be leftover asphalt area
- Can be inexpensive to build depending on the amount of hardscape and pipe system used
- Can provide the greatest stormwater flow and volume benefit because of their large size
- Can provide an opportunity to incorporate small trees or large shrubs in site design
- Offer versatility in shape

Potential Constraints:

- Often more maintenance required because of their large size
- Can be difficult to find large spaces for rain gardens in ultra-urban or retrofit conditions

Refer to Bioretention Planter BMP Fact Sheet in Chapter 5 for additional information.

Table 6-1 Summary Table of LID Incorporation within Green Streets

	Vegetated Swale	Bioretention (within Sidewalk Area Planter)	Bioretention (within curb Extension Area)	Pervious Pavers/Permeable AC/Permeable Concrete	Green Gutters	Bioretention (as a Rain Garden)
Residential	✓	✓ (Site Dependent)	✓	✓	✓	✓
Commercial Main Street	✓ (Site Dependent)	✓	✓	✓	✓ (Site Dependent)	✓ (Site Dependent)
Arterial and Boulevard	✓	✓	✓		✓	

### Step 4 – Perform Final Sizing of Stormwater Facilities and Implement Detailed Design Strategies

#### *Sizing of Stormwater Facilities*

- Roadway projects consisting of 5 acres or more of new or replaced impervious surface (not including overlays or routine maintenance) should size vegetated swales, bioretention areas, and permeable pavement in accordance with the formal LID and treatment sizing standards discussed within Chapter 5 of this manual.
- Green gutters do not provide numeric credit towards the formal LID and treatment sizing standards discussed within Chapter 5 of this manual.
- For roadway projects consisting of less than 5 acres of new or replaced impervious surface, the sizing of LID stormwater and treatment facilities is at the discretion of the designer within the limits of what is practical for the individual project. However, compliance with standards discussed within Chapter 5 of this manual is encouraged.

#### *Maintaining Pedestrian Circulation within the Right of Way*

Adequate provision for pedestrian circulation should always be a major consideration of green streets. A number of typical strategies should be considered to the extent feasible and allowable by local standards. In all instances, the capture and conveyance strategy should be reviewed for compliance with the Americans with Disabilities Act (ADA).

- When on-street parking is provided adjacent to a stormwater facility, maintain a minimum 3’ clear egress zone to allow drivers and passengers to enter and exit their cars safely.
- Stormwater facilities should include reasonably frequent crossings, or “breaks” in the layout. Wherever grade differential exceeds 12” between the pedestrian circulation areas and the adjacent stormwater facilities, pedestrian safety rails should be provided based upon local agency standards. Grade differentials between 6” and 12” can be demarcated using low profile railings, low profile shrubs, raised curbs, and/or detectable warning strips.

- Separation can be provided from sidewalk planter areas through the use of raised curbs or low profile rail systems. Reasonable caution should be taken to avoid creation of tripping hazards.

#### *Control of Unintended Lateral Migration of Groundwater*

Unintended lateral flow of groundwater is a design challenge. If it is not handled in a suitable manner, the possibility to damage surrounding infrastructure (such as pavement areas, utility trenches and vaults, etc.) becomes greatly increased. In all instances, close coordination and consultation with the project geotechnical engineer should occur during the design process. The following strategies can be used to inhibit the flow of water in unintended directions:

- Impermeable liners (such as visqueen) at the sub-excavation limits of vegetated swales, bioretention areas, and permeable pavements.
- “Deepened” curbs
- Clay plugs or concrete cutoff walls within the rock portion of utility trench lines
- Various combinations or all of the above

#### *Utility Conflicts*

Utility location and maintenance needs constitute one of the greatest physical constraints in the design of green streets. The design must consider maintenance access needs, minimum cover requirements, prevention of lateral groundwater migration (discussed above), and appropriate spatial allocation for valves, vaults, and other appurtenances. The utility conflict strategy should consist of the following prioritized measures:

- Avoidance of facilities - through strategic selection and siting of stormwater facilities.
- Acceptance – when avoidance cannot be accomplished, but construction of the stormwater facility does not preclude proper function and maintenance of the utility. This approach may warrant that maintenance of the utility necessitate temporary impact, and reconstruction of the stormwater facility. For example, gas and water valve boxes have successfully been incorporated into the design of bioretention areas by protecting them within riser boxes. However, should the utility line controlled by the valve need service, temporary encroachment and restoration of the bioretention area would be needed.
- Relocation/replacement of the utility – typically a resort of last measure due to the design complications and generally cost prohibitive nature. However, this approach may be suitable in the case of aged infrastructure already identified for replacement. Incorporation of such work into a green street project may provide an opportunity to cost effectively leverage multiple objectives into one effort.

#### *Alternatives for Capture and Conveyance of Stormwater*

There are strategies that can be evaluated to capture and direct stormwater in the manner necessary to function within the context of the overall project layout. The stormwater collection strategy should consider the following to the extent feasible and allowable by local agency roadway and drainage design standards:

- Wherever feasible, priority should be given to capture stormwater in a sheet flow condition by utilizing “curbless” streets or curbs installed at an elevation flush with the edge of pavement. Flush mounted curb should be sloped towards the receiving stormwater facility.
- When a “curbless” design is not feasible, cuts in a raised curb (i.e. “curb cuts”) should be provided at the greatest possible frequency, with an 18” minimum length for each. The minimum distance between curb cuts should be calculated hydraulically based on the street slope and the size of the opening to ensure that flow will not bypass the openings. On steep streets, a low profile AC or concrete berm can be in conjunction with a longer curb cut to prevent bypass. The bottom of curb cuts should be sloped towards the stormwater facility. The outlet of curb cut areas should be stabilized with suitably sized gravel or cobbles to prevent localized scour.
- A minimum 2” drop should be provided between the roadway elevation (either at the curb cut or “curbless” edge condition) and the finished grade of the stormwater facility. This will help ensure proper performance in the event of sediment accumulation.
- Consider the use of check dams and weirs at 25’ maximum intervals to convey runoff wherever longitudinal gradient exceeds 4%

The stormwater conveyance strategy should consider the following to the extent feasible and allowable based upon local agency roadway and drainage design standards:

- Use of “non-traditional” roadway cross sections (i.e. not crowned at the center) such as “inversed crowns”, side-shed sections, and flat cross sections (well suited for permeable pavements systems)
- Using speed bumps to direct runoff in a strategic manner
- Using shallow trench drains to direct runoff in a strategic manner

### *Other Strategies*

- For project sites with hydrologic Class “C” or Class “D” soils, stormwater facilities can be sub-excavated and backfilled with select import material, gravel, and suitably designed perforated sub-drains to prevent prolonged ponding of water and associated vector hazards.
- In situations where flow enters a stormwater facility in a concentrated manner, or where the roadway generates a high volume of leaves or debris, consider use of a forebay to facilitate ease of maintenance.

## Maintenance Issues

Determination of long term maintenance responsibility is necessary to ensure optimal performance of stormwater control measures. Installation of green street stormwater control measures within the public right of way is subject to approval by the local permitting agency. Green street stormwater control measures may be subject to a maintenance agreement and/or the establishment of a maintenance funding mechanism such as Home Owners Association (HOA), Landscape and Lighting (L&L) District, or Community Facilities District (CFD). Check with the local permitting agency on the siting and long-term maintenance options.

Refer to individual LID element fact sheets in Chapter 5 for detailed inspection and maintenance procedures regarding the use of vegetated swales, vegetated strips, bioretention, and permeable pavement.

## References

- San Mateo Countywide Water Pollution Prevention Program, *San Mateo County Sustainable Green Streets and Parking Lots Design Guidebook*, January 2009.  
<http://www.flowstobay.org/documents/municipalities/sustainable%2ostreets/San%20Mateo%2oGuidebook.pdf>

THIS PAGE LEFT INTENTIONALLY BLANK



# Appendix A. Submittal Requirements

---

THIS PAGE INTENTIONALLY LEFT BLANK

**Blank - Preliminary Stormwater Quality Compliance Form  
(Sacramento County)**

*The following information is presented for example purposes only  
and may not be the current version. The other  
permitting agencies in the region may use different forms.  
Contact the local permitting agency for their submittal requirements.*

**Sacramento County Supplemental Application:  
Preliminary Stormwater Quality Compliance Form**

*This form is provided for example purposes only.*

*Check with your local permitting agency for copies of forms and procedures appropriate for your project site.*

**1) Project Information**

Applicant Name: \_\_\_\_\_ Phone Number: \_\_\_\_\_

Address: \_\_\_\_\_

Project Contact: \_\_\_\_\_ Phone Number: \_\_\_\_\_

Project name: \_\_\_\_\_ Assessor Parcel Number(s): \_\_\_\_\_

Site Address: \_\_\_\_\_

Project Category (check all that apply):

*Refer to Design Manual Table 3-2 for Priority Project Categories*

- |  |   |   |
|--|---|---|
| <input type="checkbox"/> Residential (Single Family) | <input type="checkbox"/> Retail Gasoline Outlet | <input type="checkbox"/> Hillside Development |
| <input type="checkbox"/> Residential (Multi-Family)  | <input type="checkbox"/> Restaurant             | <input type="checkbox"/> Parking Lot          |
| <input type="checkbox"/> Commercial Development      | <input type="checkbox"/> Industrial Development |   |
| <input type="checkbox"/> Automotive Repair Shop      | <input type="checkbox"/> Street/Road            |   |

Project Gross Acres: \_\_\_\_\_ Project Net Acres: \_\_\_\_\_

Existing Impervious Surface Area: \_\_\_\_\_ Proposed Impervious Surface Area: \_\_\_\_\_

Project Density (Residential Only): \_\_\_\_\_ Proposed Pervious Surface Area: \_\_\_\_\_

Watershed or Receiving Water: \_\_\_\_\_

303(d) Listed Water Bodies: \_\_\_\_\_

TMDLs: \_\_\_\_\_

**2) Source Controls** (check source control measure or applicable pollutant sources, check Design Manual Chapter 4 for more information on source control measures)

*Refer to Design Manual Table 3-2 for Requirements*

- |  |   |
|--|---|
| <input type="checkbox"/> Storm Drain Message and Signage | <input type="checkbox"/> Outdoor Work Areas           |
| <input type="checkbox"/> Fueling Areas                   | <input type="checkbox"/> Vehicle/Equipment Wash Areas |
| <input type="checkbox"/> Loading/Unloading Areas         | <input type="checkbox"/> Waste Management Areas       |
| <input type="checkbox"/> Outdoor Storage Areas           | <input type="checkbox"/> Other. Describe: _____       |

---

### 3) Low Impact Development Measures

**Refer to Design Manual Table 3-2 for Requirements**

Will LID measures be utilized for this project?  Yes  No

If yes, check selected LID measures below; attach completed worksheet (Design Manual Appendix D).

- Alternative Driveway Design
  - Disconnected Roof Drains
  - Disconnected Pavement
  - Green Roof
  - Interceptor Trees
  - Porous Pavement
  - Other. Describe: \_\_\_\_\_
- 

### 4) Stormwater Quality Treatment Requirements

**Refer to Design Manual Table 3-2 for Requirements**

Is treatment required?  Yes  No

If no, form is complete with signature. If yes, complete this section.

Indicate number of drainage subwatersheds for the site: \_\_\_\_\_

Early consideration of stormwater quality during site planning may reduce the overall cost of treatment controls. Low Impact Development (LID) methods and innovative design options can reduce the size of treatment options. In addition, early consideration allows for non-proprietary treatment options that can significantly reduce construction and maintenance costs.

---

### 5) Attach Project Overview and Stormwater Quality Narrative

Include Project description indicating nature of project (e.g., is it a newly developing site, replacement of a previously developed site, is it an infill site). Describe activities planned for site that may impact water quality such as a retail gasoline outlet as part of a development. Describe selected treatment options. Developers should keep in mind that proprietary devices require extensive maintenance by the owners of the property and do not qualify for LID credit, and should consider alternative treatment measures first. Project description should be no more than 1 page relating to stormwater quality.

Include annotated copy of Figure 3-1 of the Design Manual demonstrating applicability of stormwater quality requirements.

Include a copy of the discretionary level conditions of approval (if applicable).

---

---

**6) Attach Site Plans\* and/or Drawings Showing:**

- Existing and natural hydrologic features
- Existing and proposed drainage system (including material, size, slope, and invert elevations)
- Locations where site discharges to municipal storm drain system and/or receiving waters
- Proposed grades/contours (agency may specify contour interval)
- Proposed drainage subwatersheds including (**Refer to item #4, if treatment is required**)
  - Name of subwatershed
  - Existing amount of pervious and impervious areas
  - Proposed amount of pervious and impervious areas
  - Proposed treatment option(s) for each subwatershed
  - WQV or WQF to be treated
- Pollutant source areas including loading docks, food service areas, refuse areas, outdoor processes and storage, vehicle cleaning, repair or maintenance, fuel dispensing, equipment washing, etc.
- Proposed design features to minimize impervious areas, applicable runoff reduction techniques, innovative design, and all treatment options selected.
- Details for post-construction control measures, including the following information, where applicable:
  - Dimensions and setbacks from property lines and structures
  - Profile view, including typical cross-sections and dimensions
  - Water surface elevations/freeboard
  - Inlets, outlet structures, and release points
  - Vegetation & growing medium specifications, including provisions for temporary irrigation if needed
  - Specifications for construction materials, such as filter fabric and infiltration materials
  - Installation requirements

\*Note: Plans will not be checked for adequacy of treatment options until design review of drainage system. For information related to correct sizing and other requirements refer to *Stormwater Quality Design Manual for the Sacramento Region*.

---

**7) Attach HMP Calculations (SAHM Output Report):**

- Include SAHM output summary report demonstrating compliance with HMP flow duration criteria.

---

**8) Attach LID Credit Backup:**

- Include LID credit worksheet for either Residential or Commercial development (as applicable), or other backup documentation of LID credits.

---

**9) Attach Treatment Calculations:**

- Include miscellaneous treatment calculations for any BMPs that are not already included in item 7 (HMP calculations) or item 8 (LID Credit Spreadsheet) above.
-

**10) List Subwatersheds and Selected Stormwater Quality Measures (as required)**

Subwatershed Name	Total Subwatershed Area		Flow (cfs) or Volume (ft <sup>3</sup> )	Control Measures Selected (for Hydromodification Management, LID, and/or Treatment)
	Impervious Area	Pervious Area		

**11) Signature**

Print Name: \_\_\_\_\_ Indicate Owner or Title: \_\_\_\_\_

Signature: \_\_\_\_\_ Date: \_\_\_\_\_

\*Control measures may be those included in the *Stormwater Quality Design Manual for the Sacramento Region* or alternative measures. For projects proposing use of control measures not specified in the Design Manual, the review and approval process may take longer. Also, slight variations to design criteria stated in the manual may be approved on occasion, provided the agency determines that performance of the facility itself or other site structures/features is not compromised. For agencies in Sacramento County, proposals of alternative proprietary structural devices may be accepted if the manufacturer can satisfy the agencies' protocol or the property owner agrees to conduct a pilot scale monitoring study.

**To avoid delays, all alternative proposals should be discussed with the stormwater quality staff at the permitting agency as early as possible in the planning stages of the project, preferably at the pre-application meeting.**

**Sample (Residential) - Stormwater Quality Compliance Package  
(Sacramento County)**

*The following information is presented for example purposes only  
and may not be the current version. The other  
permitting agencies in the region may use different forms.  
Contact the local permitting agency for their submittal requirements.*



## Sutter Memorial Subdivision – Project Description

Sutter Memorial Subdivisions is a residential subdivision located in the City of Sacramento. The project is 20 acres and consists of 125 units. The development includes 275 proposed deciduous trees and approximately 35,000 square feet of bioretention running along the interior streets.

Existing development consists of several hospital buildings and associated parking lots.

The project is not located in an HMP exempt area, it is not a previously approved project, it does not discharge directly to an exempt channel, and it does not meet the infill exemption requirements.

**Sacramento County Supplemental Application:  
Preliminary Stormwater Quality Compliance Form**

*This form is provided for example purposes only.*

*Check with your local permitting agency for copies of forms and procedures appropriate for your project site.*

**1) Project Information**

Applicant Name: Sutter & Associates Phone Number: 916-123-4567  
Address: 1234 1<sup>st</sup> Street, Sacramento, CA 95818  
Project Contact: Jim Anderson Phone Number: 916-987-6543  
Project name: Sutter Memorial Assessor Parcel Number(s): 004-0010-006  
Site Address: 5105 F Street, Sacramento, CA 95818

Project Category (check all that apply):

***Refer to Design Manual Table 3-2 for Priority Project Categories***

- |   |   |   |
|---|---|---|
| <input checked="" type="checkbox"/> Residential (Single Family) | <input type="checkbox"/> Retail Gasoline Outlet | <input type="checkbox"/> Hillside Development |
| <input type="checkbox"/> Residential (Multi-Family)             | <input type="checkbox"/> Restaurant             | <input type="checkbox"/> Parking Lot          |
| <input type="checkbox"/> Commercial Development                 | <input type="checkbox"/> Industrial Development |   |
| <input type="checkbox"/> Automotive Repair Shop                 | <input checked="" type="checkbox"/> Street/Road |   |

Project Gross Acres: 20 Project Net Acres: 20  
Existing Impervious Surface Area: 0 Proposed Impervious Surface Area: 10  
Project Density (Residential Only): 7 DUA Proposed Pervious Surface Area: 10  
Watershed or Receiving Water: Laguna Creek  
303(d) Listed Water Bodies: none  
TMDLs: none

**2) Source Controls** (check source control measure or applicable pollutant sources, check Design Manual Chapter 4 for more information on source control measures)

***Refer to Design Manual Table 3-2 for Requirements***

- |   |   |
|---|---|
| <input checked="" type="checkbox"/> Storm Drain Message and Signage | <input type="checkbox"/> Outdoor Work Areas           |
| <input type="checkbox"/> Fueling Areas                              | <input type="checkbox"/> Vehicle/Equipment Wash Areas |
| <input type="checkbox"/> Loading/Unloading Areas                    | <input type="checkbox"/> Waste Management Areas       |
| <input type="checkbox"/> Outdoor Storage Areas                      | <input type="checkbox"/> Other. Describe: _____       |

---

### 3) Low Impact Development Measures

**Refer to Design Manual Table 3-2 for Requirements**

Will LID measures be utilized for this project?       Yes       No

If yes, check selected LID measures below; attach completed worksheet (Design Manual Appendix D).

- Alternative Driveway Design
  - Disconnected Roof Drains
  - Disconnected Pavement
  - Green Roof
  - Interceptor Trees
  - Porous Pavement
  - Other. Describe: \_\_\_\_\_
- 

### 4) Stormwater Quality Treatment Requirements

**Refer to Design Manual Table 3-2 for Requirements**

Is treatment required?       Yes       No

If no, form is complete with signature. If yes, complete this section.

Indicate number of drainage subwatersheds for 1  
the site: \_\_\_\_\_

Early consideration of stormwater quality during site planning may reduce the overall cost of treatment controls. Low Impact Development (LID) methods and innovative design options can reduce the size of treatment options. In addition, early consideration allows for non-proprietary treatment options that can significantly reduce construction and maintenance costs.

---

### 5) Attach Project Overview and Stormwater Quality Narrative

Include Project description indicating nature of project (e.g., is it a newly developing site, replacement of a previously developed site, is it an infill site). Describe activities planned for site that may impact water quality such as a retail gasoline outlet as part of a development. Describe selected treatment options. Developers should keep in mind that proprietary devices require extensive maintenance by the owners of the property and do not qualify for LID credit, and should consider alternative treatment measures first. Project description should be no more than 1 page relating to stormwater quality.

Include annotated copy of Figure 3-1 of the Design Manual demonstrating applicability of stormwater quality requirements.

Include a copy of the discretionary level conditions of approval (if applicable).

---

---

**6) Attach Site Plans\* and/or Drawings Showing:**

- Existing and natural hydrologic features
- Existing and proposed drainage system (including material, size, slope, and invert elevations)
- Locations where site discharges to municipal storm drain system and/or receiving waters
- Proposed grades/contours (agency may specify contour interval)
- Proposed drainage subwatersheds including (**Refer to item #4, if treatment is required**)
  - Name of subwatershed
  - Existing amount of pervious and impervious areas
  - Proposed amount of pervious and impervious areas
  - Proposed treatment option(s) for each subwatershed
  - WQV or WQF to be treated
- Pollutant source areas including loading docks, food service areas, refuse areas, outdoor processes and storage, vehicle cleaning, repair or maintenance, fuel dispensing, equipment washing, etc.
- Proposed design features to minimize impervious areas, applicable runoff reduction techniques, innovative design, and all treatment options selected.
- Details for post-construction control measures, including the following information, where applicable:
  - Dimensions and setbacks from property lines and structures
  - Profile view, including typical cross-sections and dimensions
  - Water surface elevations/freeboard
  - Inlets, outlet structures, and release points
  - Vegetation & growing medium specifications, including provisions for temporary irrigation if needed
  - Specifications for construction materials, such as filter fabric and infiltration materials
  - Installation requirements

\*Note: Plans will not be checked for adequacy of treatment options until design review of drainage system. For information related to correct sizing and other requirements refer to *Stormwater Quality Design Manual for the Sacramento Region*.

---

**7) Attach HMP Calculations (SAHM Output Report):**

- Include SAHM output summary report demonstrating compliance with HMP flow duration criteria.

---

**8) Attach LID Credit Backup:**

- Include LID credit worksheet for either Residential or Commercial development (as applicable), or other backup documentation of LID credits.

---

**9) Attach Treatment Calculations:**

- Include miscellaneous treatment calculations for any BMPs that are not already included in item 7 (HMP calculations) or item 8 (LID Credit Worksheet) above.
-

**10) List Subwatersheds and Selected Stormwater Quality Measures (as required)**

Subwatershed Name	Total Subwatershed Area		Flow (cfs) or Volume (ft <sup>3</sup> )	Control Measures Selected (for Hydromodification Management, LID, and/or Treatment)
	Impervious Area	Pervious Area		
1	14		32,525 ft <sup>3</sup>	Bioretention
	10	4		

**11) Signature**

Print Name: Jim Anderson Indicate Owner or Title: Owner

Signature: *Jim Anderson* Date: 8-14-2013

\*Control measures may be those included in the *Stormwater Quality Design Manual for the Sacramento Region* or alternative measures. For projects proposing use of control measures not specified in the Design Manual, the review and approval process may take longer. Also, slight variations to design criteria stated in the manual may be approved on occasion, provided the agency determines that performance of the facility itself or other site structures/features is not compromised. For agencies in Sacramento County, proposals of alternative proprietary structural devices may be accepted if the manufacturer can satisfy the agencies' protocol or the property owner agrees to conduct a pilot scale monitoring study.

**To avoid delays, all alternative proposals should be discussed with the stormwater quality staff at the permitting agency as early as possible in the planning stages of the project, preferably at the pre-application meeting.**

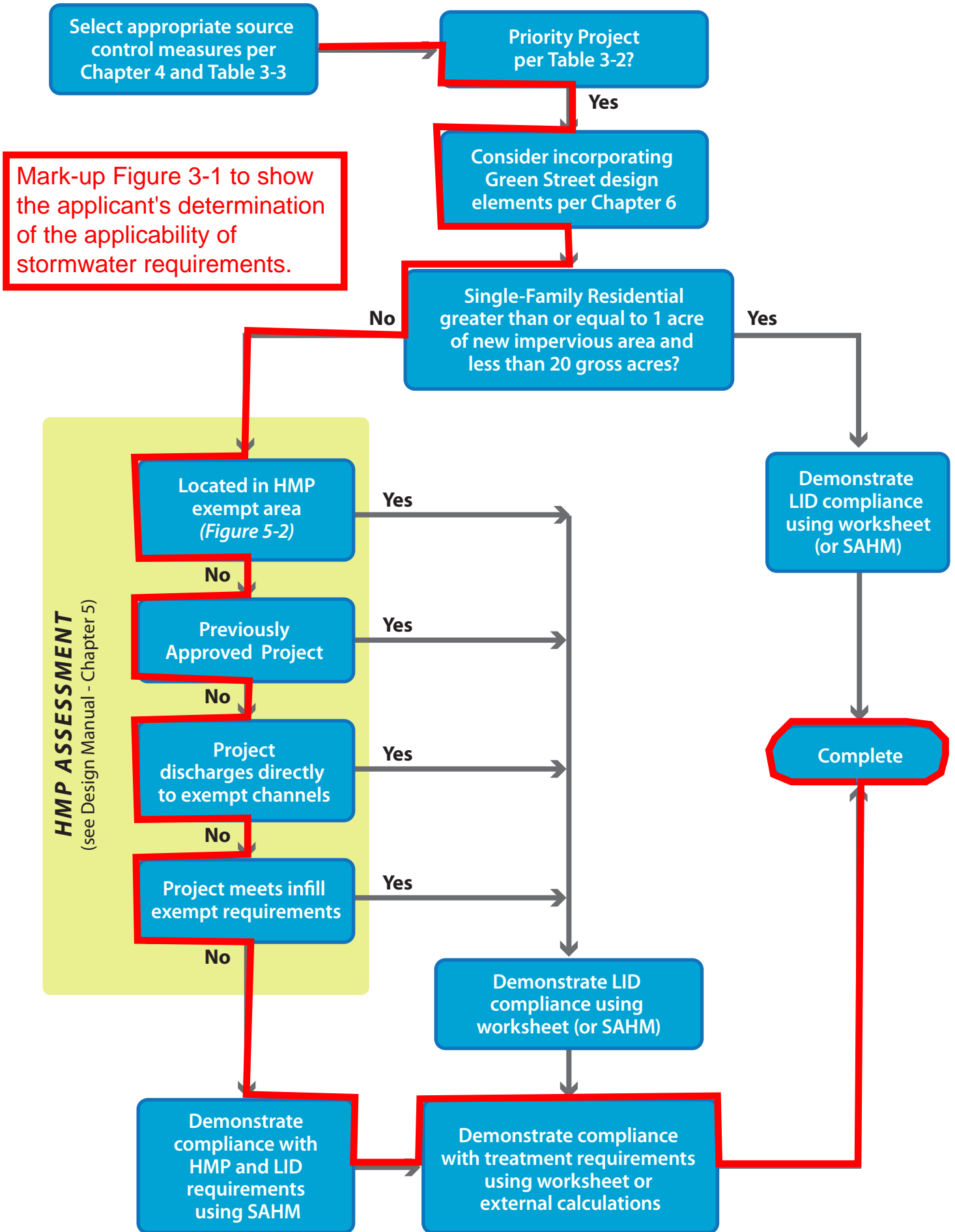



**NOTE: All roofs and sidewalks must be disconnected**

**Bioretention - 43,848 SF**

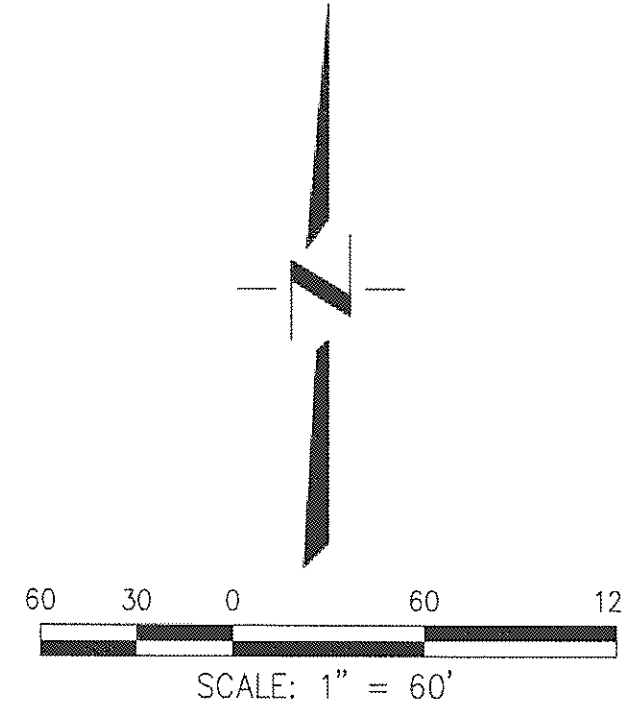

**SHEET INDEX:**

TENTATIVE MAP:	
TITLE SHEET	TM-1
PROPOSED SUBDIVISION LAYOUT	TM-2
EXISTING CONDITIONS	TM-3
PUD SCHEMATIC PLAN	PUD-1
REZONE EXHIBIT	R-1
GENERAL PLAN AMENDMENT	GP-1
PRELIMINARY GRADING AND UTILITY EXHIBIT	GU-1
COLOR PHOTOGRAPHS EXHIBIT	P-1

**TENTATIVE SUBDIVISION MAP FOR SUTTER MEMORIAL SITE PROPOSED SUBDIVISION LAYOUT**  
 SACRAMENTO CALIFORNIA

DESIGNED BY: DF  
 DRAWN BY: LE  
 CHECKED BY: DF  
 SCALE: AS SHOWN

S W A  
 Stonebridge Properties, LLC  
 2840 Spafford Street, Suite 200  
 Sacramento, CA 95818  
 (916) 455-2026

CECWEST.COM  
 Project Planning & Civil Engineering & Landscape Architecture  
 Sacramento Office  
 2120 20th Street, Suite Three  
 Sacramento, CA 95818  
 (916) 455-2026

CUNNINGHAM ENGINEERING

SHEET  
**TM-2**  
 OF  
**3**

DATE: 07/27/12  
 JOB NO: 1186.03

**SAHM**

**PROJECT REPORT**



## *General Model Information*

Project Name: Sutter  
Site Name:  
Site Address:  
City:  
Report Date: 4/8/2014  
Gage: RANCHO C  
Data Start: 1961/10/01  
Data End: 2004/09/30  
Timestep: Hourly  
Precip Scale: 0.94  
Version: 2013/12/06

## *POC Thresholds*

---

Low Flow Threshold for POC1:	25 Percent of the 2 Year
High Flow Threshold for POC1:	10 Year

---

## Landuse Basin Data

### Pre-Project Land Use

#### Pre Development

Bypass: No

GroundWater: No

Pervious Land Use Acres  
C,Grass,Mod (1-2%) 20

Pervious Total 20

Impervious Land Use Acres

Impervious Total 0

Basin Total 20

Element Flows To:  
Surface

Interflow

Groundwater

## Mitigated Land Use

### Bypass Open Space

Bypass: Yes

GroundWater: No

Pervious Land Use Acres  
C,Grass,Mod (1-2%) 6

Pervious Total 6

Impervious Land Use Acres

Impervious Total 0

Basin Total 6

Element Flows To:  
Surface

Interflow

Groundwater

## Rooftops and Sidewalks

Bypass: No  
Impervious Land Use Acres  
Imperv,Mod (1-2%) LAT 3.22  
Element Flows To:  
Outlet 1 Outlet 2  
Pervious Disconnection Landscaping

## Pervious Disconnection Landscaping

Bypass: No

GroundWater: No

Pervious Land Use Acres  
C,Grass,Mod (1-2%) 3.3

Element Flows To:

Surface	Interflow	Groundwater
Surface ention Areas	Surface ention Areas	

## Streets Imp and Trees

Bypass: No

GroundWater: No

Pervious Land Use Acres  
C,Trees,Mod (1-2%) 0.7

Pervious Total 0.7

Impervious Land Use Acres  
Imperv,Mod (1-2%) 6.78

Impervious Total 6.78

Basin Total 7.48

Element Flows To:

Surface	Interflow	Groundwater
Surface ention Areas	Surface ention Areas	

*Routing Elements*  
*Pre-Project Routing*

## Mitigated Routing

### All Bioretention Areas

Bottom Length:	209.40 ft.
Bottom Width:	209.40 ft.
Material thickness of first layer:	0.5
Material type for first layer:	Loam
Material thickness of second layer:	1.5
Material type for second layer:	Sand
Material thickness of third layer:	0.75
Material type for third layer:	GRAVEL
Infiltration On	
Infiltration rate:	0.17
Infiltration safety factor:	1
Total Volume Infiltrated (ac-ft):	471.189
Total Volume Through Riser (ac-ft):	35.237
Total Volume Through Facility (ac-ft):	506.426
Percent Infiltrated:	93.04
Underdrain used	
Underdrain Diameter (ft):	0.25
Orifice Diameter (in):	1
Offset (in):	6
Flow Through Underdrain (ac-ft):	0.936
Total Outflow (ac-ft):	506.426
Percent Through Underdrain:	0.18
Discharge Structure	
Riser Height:	1 ft.
Riser Diameter:	10 in.
Notch Type:	Rectangular
Notch Width:	0.000 ft.
Notch Height:	0.000 ft.
Element Flows To:	
Outlet 1	Outlet 2

Landscape Swale Hydraulic Table

Stage(ft)	Area(ac)	Volume(ac-ft)	Discharge(cfs)	Infilt(cfs)
0.0000	1.0066	0.0000	0.0000	0.0000
0.0522	1.0066	0.0235	0.0000	0.0000
0.1044	1.0066	0.0470	0.0000	0.0000
0.1566	1.0066	0.0705	0.0000	0.0000
0.2088	1.0066	0.0939	0.0000	0.0000
0.2610	1.0066	0.1174	0.0000	0.0000
0.3132	1.0066	0.1409	0.0000	0.0000
0.3654	1.0066	0.1644	0.0000	0.0000
0.4176	1.0066	0.1879	0.0000	0.0000
0.4698	1.0066	0.2114	0.0000	0.0000
0.5220	1.0066	0.2324	0.0000	0.0000
0.5742	1.0066	0.2534	0.0000	0.0000
0.6264	1.0066	0.2744	0.0000	0.0000
0.6786	1.0066	0.2955	0.0000	0.0000
0.7308	1.0066	0.3165	0.0000	0.0000
0.7830	1.0066	0.3375	0.0000	0.0000
0.8352	1.0066	0.3585	0.0000	0.0000
0.8874	1.0066	0.3795	0.0000	0.0000
0.9396	1.0066	0.4005	0.0000	0.0000



0.9918	1.0066	0.4216	0.0000	0.0000
1.0440	1.0066	0.4426	0.0748	0.0000
1.0962	1.0066	0.4636	0.2420	0.0000
1.1484	1.0066	0.4846	0.4637	0.0000
1.2005	1.0066	0.5056	0.7289	0.0000
1.2527	1.0066	0.5266	1.0312	0.0000
1.3049	1.0066	0.5477	1.3667	0.0000
1.3571	1.0066	0.5687	1.7322	0.0000
1.4093	1.0066	0.5897	2.1255	0.0000
1.4615	1.0066	0.6107	2.5447	0.0000
1.5137	1.0066	0.6317	2.9884	0.0000
1.5659	1.0066	0.6527	3.4553	0.0000
1.6181	1.0066	0.6738	3.9442	0.0000
1.6703	1.0066	0.6948	4.4542	0.0000
1.7225	1.0066	0.7158	4.9844	0.0000
1.7747	1.0066	0.7368	5.5342	0.0000
1.8269	1.0066	0.7578	6.1028	0.0000
1.8791	1.0066	0.7788	6.6897	0.0000
1.9313	1.0066	0.7999	7.2942	0.0000
1.9835	1.0066	0.8209	7.9160	0.0000
2.0357	1.0066	0.8427	8.5545	0.0000
2.0879	1.0066	0.8645	9.2092	0.0000
2.1401	1.0066	0.8863	9.8799	0.0000
2.1923	1.0066	0.9081	10.566	0.0000
2.2445	1.0066	0.9299	11.268	0.0000
2.2967	1.0066	0.9517	11.984	0.0000
2.3489	1.0066	0.9735	12.715	0.0000
2.4011	1.0066	0.9953	13.460	0.0000
2.4533	1.0066	1.0171	14.219	0.0000
2.5055	1.0066	1.0389	14.992	0.0000
2.5577	1.0066	1.0607	15.778	0.0019
2.6099	1.0066	1.0826	16.578	0.0045
2.6621	1.0066	1.1044	17.391	0.0070
2.7143	1.0066	1.1262	18.216	0.0091
2.7500	1.0066	1.1411	19.054	0.0393

Landscape Swale Hydraulic Table

Stage(ft)	Area(ac)	Volume(ac-ft)	Discharge(cfs)	To Amended(cfs)	Infilt(cfs)
2.7500	1.0066	1.1411	0.0000	0.5826	0.0000
2.8022	1.0066	1.1936	0.0000	0.5826	0.0000
2.8544	1.0066	1.2462	0.0000	0.6376	0.0000
2.9066	1.0066	1.2987	0.0000	0.6927	0.0000
2.9588	1.0066	1.3513	0.0000	0.7478	0.0000
3.0110	1.0066	1.4038	0.0000	0.8028	0.0000
3.0632	1.0066	1.4563	0.0000	0.8579	0.0000
3.1154	1.0066	1.5089	0.0000	0.9130	0.0000
3.1676	1.0066	1.5614	0.0000	0.9680	0.0000
3.2198	1.0066	1.6140	0.0000	1.0231	0.0000
3.2720	1.0066	1.6665	0.0000	1.0782	0.0000
3.3242	1.0066	1.7191	0.0000	1.1332	0.0000
3.3764	1.0066	1.7716	0.0000	1.1883	0.0000
3.4286	1.0066	1.8241	0.0000	1.2434	0.0000
3.4808	1.0066	1.8767	0.0000	1.2984	0.0000
3.5330	1.0066	1.9292	0.0000	1.3535	0.0000
3.5852	1.0066	1.9818	0.0000	1.4086	0.0000
3.6374	1.0066	2.0343	0.0000	1.4636	0.0000
3.6896	1.0066	2.0869	0.0000	1.5187	0.0000
3.7418	1.0066	2.1394	0.0000	1.5738	0.0000

3.7940	1.0066	2.1919	0.0748	1.6288	0.0000
3.8462	1.0066	2.2445	0.2420	1.6839	0.0000
3.8984	1.0066	2.2970	0.4637	1.7390	0.0000
3.9505	1.0066	2.3496	0.7289	1.7940	0.0000
4.0027	1.0066	2.4021	1.0312	1.8491	0.0000
4.0549	1.0066	2.4547	1.3667	1.9042	0.0000
4.1071	1.0066	2.5072	1.7322	1.9592	0.0000
4.1593	1.0066	2.5598	2.1255	2.0143	0.0000
4.2115	1.0066	2.6123	2.5447	2.0694	0.0000
4.2637	1.0066	2.6648	2.9884	2.1244	0.0000
4.3159	1.0066	2.7174	3.4553	2.1795	0.0000
4.3681	1.0066	2.7699	3.9442	2.2346	0.0000
4.4203	1.0066	2.8225	4.4542	2.2896	0.0000
4.4725	1.0066	2.8750	4.9844	2.3447	0.0000
4.5247	1.0066	2.9276	5.5342	2.3998	0.0000
4.5769	1.0066	2.9801	6.1028	2.4548	0.0000
4.6291	1.0066	3.0326	6.6897	2.5099	0.0000
4.6813	1.0066	3.0852	7.2942	2.5650	0.0000
4.7335	1.0066	3.1377	7.9160	2.6200	0.0000
4.7500	1.0066	3.1543	8.5545	2.6374	0.0000

## Surface ention Areas

Element Flows To:

Outlet 1

Outlet 2

All Bioretention Areas

# Analysis Results

## POC 1

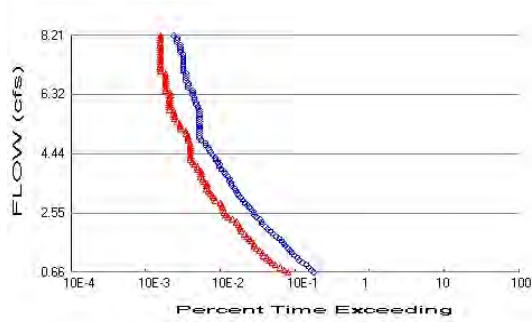

+ Pre-Project

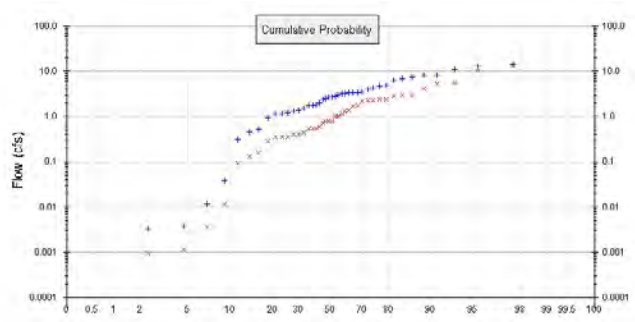

x Mitigated

### Pre-Project Landuse Totals for POC #1

Total Pervious Area: 20  
Total Impervious Area: 0

### Mitigated Landuse Totals for POC #1

Total Pervious Area: 10  
Total Impervious Area: 10

Flow Frequency Method: Log Pearson Type III 17B

### Flow Frequency Return Periods for Pre-Project. POC #1

Return Period	Flow(cfs)
2 year	2.65473
5 year	5.161155
10 year	8.210895
25 year	13.451809

### Flow Frequency Return Periods for Mitigated. POC #1

Return Period	Flow(cfs)
2 year	0.798734
5 year	2.455523
10 year	4.853076
25 year	11.014309

## Annual Peaks

### Annual Peaks for Pre-Project and Mitigated. POC #1

Year	Pre-Project	Mitigated
1962	2.989	1.293
1963	1.164	0.349
1964	0.038	0.011
1965	2.658	0.799
1966	0.012	0.004
1967	3.275	2.333
1968	0.525	0.158
1969	3.240	2.375
1970	2.492	0.804
1971	3.509	2.373
1972	0.004	0.001
1973	7.615	2.285
1974	1.996	0.599
1975	2.410	0.723

1976	0.003	0.001
1977	0.002	0.001
1978	3.336	1.002
1979	1.350	0.405
1980	4.647	1.394
1981	0.305	0.093
1982	6.241	2.914
1983	8.184	5.429
1984	2.797	1.731
1985	1.474	0.442
1986	13.356	10.637
1987	0.446	0.134
1988	1.829	0.549
1989	3.939	1.182
1990	2.655	0.796
1991	1.783	0.537
1992	4.403	1.772
1993	3.330	2.219
1994	1.342	0.403
1995	14.059	13.403
1996	8.233	2.819
1997	10.828	4.162
1998	7.056	5.479
1999	1.785	0.537
2000	4.921	2.967
2001	1.189	0.357
2002	1.151	0.345
2003	0.938	0.282
2004	3.343	1.003

### Ranked Annual Peaks

Ranked Annual Peaks for Pre-Project and Mitigated. POC #1

Rank	Pre-Project	Mitigated
1	14.0586	13.4033
2	13.3560	10.6371
3	10.8277	5.4785
4	8.2335	5.4293
5	8.1838	4.1616
6	7.6153	2.9665
7	7.0565	2.9141
8	6.2415	2.8193
9	4.9211	2.3747
10	4.6470	2.3732
11	4.4030	2.3330
12	3.9388	2.2846
13	3.5095	2.2185
14	3.3429	1.7716
15	3.3358	1.7308
16	3.3303	1.3941
17	3.2751	1.2930
18	3.2398	1.1817
19	2.9893	1.0029
20	2.7965	1.0022
21	2.6579	0.8041
22	2.6547	0.7987
23	2.4919	0.7964
24	2.4104	0.7231
25	1.9956	0.5987

26	1.8293	0.5488
27	1.7851	0.5369
28	1.7829	0.5366
29	1.4743	0.4423
30	1.3496	0.4049
31	1.3422	0.4027
32	1.1885	0.3566
33	1.1636	0.3491
34	1.1509	0.3453
35	0.9385	0.2815
36	0.5255	0.1576
37	0.4459	0.1338
38	0.3049	0.0929
39	0.0382	0.0115
40	0.0118	0.0036
41	0.0037	0.0011
42	0.0032	0.0010
43	0.0024	0.0007

## Duration Flows

The Facility PASSED

Flow(cfs)	Predev	Mit	Percentage	Pass/Fail
0.6637	681	307	45	Pass
0.7399	623	274	43	Pass
0.8162	584	241	41	Pass
0.8924	536	207	38	Pass
0.9686	482	187	38	Pass
1.0449	433	172	39	Pass
1.1211	409	159	38	Pass
1.1973	373	145	38	Pass
1.2736	345	138	40	Pass
1.3498	330	127	38	Pass
1.4260	304	115	37	Pass
1.5023	285	109	38	Pass
1.5785	270	107	39	Pass
1.6547	252	98	38	Pass
1.7310	234	93	39	Pass
1.8072	211	85	40	Pass
1.8834	195	80	41	Pass
1.9597	179	72	40	Pass
2.0359	164	71	43	Pass
2.1121	153	69	45	Pass
2.1884	138	66	47	Pass
2.2646	135	63	46	Pass
2.3408	127	55	43	Pass
2.4171	117	48	41	Pass
2.4933	109	45	41	Pass
2.5695	106	43	40	Pass
2.6458	101	42	41	Pass
2.7220	93	41	44	Pass
2.7982	87	40	45	Pass
2.8745	81	38	46	Pass
2.9507	76	33	43	Pass
3.0270	71	31	43	Pass
3.1032	67	30	44	Pass
3.1794	65	28	43	Pass
3.2557	61	26	42	Pass
3.3319	59	25	42	Pass
3.4081	54	25	46	Pass
3.4844	53	25	47	Pass
3.5606	51	23	45	Pass
3.6368	51	22	43	Pass
3.7131	48	21	43	Pass
3.7893	44	21	47	Pass
3.8655	43	21	48	Pass
3.9418	39	19	48	Pass
4.0180	37	19	51	Pass
4.0942	37	17	45	Pass
4.1705	35	16	45	Pass
4.2467	33	15	45	Pass
4.3229	32	15	46	Pass
4.3992	30	15	50	Pass
4.4754	28	15	53	Pass
4.5516	27	15	55	Pass
4.6279	26	15	57	Pass

4.7041	24	15	62	Pass
4.7803	24	15	62	Pass
4.8566	21	14	66	Pass
4.9328	20	14	70	Pass
5.0090	20	14	70	Pass
5.0853	20	13	65	Pass
5.1615	20	13	65	Pass
5.2378	20	11	55	Pass
5.3140	20	11	55	Pass
5.3902	20	11	55	Pass
5.4665	20	10	50	Pass
5.5427	20	9	45	Pass
5.6189	20	9	45	Pass
5.6952	20	9	45	Pass
5.7714	20	9	45	Pass
5.8476	20	8	40	Pass
5.9239	19	8	42	Pass
6.0001	18	8	44	Pass
6.0763	18	8	44	Pass
6.1526	17	8	47	Pass
6.2288	17	8	47	Pass
6.3050	16	8	50	Pass
6.3813	16	8	50	Pass
6.4575	16	7	43	Pass
6.5337	14	7	50	Pass
6.6100	14	7	50	Pass
6.6862	14	7	50	Pass
6.7624	13	7	53	Pass
6.8387	13	7	53	Pass
6.9149	13	7	53	Pass
6.9911	13	7	53	Pass
7.0674	12	6	50	Pass
7.1436	12	6	50	Pass
7.2198	12	6	50	Pass
7.2961	12	6	50	Pass
7.3723	12	6	50	Pass
7.4486	12	6	50	Pass
7.5248	12	6	50	Pass
7.6010	12	6	50	Pass
7.6773	11	6	54	Pass
7.7535	11	6	54	Pass
7.8297	11	6	54	Pass
7.9060	11	6	54	Pass
7.9822	10	6	60	Pass
8.0584	10	6	60	Pass
8.1347	10	6	60	Pass
8.2109	9	6	66	Pass



Water Quality  
Drawdown Time Results

## *Model Default Modifications*

Total of 0 changes have been made.

### *PERLND Changes*

No PERLND changes have been made.

### *IMPLND Changes*

No IMPLND changes have been made.

*Appendix*  
*Pre-Project Schematic*



Mitigated Schematic

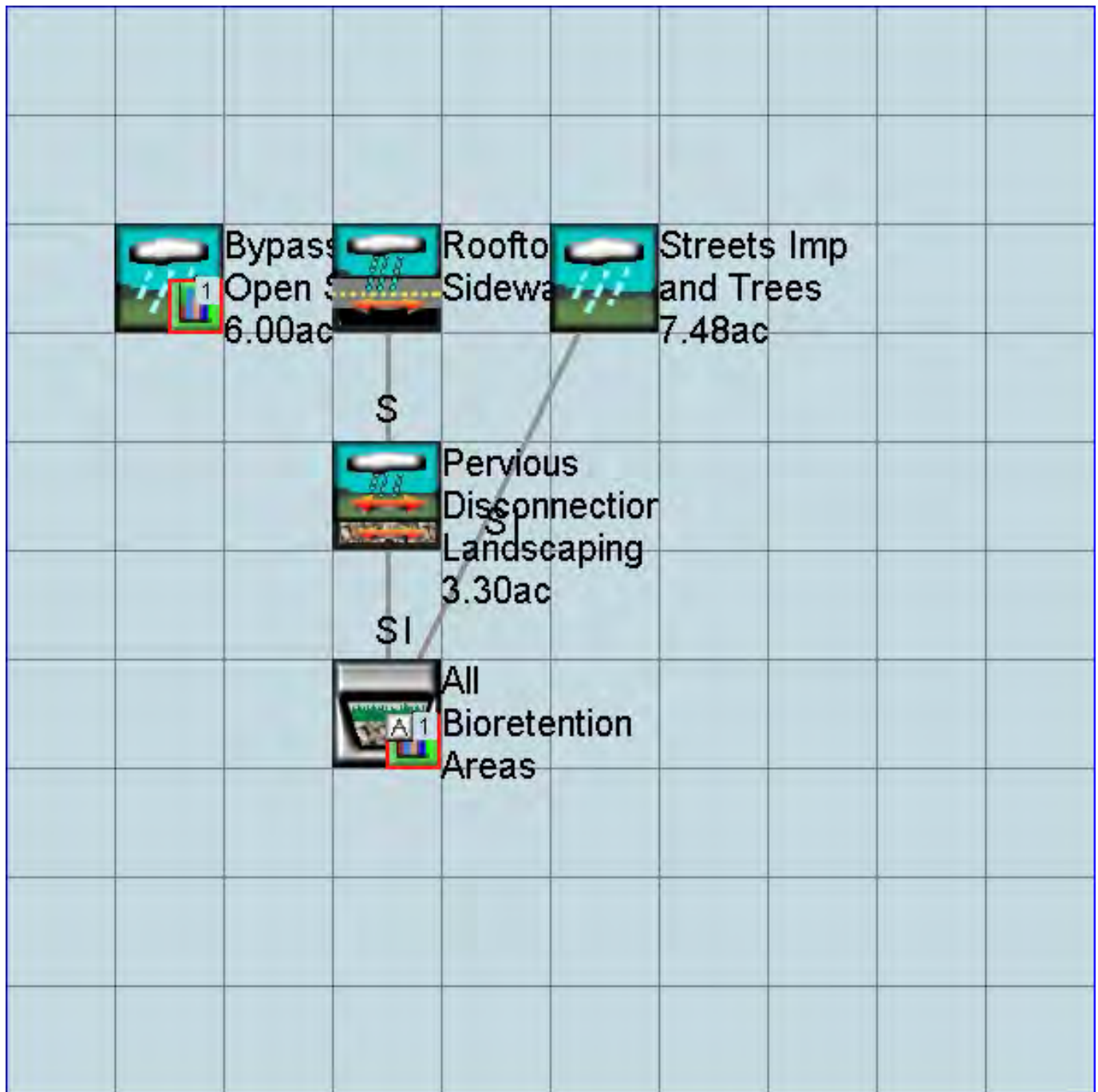

# Pre-Project UCI File

RUN

GLOBAL

```
WWM4 model simulation
START      1961 10 01      END      2004 09 30
RUN INTERP OUTPUT LEVEL   3      0
RESUME     0 RUN          1
UNIT SYSTEM 1
```

END GLOBAL

FILES

```
<File> <Un#> <-----File Name----->***
<-ID->                                     ***
WDM      26      Sutter.wdm
MESSU    25      PreSutter.MES
          27      PreSutter.L61
          28      PreSutter.L62
          30      POCsutter1.dat
```

END FILES

OPN SEQUENCE

```
INGRP          INDELT 00:60
  PERLND        34
  COPY          501
  DISPLY        1
```

END INGRP

END OPN SEQUENCE

DISPLY

DISPLY-INFO1

```
# - #<-----Title----->***TRAN PIVL DIG1 FIL1  PYR DIG2 FIL2 YRND
1      Pre Development          MAX          1  2  30  9
```

END DISPLY-INFO1

END DISPLY

COPY

TIMESERIES

```
# - # NPT NMN ***
1      1  1
501    1  1
```

END TIMESERIES

END COPY

GENER

OPCODE

```
# # OPCODE ***
```

END OPCODE

PARAM

```
# # K ***
```

END PARAM

END GENER

PERLND

GEN-INFO

```
<PLS ><-----Name----->NBLKS  Unit-systems  Printer ***
# - #          User  t-series  Engl Metr ***
          in  out          ***
34      C,Grass,Mod (1-2%)  1  1  1  1  27  0
```

END GEN-INFO

\*\*\* Section PWATER\*\*\*

ACTIVITY

```
<PLS > ***** Active Sections *****
# - # ATMP SNOW PWAT  SED  PST  PWG  PQAL MSTL PEST NITR PHOS TRAC ***
34      0  0  1  0  0  0  0  0  0  0  0  0  0
```

END ACTIVITY

PRINT-INFO

```
<PLS > ***** Print-flags ***** PIVL  PYR
# - # ATMP SNOW PWAT  SED  PST  PWG  PQAL MSTL PEST NITR PHOS TRAC *****
34      0  0  4  0  0  0  0  0  0  0  0  0  0  1  9
```

END PRINT-INFO

```

PWAT-PARM1
<PLS > PWATER variable monthly parameter value flags ***
# - # CSNO RTOP UZFG VCS VUZ VNN VIFW VIRG VLE INFC HWT ***
34 0 0 0 1 0 0 0 0 0 1 0 0
END PWAT-PARM1

PWAT-PARM2
<PLS > PWATER input info: Part 2 ***
# - # ***FOREST LZSN INFILT LSUR SLSUR KVARY AGWRC
34 0 4.45 0.043 400 0.02 3 0.92
END PWAT-PARM2

PWAT-PARM3
<PLS > PWATER input info: Part 3 ***
# - # ***PETMAX PETMIN INFEXP INFILD DEEPFR BASETP AGWETP
34 40 35 2 2 0 0 0.05
END PWAT-PARM3

PWAT-PARM4
<PLS > PWATER input info: Part 4 ***
# - # CEPSC UZSN NSUR INTFW IRC LZETP ***
34 0 0.28 0.25 0.65 0.48 0
END PWAT-PARM4

MON-LZETPARM
<PLS > PWATER input info: Part 3 ***
# - # JAN FEB MAR APR MAY JUN JUL AUG SEP OCT NOV DEC ***
34 0.4 0.4 0.4 0.45 0.5 0.55 0.55 0.55 0.55 0.55 0.45 0.4
END MON-LZETPARM

MON-INTERCEP
<PLS > PWATER input info: Part 3 ***
# - # JAN FEB MAR APR MAY JUN JUL AUG SEP OCT NOV DEC ***
34 0.12 0.12 0.12 0.11 0.1 0.1 0.1 0.1 0.1 0.1 0.11 0.12
END MON-INTERCEP

PWAT-STATE1
<PLS > *** Initial conditions at start of simulation
ran from 1990 to end of 1992 (pat 1-11-95) RUN 21 ***
# - # *** CEPS SURS UZS IFWS LZS AGWS GWVS
34 0 0 0.15 0 4 0.05 0
END PWAT-STATE1

END PERLND

IMPLND
GEN-INFO
<PLS ><-----Name-----> Unit-systems Printer ***
# - # User t-series Engl Metr ***
in out ***

END GEN-INFO
*** Section IWATER***

ACTIVITY
<PLS > ***** Active Sections *****
# - # ATMP SNOW IWAT SLD IWG IQAL ***
END ACTIVITY

PRINT-INFO
<ILS > ***** Print-flags ***** PIVL PYR
# - # ATMP SNOW IWAT SLD IWG IQAL *****
END PRINT-INFO

IWAT-PARM1
<PLS > IWATER variable monthly parameter value flags ***
# - # CSNO RTOP VRS VNN RTLI ***
END IWAT-PARM1

IWAT-PARM2
<PLS > IWATER input info: Part 2 ***
# - # *** LSUR SLSUR NSUR RETSC
END IWAT-PARM2

```



SPEC-ACTIONS  
 END SPEC-ACTIONS  
 FTABLES  
 END FTABLES

EXT SOURCES

<-Volume->	<Member>	SsysSgap	<--Mult-->	Tran	<-Target vols>	<-Grp>	<-Member->	***	
<Name>	#	<Name>	#	tem strg	<-factor->	strg	<Name>	# #	***
WDM	2	PREC		ENGL	0.944		PERLND	1 999	EXTNL PREC
WDM	2	PREC		ENGL	0.944		IMPLND	1 999	EXTNL PREC
WDM	1	EVAP		ENGL	1		PERLND	1 999	EXTNL PETINP
WDM	1	EVAP		ENGL	1		IMPLND	1 999	EXTNL PETINP

END EXT SOURCES

EXT TARGETS

<-Volume->	<-Grp>	<-Member->	<--Mult-->	Tran	<-Volume->	<Member>	Tsys	Tgap	Amd	***
<Name>	#	<Name>	#	#<-factor->	strg	<Name>	#	<Name>	tem strg	strg***
COPY	501	OUTPUT	MEAN	1 1	12.1	WDM	501	FLOW	ENGL	REPL

END EXT TARGETS

MASS-LINK

<Volume>	<-Grp>	<-Member->	<--Mult-->	<Target>	<-Grp>	<-Member->	***
<Name>	#	<Name>	#	<-factor->	<Name>	#	#***
MASS-LINK			12				
PERLND	PWATER	SURO		0.083333	COPY	INPUT	MEAN
END MASS-LINK			12				
MASS-LINK			13				
PERLND	PWATER	IFWO		0.083333	COPY	INPUT	MEAN
END MASS-LINK			13				

END MASS-LINK

END RUN



# Mitigated UCI File

RUN

GLOBAL

```
WVHM4 model simulation
START      1961 10 01      END      2004 09 30
RUN INTERP OUTPUT LEVEL   3      0
RESUME     0 RUN         1
UNIT SYSTEM 1
```

END GLOBAL

FILES

```
<File> <Un#> <-----File Name----->***
<-ID->                                     ***
WDM      26      Sutter.wdm
MESSU    25      MitSutter.MES
          27      MitSutter.L61
          28      MitSutter.L62
          30      POCsutter1.dat
```

END FILES

OPN SEQUENCE

```
INGRP          INDELT 00:60
  PERLND        34
  IMPLND         6
  PERLND        46
  IMPLND         2
  PERLND        66
  GENER         2
  RCHRES         1
  RCHRES         2
  COPY           1
  COPY          501
  COPY          601
  DISPLY         1
```

END INGRP

END OPN SEQUENCE

DISPLY

DISPLY-INFO1

```
# - #<-----Title----->***TRAN PIVL DIG1 FIL1  PYR DIG2 FIL2 YRND
1      Surface ention Areas          MAX          1    2    30    9
```

END DISPLY-INFO1

END DISPLY

COPY

TIMESERIES

```
# - # NPT NMN ***
1      1      1
501    1      1
601    1      1
```

END TIMESERIES

END COPY

GENER

OPCODE

```
#      # OPCD ***
2      24
```

END OPCODE

PARM

```
#      #          K ***
2      0.
```

END PARM

END GENER

PERLND

GEN-INFO

```
<PLS ><-----Name----->NBLKS  Unit-systems  Printer ***
# - #          User  t-series  Engl Metr ***
          in  out          ***
34      C,Grass,Mod (1-2%)  1    1    1    1    27    0
46      C,Trees,Mod (1-2%)  1    1    1    1    27    0
66      C,Grass,Mod (1-2%)  1    1    1    1    27    0
```

END GEN-INFO

\*\*\* Section PWATER\*\*\*

ACTIVITY

```
<PLS > ***** Active Sections *****
# - # ATMP SNOW PWAT SED PST PWG PQAL MSTL PEST NITR PHOS TRAC ***
34      0  0  1  0  0  0  0  0  0  0  0  0  0
46      0  0  1  0  0  0  0  0  0  0  0  0  0
66      0  0  1  0  0  0  0  0  0  0  0  0  0
END ACTIVITY
```

PRINT-INFO

```
<PLS > ***** Print-flags ***** PIVL  PYR
# - # ATMP SNOW PWAT SED PST PWG PQAL MSTL PEST NITR PHOS TRAC *****
34      0  0  4  0  0  0  0  0  0  0  0  0  1  9
46      0  0  4  0  0  0  0  0  0  0  0  0  1  9
66      0  0  4  0  0  0  0  0  0  0  0  0  1  9
END PRINT-INFO
```

PWAT-PARM1

```
<PLS > PWATER variable monthly parameter value flags ***
# - # CSNO RTOP UZFG VCS VUZ VNM VIFW VIRC VLE INFC HWT ***
34      0  0  0  1  0  0  0  0  1  0  0
46      0  0  0  1  0  0  0  0  1  0  0
66      0  0  0  1  0  0  0  0  1  0  0
END PWAT-PARM1
```

PWAT-PARM2

```
<PLS > PWATER input info: Part 2 ***
# - # ***FOREST LZSN INFILT LSUR SLSUR KVARY AGWRC
34      0  4.45 0.043 400 0.02 3 0.92
46      0  4.9 0.05 400 0.02 3 0.92
66      0  4.45 0.043 400 0.02 3 0.92
END PWAT-PARM2
```

PWAT-PARM3

```
<PLS > PWATER input info: Part 3 ***
# - # ***PETMAX PETMIN INFEXP INFILD DEEPFR BASETP AGWETP
34      40 35 2 2 0 0 0.05
46      40 35 2 2 0 0 0.05
66      40 35 2 2 0 0 0.05
END PWAT-PARM3
```

PWAT-PARM4

```
<PLS > PWATER input info: Part 4 ***
# - # CEPSC UZSN NSUR INTFW IRC LZETP ***
34      0 0.28 0.25 0.65 0.48 0
46      0 0.33 0.35 0.78 0.58 0
66      0 0.28 0.25 0.65 0.48 0
END PWAT-PARM4
```

MON-LZETPARAM

```
<PLS > PWATER input info: Part 3 ***
# - # JAN FEB MAR APR MAY JUN JUL AUG SEP OCT NOV DEC ***
34      0.4 0.4 0.4 0.45 0.5 0.55 0.55 0.55 0.55 0.55 0.45 0.4
46      0.6 0.6 0.6 0.7 0.75 0.75 0.75 0.75 0.75 0.75 0.65 0.6
66      0.4 0.4 0.4 0.45 0.5 0.55 0.55 0.55 0.55 0.55 0.45 0.4
END MON-LZETPARAM
```

MON-INTERCEP

```
<PLS > PWATER input info: Part 3 ***
# - # JAN FEB MAR APR MAY JUN JUL AUG SEP OCT NOV DEC ***
34      0.12 0.12 0.12 0.11 0.1 0.1 0.1 0.1 0.1 0.1 0.11 0.12
46      0.15 0.15 0.15 0.2 0.2 0.2 0.2 0.2 0.2 0.2 0.2 0.18
66      0.12 0.12 0.12 0.11 0.1 0.1 0.1 0.1 0.1 0.1 0.11 0.12
END MON-INTERCEP
```

PWAT-STATE1

```
<PLS > *** Initial conditions at start of simulation
ran from 1990 to end of 1992 (pat 1-11-95) RUN 21 ***
# - # *** CEPS SURS UZS IFWS LZS AGWS GWVS
34      0 0 0.15 0 4 0.05 0
46      0 0 0.15 0 4 0.05 0
66      0 0 0.15 0 4 0.05 0
```

END PWAT-STATE1

END PERLND

IMPLND

GEN-INFO

<PLS ><-----Name----->		Unit-systems		Printer		***
#	#	User	t-series	Engl	Metr	***
		in out				***
6	Imperv,Mod (1-2%) LAT	1	1	1	27	0
2	Imperv,Mod (1-2%)	1	1	1	27	0

END GEN-INFO

\*\*\* Section IWATER\*\*\*

ACTIVITY

<PLS >		***** Active Sections *****						***
#	#	ATMP	SNOW	IWAT	SLD	IWG	IQAL	***
6		0	0	1	0	0	0	
2		0	0	1	0	0	0	

END ACTIVITY

PRINT-INFO

<ILS >		***** Print-flags *****						PIVL	PYR	***
#	#	ATMP	SNOW	IWAT	SLD	IWG	IQAL			***
6		0	0	4	0	0	0	1	9	
2		0	0	4	0	0	0	1	9	

END PRINT-INFO

IWAT-PARM1

<PLS >		IWATER variable monthly parameter value flags						***
#	#	CSNO	RTOP	VRS	VNN	RTL	LI	***
6		0	0	0	0	0	0	
2		0	0	0	0	0	0	

END IWAT-PARM1

IWAT-PARM2

<PLS >		IWATER input info: Part 2					***
#	#	***	LSUR	SLSUR	NSUR	RETSC	***
6			100	0.02	0.05	0.1	
2			100	0.02	0.05	0.1	

END IWAT-PARM2

IWAT-PARM3

<PLS >		IWATER input info: Part 3			***
#	#	***	PETMAX	PETMIN	***
6			0	0	
2			0	0	

END IWAT-PARM3

IWAT-STATE1

<PLS >		*** Initial conditions at start of simulation		
#	#	***	RETS	SURS
6			0	0
2			0	0

END IWAT-STATE1

END IMPLND

SCHEMATIC

<-Source->	<--Area-->	<-Target->	MBLK	***
<Name>	#	<-factor->	<Name>	#
Tbl#				
Rooftops and Sidewalks***				
IMPLND	6	0.9758	PERLND	66
Pervious Disconnection Landscaping***				
PERLND	66	3.3	RCHRES	1
PERLND	66	3.3	RCHRES	1
Streets Imp and Trees***				
PERLND	46	0.7	RCHRES	1
PERLND	46	0.7	RCHRES	1
IMPLND	2	6.78	RCHRES	1

Bypass Open Space\*\*\*

PERLND	34	6	COPY	501	12
PERLND	34	6	COPY	601	12
PERLND	34	6	COPY	501	13
PERLND	34	6	COPY	601	13

\*\*\*\*\*Routing\*\*\*\*\*

PERLND	66	3.3	COPY	1	12
PERLND	66	3.3	COPY	1	13
PERLND	46	0.7	COPY	1	12
IMPLND	2	6.78	COPY	1	15
PERLND	46	0.7	COPY	1	13
RCHRES	1	1	COPY	1	18
RCHRES	1		RCHRES	2	8
RCHRES	2	1	COPY	501	17
RCHRES	1	1	COPY	501	17

END SCHEMATIC

NETWORK

```

<-Volume-> <-Grp> <-Member-><--Mult-->Tran <-Target vols> <-Grp> <-Member-> ***
<Name> # <Name> # #<-factor->strg <Name> # # <Name> # # ***
COPY 501 OUTPUT MEAN 1 1 12.1 DISPLY 1 INPUT TIMSER 1
GENER 2 OUTPUT TIMSER .0002778 RCHRES 1 EXTNL OUTDGT 1

```

```

<-Volume-> <-Grp> <-Member-><--Mult-->Tran <-Target vols> <-Grp> <-Member-> ***
<Name> # <Name> # #<-factor->strg <Name> # # <Name> # # ***
END NETWORK

```

RCHRES

GEN-INFO

RCHRES	Name	Nexits	Unit	Systems	Printer	
# - #	<-----><---->	User	T-series	Engl	Metr	LKFG
			in	out		
1	Surface ention A-009	3	1	1	1	28 0 1
2	All Bioretention-008	2	1	1	1	28 0 1

END GEN-INFO

\*\*\* Section RCHRES\*\*\*

ACTIVITY

```

<PLS > ***** Active Sections *****
# - # HYFG ADFG CNFG HTFG SDFG GQFG OXFG NUFG PKFG PHFG ***
1 1 0 0 0 0 0 0 0 0 0 0
2 1 0 0 0 0 0 0 0 0 0 0

```

END ACTIVITY

PRINT-INFO

```

<PLS > ***** Print-flags ***** PIVL PYR *****
# - # HYDR ADCA CONS HEAT SED GQL OXRX NUTR PLNK PHCB PIVL PYR *****
1 4 0 0 0 0 0 0 0 0 0 0 1 9
2 4 0 0 0 0 0 0 0 0 0 0 1 9

```

END PRINT-INFO

HYDR-PARM1

RCHRES	Flags for each HYDR Section	ODFVFG for each possible exit	ODGTFG for each possible exit	FUNCT for each possible exit
# - #	VC A1 A2 A3 FG FG FG FG	* * * * *	* * * * *	* * * * *
1	0 1 0 0	4 5 6 0 0	0 1 0 0 0	2 1 2 2 2
2	0 1 0 0	4 5 0 0 0	0 0 0 0 0	2 2 2 2 2

END HYDR-PARM1

HYDR-PARM2

# - #	FTABNO	LEN	DELTH	STCOR	KS	DB50
1	1	0.01	0.0	0.0	0.5	0.0
2	2	0.04	0.0	0.0	0.5	0.0

END HYDR-PARM2

HYDR-INIT

```

RCHRES Initial conditions for each HYDR section ***
# - # *** VOL Initial value of COLIND Initial value of OUTDGT
*** ac-ft for each possible exit for each possible exit
<-----><-----> <---><---><---><---><---> *** <---><---><---><---><--->
1 0 4.0 5.0 6.0 0.0 0.0 0.0 0.0 0.0 0.0
2 0 4.0 5.0 0.0 0.0 0.0 0.0 0.0 0.0 0.0
END HYDR-INIT
END RCHRES

```

SPEC-ACTIONS

```

*** User-Defined Variable Quantity Lines
***
***
*** kwd varnam optyp opn vari s1 s2 s3 tp multiply lc ls ac as agfn ***
<****> <-----> <-----> <--> <-----><--><--><--><--><-----> <--><--> <--> ***
UVQUAN vol2 RCHRES 2 VOL 4
UVQUAN v2m2 GLOBAL WORKSP 1 3
UVQUAN vpo2 GLOBAL WORKSP 2 3
UVQUAN v2d2 GENER 2 K 1 3
*** User-Defined Target Variable Names
***
***
*** kwd varnam ct vari s1 s2 s3 frac oper vari s1 s2 s3 frac oper
<****> <-----><--> <-----><--><--><--> <-----> <--> <-----><--><--><--> <-----> <-->
UVNAME v2m2 1 WORKSP 1 1.0 QUAN
UVNAME vpo2 1 WORKSP 2 1.0 QUAN
UVNAME v2d2 1 K 1 1.0 QUAN
*** opt foplop dcdts yr mo dy hr mn d t vnam s1 s2 s3 ac quantity tc ts rp
<****><--><--><--><--><--> <--> <--> <--> <--><--> <-----><--><--><--><--><-----> <--> <--><-->
GENER 2 v2m2 = 46602.
*** Compute remaining available pore space
GENER 2 vpo2 = v2m2
GENER 2 vpo2 -= vol2
*** Check to see if VPORA goes negative; if so set VPORA = 0.0
IF (vpo2 < 0.0) THEN
GENER 2 vpo2 = 0.0
END IF
*** Infiltration volume
GENER 2 v2d2 = vpo2
END SPEC-ACTIONS

```

FTABLES

```

FTABLE 2
54 5
Depth Area Volume Outflow1 Outflow2 Velocity Travel Time***
(ft) (acres) (acre-ft) (cfs) (cfs) (ft/sec) (Minutes)***
0.000000 1.006620 0.000000 0.000000 0.000000
0.052198 1.006620 0.023487 0.000000 0.000000
0.104396 1.006620 0.046974 0.000000 0.000000
0.156593 1.006620 0.070461 0.000000 0.000000
0.208791 1.006620 0.093947 0.000000 0.000000
0.260989 1.006620 0.117434 0.000000 0.003269
0.313187 1.006620 0.140921 0.000000 0.014306
0.365385 1.006620 0.164408 0.000000 0.019017
0.417582 1.006620 0.187895 0.000000 0.023854
0.469780 1.006620 0.211382 0.000000 0.035570
0.521978 1.006620 0.232399 0.000000 0.036548
0.574176 1.006620 0.253417 0.000000 0.052689
0.626374 1.006620 0.274434 0.000000 0.064870
0.678571 1.006620 0.295451 0.000000 0.084749
0.730769 1.006620 0.316469 0.000000 0.096400
0.782967 1.006620 0.337486 0.000000 0.124470
0.835165 1.006620 0.358503 0.000000 0.135901
0.887363 1.006620 0.379521 0.000000 0.167534
0.939560 1.006620 0.400538 0.000000 0.172551
0.991758 1.006620 0.421555 0.000000 0.172551
1.043956 1.006620 0.442573 0.000000 0.172551
1.096154 1.006620 0.463590 0.000000 0.172551
1.148352 1.006620 0.484607 0.000000 0.172551
1.200549 1.006620 0.505625 0.000000 0.172551
1.252747 1.006620 0.526642 0.000000 0.172551

```

1.304945	1.006620	0.547659	0.000000	0.172551
1.357143	1.006620	0.568677	0.000000	0.172551
1.409341	1.006620	0.589694	0.000000	0.172551
1.461538	1.006620	0.610711	0.000000	0.172551
1.513736	1.006620	0.631729	0.000000	0.172551
1.565934	1.006620	0.652746	0.000000	0.172551
1.618132	1.006620	0.673763	0.000000	0.172551
1.670330	1.006620	0.694781	0.000000	0.172551
1.722527	1.006620	0.715798	0.000000	0.172551
1.774725	1.006620	0.736815	0.000000	0.172551
1.826923	1.006620	0.757833	0.000000	0.172551
1.879121	1.006620	0.778850	0.000000	0.172551
1.931319	1.006620	0.799867	0.000000	0.172551
1.983516	1.006620	0.820885	0.000000	0.172551
2.035714	1.006620	0.842690	0.000000	0.172551
2.087912	1.006620	0.864496	0.000000	0.172551
2.140110	1.006620	0.886301	0.000000	0.172551
2.192308	1.006620	0.908107	0.000000	0.172551
2.244505	1.006620	0.929912	0.000000	0.172551
2.296703	1.006620	0.951718	0.000000	0.172551
2.348901	1.006620	0.973523	0.000000	0.172551
2.401099	1.006620	0.995329	0.000000	0.172551
2.453297	1.006620	1.017134	0.000000	0.172551
2.505495	1.006620	1.038940	0.000000	0.172551
2.557692	1.006620	1.060745	0.001874	0.172551
2.609890	1.006620	1.082550	0.004511	0.172551
2.662088	1.006620	1.104356	0.006957	0.172551
2.714286	1.006620	1.126161	0.009105	0.172551
2.750000	1.006620	2.396270	0.039321	0.172551

END FTABLE 2

FTABLE 1

40 6

Depth	Area	Volume	Outflow1	Outflow2	outflow 3	Velocity	Travel
Time***	(ft)	(acres)	(acre-ft)	(cfs)	(cfs)	(cfs)	(ft/sec)
(Minutes)***							
0.000000	1.006620	0.000000	0.000000	0.039321	0.000000		
0.052198	1.006620	0.052543	0.000000	0.582552	0.000000		
0.104396	1.006620	0.105087	0.000000	0.637619	0.000000		
0.156593	1.006620	0.157630	0.000000	0.692686	0.000000		
0.208791	1.006620	0.210173	0.000000	0.747754	0.000000		
0.260989	1.006620	0.262717	0.000000	0.802821	0.000000		
0.313187	1.006620	0.315260	0.000000	0.857888	0.000000		
0.365385	1.006620	0.367803	0.000000	0.912955	0.000000		
0.417582	1.006620	0.420347	0.000000	0.968022	0.000000		
0.469780	1.006620	0.472890	0.000000	1.023089	0.000000		
0.521978	1.006620	0.525433	0.000000	1.078156	0.000000		
0.574176	1.006620	0.577977	0.000000	1.133223	0.000000		
0.626374	1.006620	0.630520	0.000000	1.188291	0.000000		
0.678571	1.006620	0.683063	0.000000	1.243358	0.000000		
0.730769	1.006620	0.735607	0.000000	1.298425	0.000000		
0.782967	1.006620	0.788150	0.000000	1.353492	0.000000		
0.835165	1.006620	0.840693	0.000000	1.408559	0.000000		
0.887363	1.006620	0.893237	0.000000	1.463626	0.000000		
0.939560	1.006620	0.945780	0.000000	1.518693	0.000000		
0.991758	1.006620	0.998324	0.000000	1.573760	0.000000		
1.043956	1.006620	1.050867	0.074793	1.628828	0.000000		
1.096154	1.006620	1.103410	0.241982	1.683895	0.000000		
1.148352	1.006620	1.155954	0.463737	1.738962	0.000000		
1.200549	1.006620	1.208497	0.728896	1.794029	0.000000		
1.252747	1.006620	1.261040	1.031247	1.849096	0.000000		
1.304945	1.006620	1.313584	1.366676	1.904163	0.000000		
1.357143	1.006620	1.366127	1.732192	1.959230	0.000000		
1.409341	1.006620	1.418670	2.125497	2.014297	0.000000		
1.461538	1.006620	1.471214	2.544749	2.069364	0.000000		
1.513736	1.006620	1.523757	2.988433	2.124432	0.000000		
1.565934	1.006620	1.576300	3.455269	2.179499	0.000000		
1.618132	1.006620	1.628844	3.944163	2.234566	0.000000		
1.670330	1.006620	1.681387	4.454160	2.289633	0.000000		
1.722527	1.006620	1.733930	4.984420	2.344700	0.000000		

1.774725	1.006620	1.786474	5.534198	2.399767	0.000000
1.826923	1.006620	1.839017	6.102823	2.454834	0.000000
1.879121	1.006620	1.891560	6.689690	2.509901	0.000000
1.931319	1.006620	1.944104	7.294249	2.564969	0.000000
1.983516	1.006620	1.996647	7.915996	2.620036	0.000000
2.000000	1.006620	2.013240	8.554469	2.637425	0.000000

END FTABLE 1

END FTABLES

EXT SOURCES

<-Volume->	<Member>	SsysSgap<--Mult-->	Tran	<-Target vols>	<-Grp>	<-Member->	***	
<Name>	#	<Name>	#	tem strg<-factor->	strg	<Name>	# #	***
WDM	2	PREC	ENGL	0.944		PERLND	1 999	EXTNL PREC
WDM	2	PREC	ENGL	0.944		IMPLND	1 999	EXTNL PREC
WDM	1	EVAP	ENGL	1		PERLND	1 999	EXTNL PETINP
WDM	1	EVAP	ENGL	1		IMPLND	1 999	EXTNL PETINP
WDM	2	PREC	ENGL	0.944		RCHRES	1	EXTNL PREC
WDM	1	EVAP	ENGL	0.5		RCHRES	1	EXTNL POTEV
WDM	1	EVAP	ENGL	0.7		RCHRES	2	EXTNL POTEV

END EXT SOURCES

EXT TARGETS

<-Volume->	<-Grp>	<-Member->	<--Mult-->	Tran	<-Volume->	<Member>	Tsys	Tgap	Amd	***
<Name>	#	<Name>	#	#<-factor->	strg	<Name>	#	<Name>	tem strg	strg***
COPY	1	OUTPUT	MEAN	1 1	12.1	WDM	701	FLOW	ENGL	REPL
COPY	501	OUTPUT	MEAN	1 1	12.1	WDM	801	FLOW	ENGL	REPL
COPY	601	OUTPUT	MEAN	1 1	12.1	WDM	901	FLOW	ENGL	REPL
RCHRES	2	HYDR	RO	1 1	1	WDM	1000	FLOW	ENGL	REPL
RCHRES	2	HYDR	O	1 1	1	WDM	1001	FLOW	ENGL	REPL
RCHRES	2	HYDR	O	2 1	1	WDM	1002	FLOW	ENGL	REPL
RCHRES	2	HYDR	STAGE	1 1	1	WDM	1003	STAG	ENGL	REPL
RCHRES	1	HYDR	STAGE	1 1	1	WDM	1004	STAG	ENGL	REPL
RCHRES	1	HYDR	O	1 1	1	WDM	1005	FLOW	ENGL	REPL

END EXT TARGETS

MASS-LINK

<Volume>	<-Grp>	<-Member->	<--Mult-->	<Target>	<-Grp>	<-Member->	***	
<Name>	#	<Name>	#	#<-factor->	<Name>	#	#	***
MASS-LINK		2						
PERLND	PWATER	SURO		0.083333	RCHRES		INFLOW IVOL	
END MASS-LINK		2						
MASS-LINK		3						
PERLND	PWATER	IFWO		0.083333	RCHRES		INFLOW IVOL	
END MASS-LINK		3						
MASS-LINK		5						
IMPLND	IWATER	SURO		0.083333	RCHRES		INFLOW IVOL	
END MASS-LINK		5						
MASS-LINK		8						
RCHRES	OFLOW	OVOL	2		RCHRES		INFLOW IVOL	
END MASS-LINK		8						
MASS-LINK		12						
PERLND	PWATER	SURO		0.083333	COPY		INPUT MEAN	
END MASS-LINK		12						
MASS-LINK		13						
PERLND	PWATER	IFWO		0.083333	COPY		INPUT MEAN	
END MASS-LINK		13						
MASS-LINK		15						
IMPLND	IWATER	SURO		0.083333	COPY		INPUT MEAN	
END MASS-LINK		15						
MASS-LINK		17						
RCHRES	OFLOW	OVOL	1		COPY		INPUT MEAN	
END MASS-LINK		17						

```
    MASS-LINK      18
RCHRES      OFLOW  OVOL   2      COPY      INPUT  MEAN
    END MASS-LINK  18

    MASS-LINK      50
IMPLND      IWATER SURO      PERLND      EXTNL  SURLI
    END MASS-LINK  50

END MASS-LINK

END RUN
```



*Pre-Project HSPF Message File*

## Mitigated HSPF Message File

ERROR/WARNING ID: 341 6

DATE/TIME: 1986/ 2/18 23: 0

RCHRES: 1

The volume of water in this reach/mixed reservoir is greater than the value in the "volume" column of the last row of RCHTAB(). To continue the simulation the table has been extrapolated, based on information contained in the last two rows. This will usually result in some loss of accuracy. If depth is being calculated it will also cause an error condition. Relevant data are:

NROWS	V1	V2	VOL
40	8.6974E+04	8.7697E+04	8.8512E+04

---

ERROR/WARNING ID: 341 5

DATE/TIME: 1986/ 2/18 23: 0

RCHRES: 1

Calculation of relative depth, using Newton's method of successive approximations, converged to an invalid value (not in range 0.0 to 1.0). Probably ftable was extrapolated. If extrapolation was small, no problem. Remedy; extend ftable. Relevant data are:

A	B	C	RDEP1	RDEP2	COUNT	
0.0000E+00	8.7697E+04	-1.866E+05	2.1275	2.1275	2.1275	2

---

ERROR/WARNING ID: 341 6

DATE/TIME: 1995/ 1/10 9: 0

RCHRES: 1

The volume of water in this reach/mixed reservoir is greater than the value in the "volume" column of the last row of RCHTAB(). To continue the simulation the table has been extrapolated, based on information contained in the last two rows. This will usually result in some loss of accuracy. If depth is being calculated it will also cause an error condition. Relevant data are:

NROWS	V1	V2	VOL
40	8.6974E+04	8.7697E+04	9.1323E+04

---

ERROR/WARNING ID: 341 5

DATE/TIME: 1995/ 1/10 9: 0

RCHRES: 1

Calculation of relative depth, using Newton's method of successive approximations, converged to an invalid value (not in range 0.0 to 1.0). Probably ftable was extrapolated. If extrapolation was small, no problem. Remedy; extend ftable. Relevant data are:

A	B	C	RDEP1	RDEP2	COUNT	
0.0000E+00	8.7697E+04	-5.276E+05	6.0164	6.0164E+00	6.0164E+00	2

## *Disclaimer*

### *Legal Notice*

This program and accompanying documentation are provided 'as-is' without warranty of any kind. The entire risk regarding the performance and results of this program is assumed by End User. Clear Creek Solutions Inc. and the governmental licensee or sublicensees disclaim all warranties, either expressed or implied, including but not limited to implied warranties of program and accompanying documentation. In no event shall Clear Creek Solutions Inc. be liable for any damages whatsoever (including without limitation to damages for loss of business profits, loss of business information, business interruption, and the like) arising out of the use of, or inability to use this program even if Clear Creek Solutions Inc. or their authorized representatives have been advised of the possibility of such damages. Software Copyright © by : Clear Creek Solutions, Inc. 2005-2013; All Rights Reserved.

Clear Creek Solutions, Inc.  
6200 Capitol Blvd. Ste F  
Olympia, WA. 98501  
Toll Free 1(866)943-0304  
Local (360)943-0304

[www.clearcreeksolutions.com](http://www.clearcreeksolutions.com)

**Appendix D-1: Residential Sites: Low Impact Development (LID) Credits and Treatment BMP Sizing Calculations**

Name of Drainage Shed:  Fill in Blue Highlighted boxes  
 Location of project:

**Step 1 - Open Space and Pervious Area Credits**

Is your project within the drainage area of a common drainage plan that includes open space? If not, skip to 1 b.

**1 a. Common Drainage Plan Area**  acres  $A_{CDP}$

**Common Drainage Plan Open Space (Off-project)**  acres  $A_{OS}$  **see area example below**

a. Natural storage reservoirs and drainage corridors  acres  
 b. Buffer zones for natural water bodies  acres  
 c. Natural areas including existing trees, other vegetation, and soil  acres  
 d. Common landscape area/park  acres  
 e. Regional Flood Control/Drainage basins  acres

**1 b. Project Drainage Shed Area (Total)**  acres  $A$

**Project-Specific Open Space (In-project, communal)\*\***  acres  $A_{PSOS}$  **see area example below**

a. Natural storage reservoirs and drainage corridors  acres  
 b. Buffer zones for natural water bodies  acres  
 c. Natural areas including existing trees, other vegetation, and soil  acres  
 d. Landscape area/park  acres  
 e. Flood Control/Drainage basins  acres

\*\* Doesn't include impervious areas within individual lots and surrounding individual units. That is accounted for below using Form D-1a in Step 2.

**Area with Runoff Reduction Potential**  $A - A_{PSOS} =$   acres  $A_T$

**Number of Units in  $A_T$**

**Number of units per acre in  $A_T$**   $DU/A_T =$    $DUA$

**Assumed Initial Impervious Fraction of  $A_T$**    $I$   
 (determined using Table D-1a)

**Open Space & Pervious Area LID Credit (Step 1)**  
 $(A_{OS}/A_{CDP} + A_{PSOS}/A) \times 100 =$   pts

Dwelling units per acre	Imperviousness
1	0.17
2	0.25
3,4	0.35
5,6	0.40
7	0.50
8,9	0.55
10-14	0.60
15-20	0.70

	<b>A - Drainage Shed Area</b>
	<b><math>A_{PSOS}</math> Parks and Open Space</b>
	<b><math>A_T</math> - Area with Runoff Reduction Potential</b>

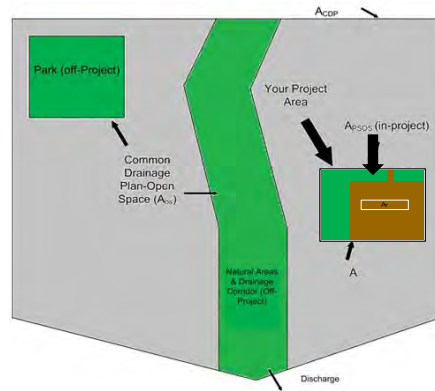
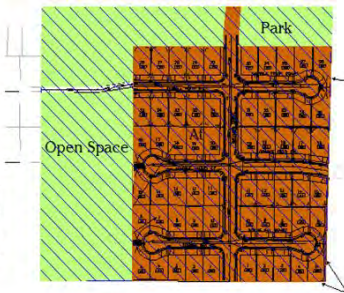

**Step 2 - Runoff Reduction Credits**

Runoff Reduction Measures		Effective Area Managed ( $A_C$ )	
<b>Disconnected Roof Drains</b> (see Fact Sheet)	use Form D-1a for credits	<input type="text" value="1.48"/>	acres
<b>Disconnected Pavement</b> (see Fact Sheet)	use Form D-1b for credits	<input type="text" value="0.45"/>	acres
<b>Interceptor Trees</b> (see Fact Sheet)	use Form D-1c for credits	<input type="text" value="0.14"/>	acres
<b>Alternative Driveway Design</b> (see Fact Sheet)	use Form D-1d for credits	<input type="text" value="0.00"/>	acres
<b>Total Effective Area Managed (Credit Area)</b>		<input type="text" value="2.08"/>	acres EAM

**Runoff Reduction Credit (Step 2)**  
 $(A_C / A_T) \times 100 =$   pts

**Form D-1a: Disconnected Roof Drains Worksheet**

See Fact Sheet for more information regarding Disconnected Roof Drain credit guidelines

Effective Area Managed (A<sub>c</sub>)

1. Determine efficiency Multiplier

Runoff is directed to a dispersal trench or dry well (Type A and B soils only) 1.00

Runoff is directed across landscaping, determine setback

25 ft +	Use multiplier of	1.00
≥ 20 and < 25 ft	Use multiplier of	0.90
≥ 15 and < 20 ft	Use multiplier of	0.70
≥ 10 and < 15 ft	Use multiplier of	0.45
≥ 5 and < 10 ft	Use multiplier of	0.25

Efficiency Multiplier →  Box J1

2. Determine percentage of roof drains disconnected

→  Box J2

3. Select project density in dwelling units per acre:

1	Use reduction factor of	0.08
2	Use reduction factor of	0.13
3,4	Use reduction factor of	0.19
5,6	Use reduction factor of	0.23
7	Use reduction factor of	0.29
8,9	Use reduction factor of	0.33
10-14	Use reduction factor of	0.37
15-20	Use reduction factor of	0.44

Reduction Factor →  Box J3

4. Determine Area Managed

Multiply Box J3 by A<sub>T</sub>, and enter the result in Box J4  acres Box J4

5. Multiply Boxes J1, J2 and J4, and enter 60% of the result in Box J

acres Box J

This is the amount of area credit to enter into the "Disconnected Roof Drains" Box of Form D-1

**Form D-1b: Disconnected Pavement Worksheet**

See Fact Sheet for more information regarding NDC Pavement credit guidelines

Effective Area Managed (A<sub>c</sub>)

**Divided Sidewalks**

1. Determine percentage of units with divided Sidewalks

Box K1

Multiply Box K1, A<sub>T</sub>, and 0.04 and enter 60% of the result in Box K

acres Box K

This is the amount of area credit to enter into the "Disconnected Pavement" Box of Form D-1

**Form D-1c: Interceptor Tree Worksheet**

See Fact Sheet for more information regarding Interceptor Tree credit guidelines

Effective Area Managed (A<sub>c</sub>)

**New Evergreen Trees**

1. Enter number of new evergreen trees that qualify as Interceptor Trees in Box L1.

trees Box L1

2. Multiply Box L1 by 200 and enter result in Box L2

sq. ft. Box L2

**New Deciduous Trees**

3. Enter number of new deciduous trees that qualify as Interceptor Trees in Box L3.

trees Box L3

4. Multiply Box L3 by 100 and enter result in Box L4

sq. ft. Box L4

**Existing Tree Canopy**

5. Enter square footage of existing tree canopy that qualifies as Existing Tree canopy in Box L5.

sq. ft. Box L5

6. Multiply Box L5 by 0.5 and enter the result in Box L6

sq. ft. Box L6

**Total Interceptor Tree Credits**

Add Boxes L2, L4, and L6 and enter it into Box L7

sq. ft. Box L7

Divide Box L7 by 43,560 and multiply by 20% to get effective area managed and enter the result in Box L8

acres Box L8

This is the amount of area credit to enter into the "Interceptor Trees" Box of Form D-1

**Form D-1d: Alternative Driveway Design**

See Fact Sheet for more information regarding Alternative Driveway Design credit guidelines

1. Select type of driveway

Pervious Driveway:	Multiplier:
Cobblestone Block P	0.40
Pervious Concrete/A	0.60
Porous Pavement	0.75
Porous Gravel Pavement &	
Not Directly-connected	1.00

Box M1

2. Determine percentage of units with Alternative Driveways:

Box M2

4. Multiply Boxes M1, M2, A<sub>T</sub> and 0.04, and enter the result in Box M

This is the amount of area credit to enter into the "Alternative Driveway Design" Box of Form D-1

acres

**Step 3 - Runoff Management Credits**

**Capture and Use Credits**

**Impervious Area Managed by Rain barrels, Cisterns, and automatically-emptied systems**

(see Fact Sheet)

enter gallons, for simple rain barrels  acres

**Automated-Control Capture and Use System**

(see Fact Sheet, then enter impervious area managed by the system)

acres

**Bioretention/Infiltration Credits**

**Impervious Area Managed by Bioretention BMPs**

(see Fact Sheet)

Bioretention Area  sq ft  
 Subdrain Elevation  inches  
 Ponding Depth, inches  inches  acres

**Impervious Area Managed by Infiltration BMPs**

(see Fact Sheet)

Drawdown Time, hrs  drawdown\_hrs\_inf  
 Soil Infiltration Rate, in/hr  soil\_inf\_rate  
 Sizing Option 1: Capture Volume, acre-ft  capture\_vol\_inf  acres  
 Sizing Option 2: Infiltration BMP surface area, sq ft  soil\_surface\_area  acres  
 Basin or trench?  approximate BMP depth  ft

**Impervious Area Managed by Amended Soil or Mulch Beds**

(see Fact Sheet)

Mulched Infiltration Area, sq ft  mulch\_area  acres

**Total Effective Area Managed by Capture-and-Use/Bioretention/Infiltration BMPs**

A<sub>LIDC</sub>

**Runoff Management Credit (Step 3)**

A<sub>LIDC</sub>/A<sub>T</sub>\*200 =  pts

**Total LID Credits (Step 1+2+3)**

LID compliant, check for treatment sizing in Step 4

**Does project require hydromodification management? If yes, proceed to using SachM.**

**Adjusted Area for Flow-Based, Non-LID Treatment**

A<sub>T</sub> - A<sub>C</sub> - A<sub>LIDC</sub> =  A<sub>AT</sub>

**Adjusted Impervious Fraction of A for Volume-Based, Non-LID Treatment**

(A<sub>T</sub>\*I - A<sub>C</sub> - A<sub>LIDC</sub>) / A =  I<sub>A</sub>

**STOP: No additional treatment needed**

**Step 4a Treatment - Flow-Based (Rational Method)**

**Form D-1e**

Calculate treatment flow (cfs):

Flow = Runoff Coefficient x Rainfall Intensity x Adjusted Treatment Area

Determine C Factor using Table D-1b

C

Determine i using Table D-1c (Rainfall Intensity)

i

A<sub>AT</sub> from Step 2

A<sub>AT</sub>

Flow = C \* i \* A<sub>AT</sub>  cfs

**TABLE D-1b**

Development Type	Runoff Coefficient (Rational), C
Single-family areas	0.50
Multi-units, detached	0.60
Apartment dwelling areas	0.70
Multi-units, attached	0.75
User Specified	0.00

**Table D-1c**

Rainfall Intensity	
Roseville	i = 0.20 in/hr
Sacramento	i = 0.18 in/hr
Folsom	i = 0.20 in/hr

**Step 4b Treatment - Volume-Based (ASCE-WEF)**

Calculate water quality volume (Acre-Feet):

$$WQV = \text{Area} \times \text{Maximized Detention Volume (P}_0\text{)}$$

Obtain A from Step 1

A

hrs

Specified Draw Down time

Obtain P<sub>0</sub>: Maximized Detention Volume from figures E-1 to E-4 in Appendix E of this manual using I<sub>a</sub> from Step 2.

P<sub>0</sub>

Calculate treatment volume (acre-ft):

$$\text{Treatment volume} = A \times (P_0 / 12)$$

Acre-Feet

v06232012

## Stormwater Planter

Table SP-3. Design Data Summary Sheet for Stormwater Planter

Designer: John Smith Date: 3/17/2014  
Company: ABCD Engineering  
Project: Sutter Memorial  
Location: Lots B, C, D, and E (designed and modeled as one combined BMP)

### 1a. Determine Design Water Quality Volume

a. Tributary drainage area Area = 609,840 ft<sup>2</sup>  
b. Water Quality Volume WQV = 32,525 ft<sup>3</sup>

### 1b. Adjust Volume Up for Hydromodification Management (If Applicable) Based upon SAHM Modeling

a. Water Quality Volume based on SAHM modeling V = 43,848 ft<sup>3</sup>  
b. SAHM Model Demonstrates Compliance with Flow Duration Standards (Yes or No) Yes

### 2. Design average surcharge depth (d<sub>s</sub>)

d<sub>s</sub> = 6-12 inches (0.5-1 foot) d<sub>s</sub> = 1.0 ft

### 3. Design Planter Surface Area (A<sub>s</sub>)

A<sub>s</sub> = WQV/d<sub>s</sub> A<sub>s</sub> = 43,848 ft<sup>2</sup>

### 4. Base Course Layers

a. Topsoil (6 in. minimum) 6 in  
b. Sand/Peat Layer (18 in. minimum) 18 in  
c. Gravel Layer (9 in. minimum) 9 in

### 5. Planter Type (check type used)

Infiltration without underdrain  Infiltration with underdrain  
 Flow-through with impermeable liner

### 6. Vegetation (describe) Grass

### 7. Overflow Device (check type used or describe "Other")

Drop inlet  Standpipe  
 Other 10" Riser

Notes: \_\_\_\_\_



**Sample (Commercial) - Stormwater Quality Compliance Package  
(Sacramento County)**

*The following information is presented for example purposes only  
and may not be the current version. The other  
permitting agencies in the region may use different forms.  
Contact the local permitting agency for their submittal requirements.*

Notes to Reader Regarding Auburn Blvd. Example Project:

### **Design and Modeling Assumptions**

1. Project Site is assumed 4.34 acres of Type D Grass in Pre Development.
2. Hydromodification analysis has been performed for demonstration purposes only. The physical address for the project is in an area that is exempt from hydromodification analysis.
3. Water quality mitigation for the asphalt parking area (2.8 acres) is provided by the use of permeable pavement for the perimeter parking stalls, which total collectively approximately 0.80 acres. Water quality mitigation for the building footprint area (0.44 acres) is provided by means of a 90' bioswale and underground storage chamber connected in series.
4. The storage area underneath the porous pavement section is assumed 24" thick, with a native infiltration rate of 0.07" per hour (Type D Soils). A 3" perforated subdrain system is elevated 1' off the bottom of the pavement subgrade.
5. The porous pavement subgrade is assumed to be constructed flat
6. Point of compliance #2 is a duplicate of POC #1. It is used only to generate an unmitigated post development condition for use in the LID points tabulation within SAHM. In SAHM, LID points are determined based on the calculated volume reduction compared with the unmitigated condition (see Chapter 5 for more information regarding SAHM LID points).

### **Results**

1. Project "passes" hydromodification compliance standard for POC #1. Reader should disregard "failing" results for POC #2. (That refers only to the unmitigated condition, which we intuitively would expect not to "pass.")
2. Computed LID points are found at the back of the report. A total of 207 points have been earned with the proposed design. The project exceeds the 100 point minimum for LID compliance. Separate Design Data Summary Sheets are provided to demonstrate compliance with treatment requirements for the 85<sup>th</sup> percentile event.

**Sacramento County Supplemental Application:  
Preliminary Stormwater Quality Compliance Form**

*This form is provided for example purposes only.*

*Check with your local permitting agency for copies of forms and procedures appropriate for your project site.*

**1) Project Information**

Applicant Name: Auto Dealer Phone Number: 916-867-5309  
Address: 123 Elm Road  
Project Contact: Jim Anderson Phone Number: 916-867-5309  
Project name: Auto Dealership Assessor Parcel Number(s): 123-4567-890  
Site Address: 360 Auburn Blvd., Sacramento, CA 95818

Project Category (check all that apply):

**Refer to Design Manual Table 3-2 for Priority Project Categories**

- |  |   |   |
|--|---|---|
| <input type="checkbox"/> Residential (Single Family)       | <input type="checkbox"/> Retail Gasoline Outlet | <input type="checkbox"/> Hillside Development   |
| <input type="checkbox"/> Residential (Multi-Family)        | <input type="checkbox"/> Restaurant             | <input checked="" type="checkbox"/> Parking Lot |
| <input checked="" type="checkbox"/> Commercial Development | <input type="checkbox"/> Industrial Development |   |
| <input type="checkbox"/> Automotive Repair Shop            | <input type="checkbox"/> Street/Road            |   |

Project Gross Acres: 4.34 Project Net Acres: 4.34  
Existing Impervious Surface Area: 0.00 Proposed Impervious Surface Area: 3.24  
Project Density (Residential Only): N/A Proposed Pervious Surface Area: 1.10  
Watershed or Receiving Water: Arcade Creek  
303(d) Listed Water Bodies: Arcade Creek  
TMDLs: Chlorpyrifos and Diazinon

**2) Source Controls** (check source control measure or applicable pollutant sources, check Design Manual Chapter 4 for more information on source control measures)

**Refer to Design Manual Table 3-2 for Requirements**

- |   |  |
|---|--|
| <input checked="" type="checkbox"/> Storm Drain Message and Signage | <input type="checkbox"/> Outdoor Work Areas                |
| <input type="checkbox"/> Fueling Areas                              | <input type="checkbox"/> Vehicle/Equipment Wash Areas      |
| <input checked="" type="checkbox"/> Loading/Unloading Areas         | <input checked="" type="checkbox"/> Waste Management Areas |
| <input type="checkbox"/> Outdoor Storage Areas                      | <input type="checkbox"/> Other. Describe: _____            |

---

### 3) Low Impact Development Measures

**Refer to Design Manual Table 3-2 for Requirements**

Will LID measures be utilized for this project?  Yes  No

If yes, check selected LID measures below; attach completed worksheet (Design Manual Appendix D).

- Alternative Driveway Design
  - Disconnected Roof Drains
  - Disconnected Pavement
  - Green Roof
  - Interceptor Trees
  - Porous Pavement
  - Other. Describe: \_\_\_\_\_
- 

### 4) Stormwater Quality Treatment Requirements

**Refer to Design Manual Table 3-2 for Requirements**

Is treatment required?  Yes  No

If no, form is complete with signature. If yes, complete this section.

Indicate number of drainage subwatersheds for 2  
the site: \_\_\_\_\_

Early consideration of stormwater quality during site planning may reduce the overall cost of treatment controls. Low Impact Development (LID) methods and innovative design options can reduce the size of treatment options. In addition, early consideration allows for non-proprietary treatment options that can significantly reduce construction and maintenance costs.

---

### 5) Attach Project Overview and Stormwater Quality Narrative

Include Project description indicating nature of project (e.g., is it a newly developing site, replacement of a previously developed site, is it an infill site). Describe activities planned for site that may impact water quality such as a retail gasoline outlet as part of a development. Describe selected treatment options. Developers should keep in mind that proprietary devices require extensive maintenance by the owners of the property and do not qualify for LID credit, and should consider alternative treatment measures first. Project description should be no more than 1 page relating to stormwater quality.

#### Auto Dealership – Project Description

**The auto dealership development is located within the County of Sacramento. The project is 4.34 acres and includes one large building and an associated parking lot. Approximately 0.8 acres of porous pavement is proposed in the perimeter parking spaces. A bioswale and underground storage chamber are also proposed to mitigated rooftop runoff from the proposed building.**

**The existing property is undeveloped.**

**The project is not located in an HMP exempt area, it is not a previously approved project, it does not discharge directly to an exempt channel, and it does not meet the infill exemption requirements.**

Include annotated copy of Figure 3-1 of the Design Manual demonstrating applicability of stormwater quality requirements.

Include a copy of the discretionary level conditions of approval (if applicable).

---

**6) Attach Site Plans\* and/or Drawings Showing:**

- Existing and natural hydrologic features
- Existing and proposed drainage system (including material, size, slope, and invert elevations)
- Locations where site discharges to municipal storm drain system and/or receiving waters
- Proposed grades/contours (agency may specify contour interval)
- Proposed drainage subwatersheds including (**Refer to item #4, if treatment is required**)
  - Name of subwatershed
  - Existing amount of pervious and impervious areas
  - Proposed amount of pervious and impervious areas
  - Proposed treatment option(s) for each subwatershed
  - WQV or WQF to be treated
- Pollutant source areas including loading docks, food service areas, refuse areas, outdoor processes and storage, vehicle cleaning, repair or maintenance, fuel dispensing, equipment washing, etc.
- Proposed design features to minimize impervious areas, applicable LID techniques, innovative design, and all treatment options selected.
- Details for post-construction control measures, including the following information, where applicable:
  - Dimensions and setbacks from property lines and structures
  - Profile view, including typical cross-sections and dimensions
  - Water surface elevations/freeboard
  - Inlets, outlet structures, and release points
  - Vegetation & growing medium specifications, including provisions for temporary irrigation if needed
  - Specifications for construction materials, such as filter fabric and infiltration materials
  - Installation requirements

\*Note: Plans will not be checked for adequacy of treatment options until design review of drainage system. For information related to correct sizing and other requirements refer to *Stormwater Quality Design Manual for the Sacramento Region*.

---

**7) Attach HMP Calculations (SAHM Output Report):**

- Include SAHM output summary report demonstrating compliance with HMP flow duration criteria.
- 

**8) Attach LID Credit Backup:**

- Include LID credit worksheet for either Residential or Commercial development (as applicable), or other backup documentation of LID credits.
- 

**9) Attach Design Data Summary Sheets:**

- Include miscellaneous treatment calculations for any BMPs that are not already included in item 7 (HMP calculations) or item 8 (LID Credit Spreadsheet) above.

**10) List Subwatersheds and Selected Stormwater Quality Measures (as required)**

Subwatershed Name	Total Subwatershed Area		Flow (cfs) or Volume (ft <sup>3</sup> )	Control Measures Selected (for Hydromodification Management, LID, and/or Treatment)
	Impervious Area	Pervious Area		
1	0.44		.08 cfs	90' Bioswale and Underground Storage
	0.44	0.00		
2	3.90		7,786 ft <sup>3</sup>	Porous pavement and subsurface storage
	2.80	1.10		

**11) Signature**

Print Name: Jim Anderson Indicate Owner or Title: Owner

Signature: \_\_\_\_\_ Date: March 17, 2014

\*Control measures may be those included in the *Stormwater Quality Design Manual for the Sacramento Region* or alternative measures. For projects proposing use of control measures not specified in the Design Manual, the review and approval process may take longer. Also, slight variations to design criteria stated in the manual may be approved on occasion, provided the agency determines that performance of the facility itself or other site structures/features is not compromised. For agencies in Sacramento County, proposals of alternative proprietary structural devices may be accepted if the manufacturer can satisfy the agencies' protocol or the property owner agrees to conduct a pilot scale monitoring study.

**To avoid delays, all alternative proposals should be discussed with the stormwater quality staff at the permitting agency as early as possible in the planning stages of the project, preferably at the pre-application meeting.**

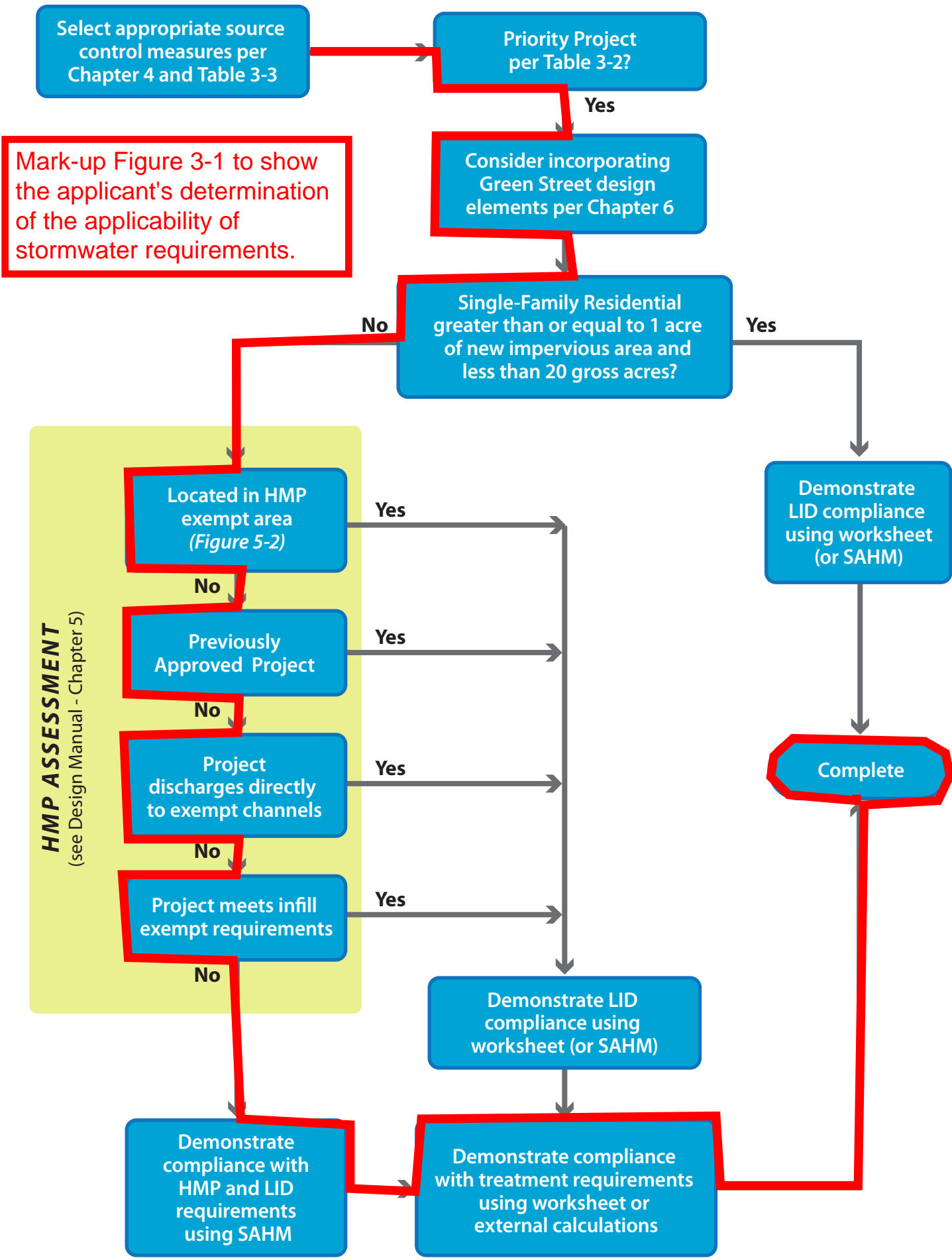

Select appropriate source control measures per Chapter 4 and Table 3-3

Priority Project per Table 3-2?

Yes

Consider incorporating Green Street design elements per Chapter 6

Mark-up Figure 3-1 to show the applicant's determination of the applicability of stormwater requirements.

Single-Family Residential greater than or equal to 1 acre of new impervious area and less than 20 gross acres?

No

Yes

Demonstrate LID compliance using worksheet (or SAHM)

Located in HMP exempt area (Figure 5-2)

Yes

No

Previously Approved Project

Yes

No

Project discharges directly to exempt channels

Yes

No

Project meets infill exempt requirements

Yes

No

HMP ASSESSMENT (see Design Manual - Chapter 5)

Demonstrate LID compliance using worksheet (or SAHM)

Demonstrate compliance with HMP and LID requirements using SAHM

Demonstrate compliance with treatment requirements using worksheet or external calculations

Complete

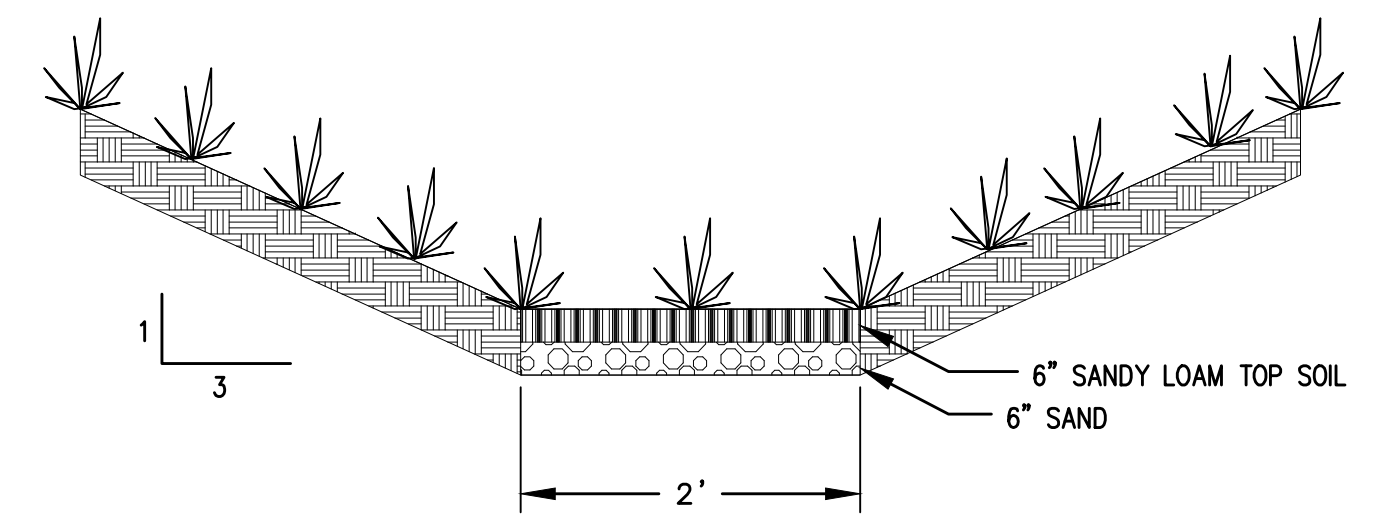
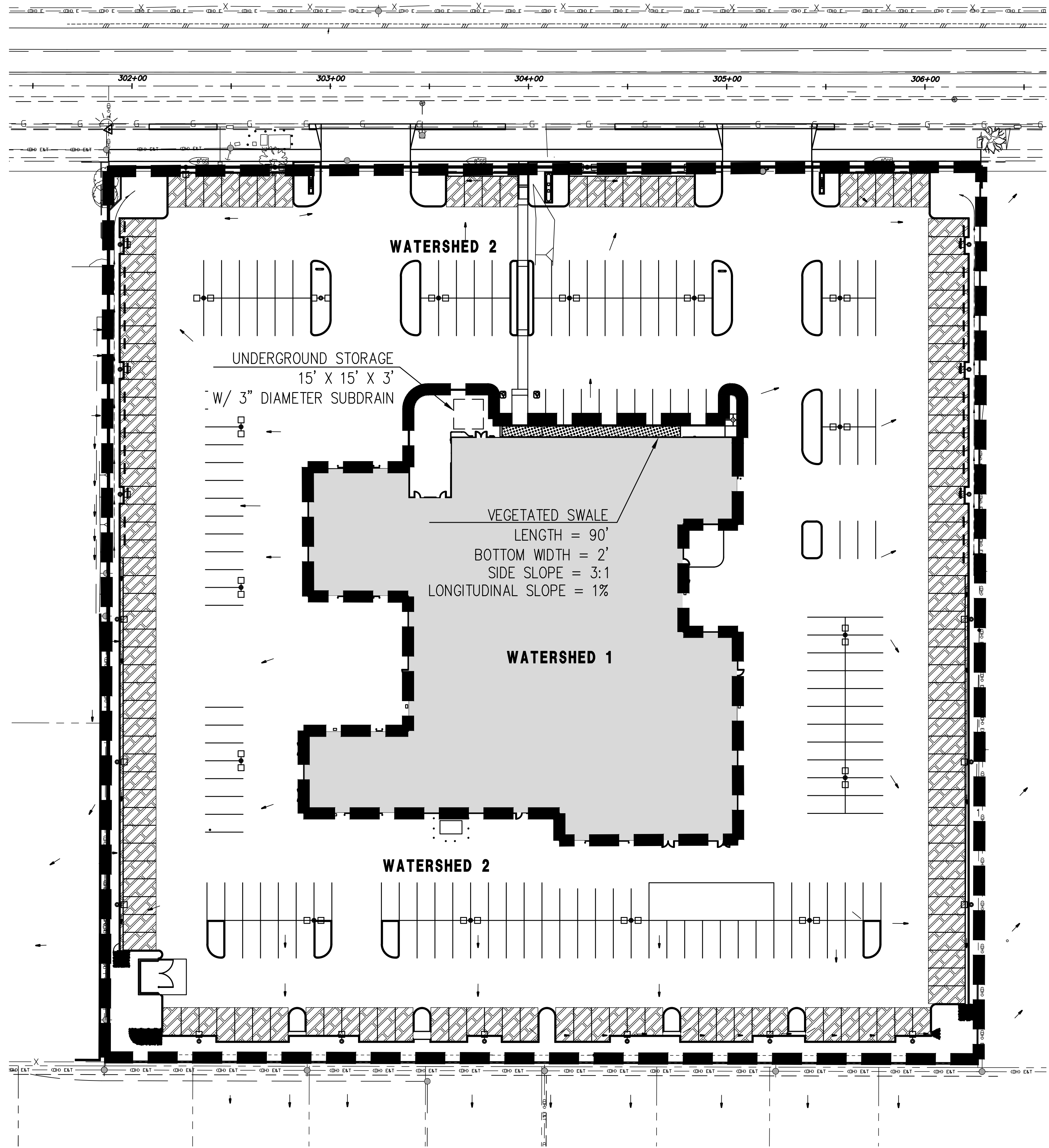

**VEGETATED SWALE**  
N.T.S.

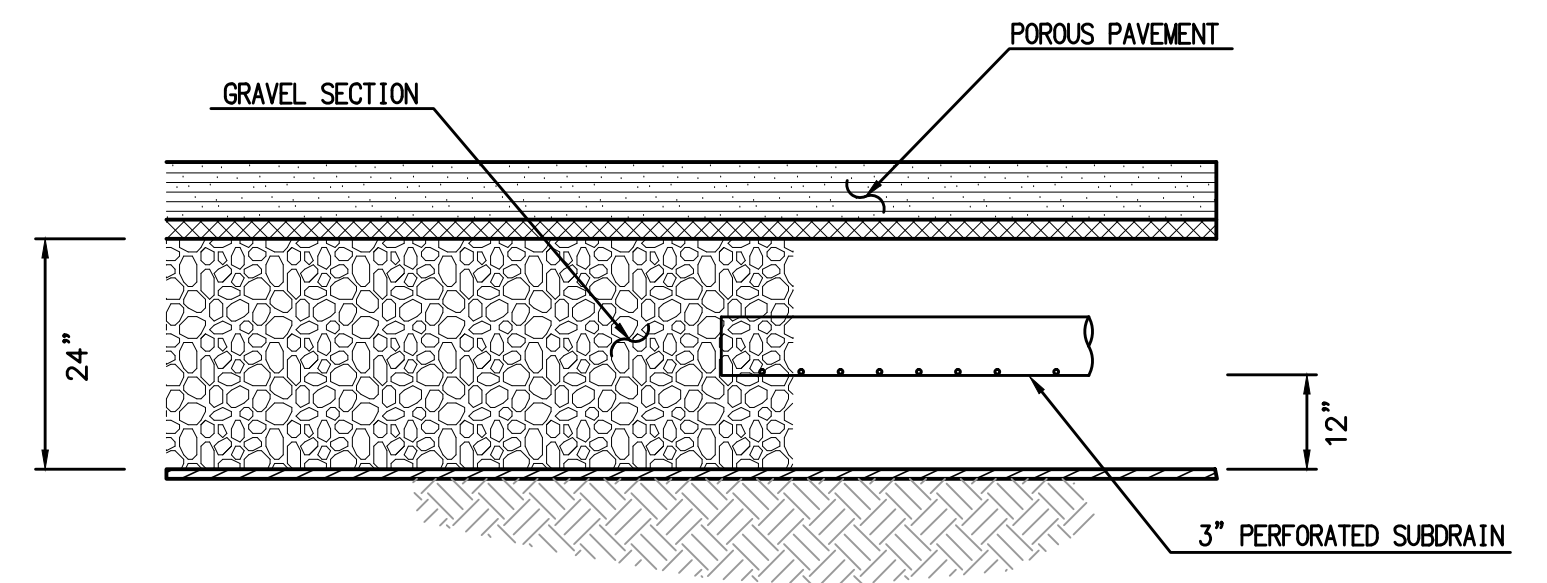

**POROUS PAVEMENT SECTION**  
N.T.S.

**POST CONSTRUCTION MEASURES**

SHED	EXISTING PERVIOUS	EXISTING IMPERVIOUS	PROPOSED PERVIOUS	PROPOSED IMPERVIOUS	TOTAL AREA	WQF/WQV	TREATMENT
#1	0.44 ACRES	0.00 ACRES	0.00 ACRES	0.44 ACRES	0.44 ACRES	0.08 CFS	VEGETATED SWALE
#2	3.90 ACRES	0.00 ACRES	1.10 ACRES	2.80 ACRES	3.90 ACRES	7,786 CF	POROUS PAVEMENT SUBGRADE

**LEGEND**

- POROUS PAVEMENT (0.80 ACRES TOTAL)
- VEGETATED SWALE (90 FEET)
- UNDERGROUND STORAGE (675 CUBIC FEET)
- DRAINAGE BASIN
- FLOW DIRECTION
- PROPOSED BUILDING

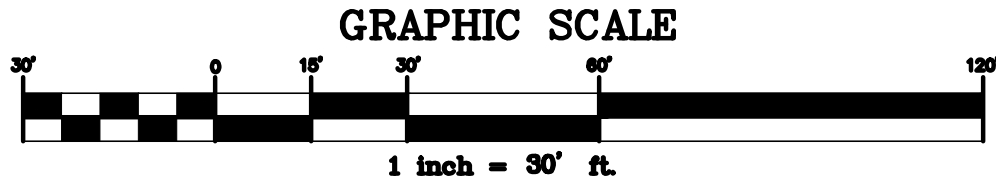

**Post Construction Control Measure Compliance**

I hereby certify that the Post Construction Control Measures were constructed as shown on the plans approved by the County of Sacramento.

Project Engineer: \_\_\_\_\_ R.C.E. : \_\_\_\_\_ Date \_\_\_\_\_

7					
6					
5					
4					
3					
2					
1					
NUMBER	DESCRIPTION	ENGR INIT	COUNTY APPROVAL BY	DATE	REVISION BLK.

DRAWN BY: \_\_\_\_\_  
 DESIGNED BY: \_\_\_\_\_  
 CHECKED BY: \_\_\_\_\_  
 SCALE: 1" = 30'  
 DATE: \_\_\_\_\_ F.B. REF. \_\_\_\_\_

BENCH MARK  
 BM: \_\_\_\_\_ ELEV : -  
 \_\_\_\_\_ DATUM : -  
 (SEE SHEET 1)

PREPARED UNDER THE DIRECTION OF  
 \_\_\_\_\_ DATE \_\_\_\_\_

IMPROVEMENT PLANS FOR:  
**AUTO DEALERSHIP**  
 POST-CONSTRUCTION STORM WATER QUALITY PLAN  
 COUNTY OF SACRAMENTO, CALIFORNIA

JOB NUMBER \_\_\_\_\_



**SAHM**

**PROJECT REPORT**

## General Model Information

Project Name: Auburn Blvd Sample  
Site Name:  
Site Address: 3830 Auburn BLVD  
City: sacramento, ca  
Report Date: 3/17/2014  
Gage: RANCHO C  
Data Start: 1961/10/01  
Data End: 2004/09/30  
Timestep: Hourly  
Precip Scale: 0.94  
Version: 2013/12/06

## POC Thresholds

---

Low Flow Threshold for POC1: 25 Percent of the 2 Year  
High Flow Threshold for POC1: 10 Year

---

Low Flow Threshold for POC2: 25 Percent of the 2 Year  
High Flow Threshold for POC2: 10 Year

---

## Landuse Basin Data

### Pre-Project Land Use

#### Pre Development

Bypass: No

GroundWater: No

Pervious Land Use Acres  
D,Grass,Mod (1-2%) 4.34

Pervious Total 4.34

Impervious Land Use Acres

Impervious Total 0

Basin Total 4.34

Element Flows To:  
Surface

Interflow

Groundwater

DRAFT

## Duplicate Pre Develop

Bypass: No

GroundWater: No

Pervious Land Use Acres  
D,Grass,Mod (1-2%) 4.34

Pervious Total 4.34

Impervious Land Use Acres

Impervious Total 0

Basin Total 4.34

Element Flows To:  
Surface

Interflow

Groundwater

DRAFT

## Mitigated Land Use

### Traditional Asphalt Parking

Bypass:	No
Impervious Land Use	Acres
Imperv,Flat(0-1%) LAT	2.8
Element Flows To:	
Outlet 1	Outlet 2
Porous Pavement	1

DRAFT

## Perimeter Landscape

Bypass: No

GroundWater: No

Pervious Land Use Acres  
D,Grass,Mod (1-2%) .3

Element Flows To:  
Surface Interflow Groundwater

DRAFT

## Unmitigated Post

Bypass:	No
GroundWater:	No
Pervious Land Use D,Grass,Mod (1-2%)	Acres 0.3
Pervious Total	0.3
Impervious Land Use Imperv,Mod (1-2%)	Acres 4.04
Impervious Total	4.04
Basin Total	4.34

Element Flows To:	Interflow	Groundwater
Surface		

DRAFT

## Rooftop Area

Bypass:	No
Impervious Land Use	Acres
Imperv,Flat(0-1%) LAT	0.44
Element Flows To:	
Outlet 1	Outlet 2
90 Foot Bioswale Building Front	

DRAFT



*Routing Elements*  
*Pre-Project Routing*

DRAFT

## Mitigated Routing

### Porous Pavement 1

Pavement Area: 0.7998 ac. Pavement Length: 1742.00 ft.  
 Pavement Width: 20.00 ft.  
 Pavement slope 1:0 To 1  
 Pavement thickness: 2  
 Pour Space of Pavement: 0.4  
 Material thickness of second layer: 0  
 Pour Space of material for second layer: 0  
 Material thickness of third layer: 0  
 Pour Space of material for third layer: 0  
 Infiltration On  
 Infiltration rate: 0.07  
 Infiltration safety factor: 1  
 Total Volume Infiltrated (ac-ft): 163.63  
 Total Volume Through Riser (ac-ft): 17.041  
 Total Volume Through Facility (ac-ft): 180.672  
 Percent Infiltrated: 90.57  
 Element Flows To:  
 Outlet 1                      Outlet 2  
 Perimeter Landscape

Porous Pavement Hydraulic Table

Stage(ft)	Area(ac)	Volume(ac-ft)	Discharge(cfs)	Infilt(cfs)
0.0000	0.799	0.000	0.000	0.000
0.0278	0.800	0.008	0.000	0.056
0.0556	0.802	0.017	0.000	0.056
0.0833	0.803	0.026	0.000	0.056
0.1111	0.804	0.035	0.000	0.056
0.1389	0.805	0.044	0.000	0.056
0.1667	0.806	0.053	0.000	0.056
0.1944	0.807	0.062	0.000	0.056
0.2222	0.808	0.071	0.000	0.056
0.2500	0.809	0.080	0.000	0.056
0.2778	0.810	0.089	0.000	0.056
0.3056	0.812	0.098	0.000	0.056
0.3333	0.813	0.107	0.000	0.056
0.3611	0.814	0.116	0.000	0.056
0.3889	0.815	0.125	0.000	0.056
0.4167	0.816	0.134	0.000	0.056
0.4444	0.817	0.143	0.000	0.056
0.4722	0.818	0.152	0.000	0.056
0.5000	0.819	0.162	0.000	0.056
0.5278	0.820	0.171	0.000	0.056
0.5556	0.822	0.180	0.000	0.056
0.5833	0.823	0.189	0.000	0.056
0.6111	0.824	0.198	0.000	0.056
0.6389	0.825	0.207	0.000	0.056
0.6667	0.826	0.216	0.000	0.056
0.6944	0.827	0.226	0.000	0.056
0.7222	0.828	0.235	0.000	0.056
0.7500	0.829	0.244	0.000	0.056
0.7778	0.830	0.253	0.000	0.056
0.8056	0.832	0.262	0.000	0.056
0.8333	0.833	0.272	0.000	0.056

0.8611	0.834	0.281	0.000	0.056
0.8889	0.835	0.290	0.000	0.056
0.9167	0.836	0.300	0.000	0.056
0.9444	0.837	0.309	0.000	0.056
0.9722	0.838	0.318	0.000	0.056
1.0000	0.839	0.327	0.000	0.056
1.0278	0.840	0.337	0.039	0.056
1.0556	0.842	0.346	0.055	0.056
1.0833	0.843	0.356	0.068	0.056
1.1111	0.844	0.365	0.078	0.056
1.1389	0.845	0.374	0.088	0.056
1.1667	0.846	0.384	0.096	0.056
1.1944	0.847	0.393	0.104	0.056
1.2222	0.848	0.403	0.111	0.056
1.2500	0.849	0.412	0.118	0.056
1.2778	0.850	0.421	0.124	0.056
1.3056	0.852	0.431	0.130	0.056
1.3333	0.853	0.440	0.136	0.056
1.3611	0.854	0.450	0.142	0.056
1.3889	0.855	0.459	0.147	0.056
1.4167	0.856	0.469	0.152	0.056
1.4444	0.857	0.478	0.157	0.056
1.4722	0.858	0.488	0.162	0.056
1.5000	0.859	0.497	0.167	0.056
1.5278	0.860	0.507	0.171	0.056
1.5556	0.862	0.517	0.176	0.056
1.5833	0.863	0.526	0.180	0.056
1.6111	0.864	0.536	0.184	0.056
1.6389	0.865	0.545	0.188	0.056
1.6667	0.866	0.555	0.193	0.056
1.6944	0.867	0.565	0.197	0.056
1.7222	0.868	0.574	0.200	0.056
1.7500	0.869	0.584	0.204	0.056
1.7778	0.870	0.594	0.208	0.056
1.8056	0.872	0.603	0.212	0.056
1.8333	0.873	0.613	0.215	0.056
1.8611	0.874	0.623	0.219	0.056
1.8889	0.875	0.632	0.222	0.056
1.9167	0.876	0.642	0.226	0.056
1.9444	0.877	0.652	0.229	0.056
1.9722	0.878	0.662	0.233	0.056
2.0000	0.879	0.671	0.236	0.056
2.0278	0.880	0.696	0.316	0.056
2.0556	0.882	0.720	0.460	0.056
2.0833	0.883	0.745	0.646	0.056
2.1111	0.884	0.769	0.865	0.056
2.1389	0.885	0.794	1.114	0.056
2.1667	0.886	0.819	1.388	0.056
2.1944	0.887	0.843	1.685	0.056
2.2222	0.888	0.868	2.005	0.056
2.2500	0.889	0.893	2.345	0.056
2.2778	0.890	0.917	2.704	0.056
2.3056	0.892	0.942	3.082	0.056
2.3333	0.893	0.967	3.477	0.056
2.3611	0.894	0.992	3.888	0.056
2.3889	0.895	1.017	4.316	0.056
2.4167	0.896	1.041	4.759	0.056
2.4444	0.897	1.066	5.217	0.056

2.4722  
2.5000

0.898  
0.899

1.091  
1.116

5.689  
6.176

0.056  
0.056

DRAFT

## 90 Foot Bioswale Building Front

Bottom Length: 90.00 ft.  
 Bottom Width: 2.00 ft.  
 Manning's n: 0.1  
 Channel bottom slope 1: 0.01 To 1  
 Channel Left side slope 0: 3 To 1  
 Channel right side slope 2: 3 To 1  
 Discharge Structure  
 Riser Height: 0 ft.  
 Riser Diameter: 0 in.  
 Element Flows To:  
 Outlet 1                      Outlet 2  
 Vault 1

Channel Hydraulic Table

Stage(ft)	Area(ac)	Volume(ac-ft)	Discharge(cfs)	Infilt(cfs)
0.0000	0.004	0.000	0.000	0.000
0.0056	0.004	0.000	0.000	0.000
0.0111	0.004	0.000	0.001	0.000
0.0167	0.004	0.000	0.003	0.000
0.0222	0.004	0.000	0.005	0.000
0.0278	0.004	0.000	0.007	0.000
0.0333	0.004	0.000	0.010	0.000
0.0389	0.004	0.000	0.013	0.000
0.0444	0.004	0.000	0.017	0.000
0.0500	0.004	0.000	0.020	0.000
0.0556	0.004	0.000	0.024	0.000
0.0611	0.004	0.000	0.029	0.000
0.0667	0.005	0.000	0.033	0.000
0.0722	0.005	0.000	0.038	0.000
0.0778	0.005	0.000	0.043	0.000
0.0833	0.005	0.000	0.049	0.000
0.0889	0.005	0.000	0.055	0.000
0.0944	0.005	0.000	0.061	0.000
0.1000	0.005	0.000	0.067	0.000
0.1056	0.005	0.000	0.074	0.000
0.1111	0.005	0.000	0.080	0.000
0.1167	0.005	0.000	0.088	0.000
0.1222	0.005	0.000	0.095	0.000
0.1278	0.005	0.000	0.103	0.000
0.1333	0.005	0.000	0.111	0.000
0.1389	0.005	0.000	0.119	0.000
0.1444	0.005	0.000	0.127	0.000
0.1500	0.006	0.000	0.136	0.000
0.1556	0.006	0.000	0.145	0.000
0.1611	0.006	0.000	0.155	0.000
0.1667	0.006	0.000	0.164	0.000
0.1722	0.006	0.000	0.174	0.000
0.1778	0.006	0.000	0.184	0.000
0.1833	0.006	0.001	0.194	0.000
0.1889	0.006	0.001	0.205	0.000
0.1944	0.006	0.001	0.216	0.000
0.2000	0.006	0.001	0.227	0.000
0.2056	0.006	0.001	0.239	0.000
0.2111	0.006	0.001	0.250	0.000
0.2167	0.006	0.001	0.262	0.000

0.2222	0.006	0.001	0.275	0.000
0.2278	0.007	0.001	0.287	0.000
0.2333	0.007	0.001	0.300	0.000
0.2389	0.007	0.001	0.313	0.000
0.2444	0.007	0.001	0.327	0.000
0.2500	0.007	0.001	0.340	0.000
0.2556	0.007	0.001	0.354	0.000
0.2611	0.007	0.001	0.369	0.000
0.2667	0.007	0.001	0.383	0.000
0.2722	0.007	0.001	0.398	0.000
0.2778	0.007	0.001	0.413	0.000
0.2833	0.007	0.001	0.429	0.000
0.2889	0.007	0.001	0.444	0.000
0.2944	0.007	0.001	0.460	0.000
0.3000	0.007	0.001	0.477	0.000
0.3056	0.007	0.001	0.493	0.000
0.3111	0.008	0.001	0.510	0.000
0.3167	0.008	0.001	0.527	0.000
0.3222	0.008	0.002	0.545	0.000
0.3278	0.008	0.002	0.562	0.000
0.3333	0.008	0.002	0.580	0.000
0.3389	0.008	0.002	0.599	0.000
0.3444	0.008	0.002	0.617	0.000
0.3500	0.008	0.002	0.636	0.000
0.3556	0.008	0.002	0.656	0.000
0.3611	0.008	0.002	0.675	0.000
0.3667	0.008	0.002	0.695	0.000
0.3722	0.008	0.002	0.715	0.000
0.3778	0.008	0.002	0.736	0.000
0.3833	0.008	0.002	0.757	0.000
0.3889	0.009	0.002	0.778	0.000
0.3944	0.009	0.002	0.799	0.000
0.4000	0.009	0.002	0.821	0.000
0.4056	0.009	0.002	0.843	0.000
0.4111	0.009	0.002	0.865	0.000
0.4167	0.009	0.002	0.888	0.000
0.4222	0.009	0.002	0.911	0.000
0.4278	0.009	0.002	0.934	0.000
0.4333	0.009	0.003	0.958	0.000
0.4389	0.009	0.003	0.982	0.000
0.4444	0.009	0.003	1.006	0.000
0.4500	0.009	0.003	1.031	0.000
0.4556	0.009	0.003	1.056	0.000
0.4611	0.009	0.003	1.081	0.000
0.4667	0.009	0.003	1.107	0.000
0.4722	0.010	0.003	1.133	0.000
0.4778	0.010	0.003	1.159	0.000
0.4833	0.010	0.003	1.185	0.000
0.4889	0.010	0.003	1.212	0.000
0.4944	0.010	0.003	1.240	0.000
0.5000	0.010	0.003	1.267	0.000
0.5056	0.010	0.003	1.295	0.000

DRAFT

## Vault 1

Width: 15 ft.  
Length: 15 ft.  
Depth: 3 ft.  
Discharge Structure  
Riser Height: 0 ft.  
Riser Diameter: 0 in.  
Orifice 1 Diameter: 3 in. Elevation: 0 ft.  
Element Flows To:  
Outlet 1 Outlet 2

Vault Hydraulic Table

Stage(ft)	Area(ac)	Volume(ac-ft)	Discharge(cfs)	Infilt(cfs)
0.0000	0.005	0.000	0.000	0.000
0.0333	0.005	0.000	0.043	0.000
0.0667	0.005	0.000	0.061	0.000
0.1000	0.005	0.000	0.074	0.000
0.1333	0.005	0.000	0.086	0.000
0.1667	0.005	0.000	0.096	0.000
0.2000	0.005	0.001	0.105	0.000
0.2333	0.005	0.001	0.114	0.000
0.2667	0.005	0.001	0.122	0.000
0.3000	0.005	0.001	0.129	0.000
0.3333	0.005	0.001	0.136	0.000
0.3667	0.005	0.001	0.143	0.000
0.4000	0.005	0.002	0.149	0.000
0.4333	0.005	0.002	0.155	0.000
0.4667	0.005	0.002	0.161	0.000
0.5000	0.005	0.002	0.167	0.000
0.5333	0.005	0.002	0.172	0.000
0.5667	0.005	0.002	0.177	0.000
0.6000	0.005	0.003	0.183	0.000
0.6333	0.005	0.003	0.188	0.000
0.6667	0.005	0.003	0.193	0.000
0.7000	0.005	0.003	0.197	0.000
0.7333	0.005	0.003	0.202	0.000
0.7667	0.005	0.004	0.207	0.000
0.8000	0.005	0.004	0.211	0.000
0.8333	0.005	0.004	0.215	0.000
0.8667	0.005	0.004	0.220	0.000
0.9000	0.005	0.004	0.224	0.000
0.9333	0.005	0.004	0.228	0.000
0.9667	0.005	0.005	0.232	0.000
1.0000	0.005	0.005	0.236	0.000
1.0333	0.005	0.005	0.240	0.000
1.0667	0.005	0.005	0.244	0.000
1.1000	0.005	0.005	0.247	0.000
1.1333	0.005	0.005	0.251	0.000
1.1667	0.005	0.006	0.255	0.000
1.2000	0.005	0.006	0.258	0.000
1.2333	0.005	0.006	0.262	0.000
1.2667	0.005	0.006	0.266	0.000
1.3000	0.005	0.006	0.269	0.000
1.3333	0.005	0.006	0.272	0.000
1.3667	0.005	0.007	0.276	0.000

1.4000	0.005	0.007	0.279	0.000
1.4333	0.005	0.007	0.283	0.000
1.4667	0.005	0.007	0.286	0.000
1.5000	0.005	0.007	0.289	0.000
1.5333	0.005	0.007	0.292	0.000
1.5667	0.005	0.008	0.295	0.000
1.6000	0.005	0.008	0.299	0.000
1.6333	0.005	0.008	0.302	0.000
1.6667	0.005	0.008	0.305	0.000
1.7000	0.005	0.008	0.308	0.000
1.7333	0.005	0.009	0.311	0.000
1.7667	0.005	0.009	0.314	0.000
1.8000	0.005	0.009	0.317	0.000
1.8333	0.005	0.009	0.320	0.000
1.8667	0.005	0.009	0.322	0.000
1.9000	0.005	0.009	0.325	0.000
1.9333	0.005	0.010	0.328	0.000
1.9667	0.005	0.010	0.331	0.000
2.0000	0.005	0.010	0.334	0.000
2.0333	0.005	0.010	0.337	0.000
2.0667	0.005	0.010	0.339	0.000
2.1000	0.005	0.010	0.342	0.000
2.1333	0.005	0.011	0.345	0.000
2.1667	0.005	0.011	0.347	0.000
2.2000	0.005	0.011	0.350	0.000
2.2333	0.005	0.011	0.353	0.000
2.2667	0.005	0.011	0.355	0.000
2.3000	0.005	0.011	0.358	0.000
2.3333	0.005	0.012	0.361	0.000
2.3667	0.005	0.012	0.363	0.000
2.4000	0.005	0.012	0.366	0.000
2.4333	0.005	0.012	0.368	0.000
2.4667	0.005	0.012	0.371	0.000
2.5000	0.005	0.012	0.373	0.000
2.5333	0.005	0.013	0.376	0.000
2.5667	0.005	0.013	0.378	0.000
2.6000	0.005	0.013	0.381	0.000
2.6333	0.005	0.013	0.383	0.000
2.6667	0.005	0.013	0.386	0.000
2.7000	0.005	0.013	0.388	0.000
2.7333	0.005	0.014	0.390	0.000
2.7667	0.005	0.014	0.393	0.000
2.8000	0.005	0.014	0.395	0.000
2.8333	0.005	0.014	0.397	0.000
2.8667	0.005	0.014	0.400	0.000
2.9000	0.005	0.015	0.402	0.000
2.9333	0.005	0.015	0.404	0.000
2.9667	0.005	0.015	0.407	0.000
3.0000	0.005	0.015	0.409	0.000
3.0333	0.005	0.015	0.411	0.000
3.0667	0.000	0.000	0.413	0.000



# Analysis Results

## POC 1

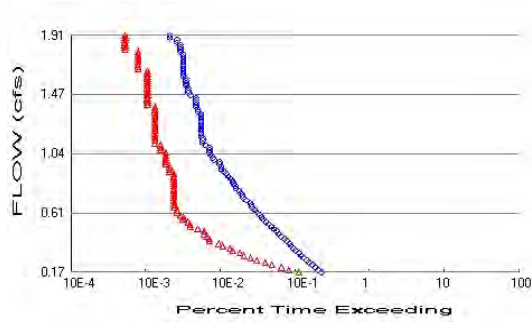

+ Pre-Project

x Mitigated

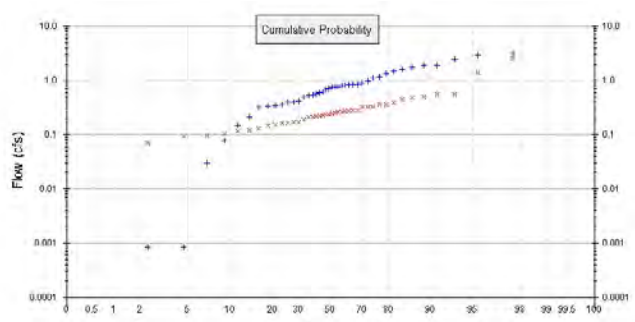

### Pre-Project Landuse Totals for POC #1

Total Pervious Area: 4.34  
 Total Impervious Area: 0

### Mitigated Landuse Totals for POC #1

Total Pervious Area: 0.3  
 Total Impervious Area: 4.039816

Flow Frequency Method: Log Pearson Type III 17B

### Flow Frequency Return Periods for Pre-Project. POC #1

Return Period	Flow(cfs)
2 year	0.699992
5 year	1.368109
10 year	1.907045
25 year	2.975886

### Flow Frequency Return Periods for Mitigated. POC #1

Return Period	Flow(cfs)
2 year	0.234126
5 year	0.366218
10 year	0.521446
25 year	1.546302

## Annual Peaks

### Annual Peaks for Pre-Project and Mitigated. POC #1

Year	Pre-Project	Mitigated
1962	0.764	0.284
1963	0.356	0.234
1964	0.078	0.155
1965	0.811	0.324
1966	0.030	0.096
1967	0.843	0.358
1968	0.211	0.106
1969	0.764	0.280
1970	0.612	0.231
1971	0.911	0.362
1972	0.001	0.071
1973	1.773	0.326
1974	0.561	0.164
1975	0.689	0.216

1976	0.001	0.094
1977	0.001	0.070
1978	0.849	0.260
1979	0.394	0.170
1980	1.343	0.320
1981	0.148	0.149
1982	1.483	0.482
1983	1.874	0.494
1984	0.700	0.245
1985	0.402	0.213
1986	2.954	1.398
1987	0.324	0.114
1988	0.589	0.168
1989	0.984	0.256
1990	0.748	0.187
1991	0.528	0.273
1992	1.101	0.273
1993	0.847	0.208
1994	0.414	0.129
1995	3.114	2.484
1996	1.935	0.450
1997	2.421	0.544
1998	1.594	0.545
1999	0.498	0.224
2000	1.165	0.384
2001	0.342	0.119
2002	0.338	0.167
2003	0.524	0.261
2004	0.820	0.220

### Ranked Annual Peaks

Ranked Annual Peaks for Pre-Project and Mitigated. POC #1

Rank	Pre-Project	Mitigated
1	3.1143	2.4841
2	2.9540	1.3982
3	2.4206	0.5447
4	1.9348	0.5442
5	1.8737	0.4941
6	1.7727	0.4818
7	1.5943	0.4500
8	1.4829	0.3844
9	1.3426	0.3622
10	1.1647	0.3580
11	1.1010	0.3262
12	0.9836	0.3236
13	0.9106	0.3195
14	0.8490	0.2840
15	0.8467	0.2799
16	0.8425	0.2732
17	0.8198	0.2727
18	0.8112	0.2607
19	0.7642	0.2598
20	0.7639	0.2558
21	0.7476	0.2451
22	0.7000	0.2341
23	0.6893	0.2310
24	0.6118	0.2237
25	0.5891	0.2204

26	0.5608	0.2164
27	0.5277	0.2126
28	0.5240	0.2077
29	0.4980	0.1868
30	0.4136	0.1703
31	0.4018	0.1683
32	0.3939	0.1673
33	0.3564	0.1636
34	0.3420	0.1547
35	0.3376	0.1487
36	0.3241	0.1291
37	0.2111	0.1192
38	0.1484	0.1145
39	0.0776	0.1056
40	0.0303	0.0959
41	0.0008	0.0941
42	0.0008	0.0711
43	0.0008	0.0697

DRAFT

## Duration Flows

The Facility PASSED

Flow(cfs)	Predev	Mit	Percentage	Pass/Fail
0.1750	862	430	49	Pass
0.1925	770	313	40	Pass
0.2100	708	251	35	Pass
0.2275	653	187	28	Pass
0.2450	593	151	25	Pass
0.2625	549	116	21	Pass
0.2800	498	97	19	Pass
0.2975	462	79	17	Pass
0.3150	432	69	15	Pass
0.3325	388	56	14	Pass
0.3500	362	51	14	Pass
0.3674	340	41	12	Pass
0.3849	322	36	11	Pass
0.4024	296	27	9	Pass
0.4199	272	27	9	Pass
0.4374	250	25	10	Pass
0.4549	231	23	9	Pass
0.4724	215	23	10	Pass
0.4899	198	19	9	Pass
0.5074	185	15	8	Pass
0.5249	169	15	8	Pass
0.5424	155	14	9	Pass
0.5599	142	12	8	Pass
0.5774	136	12	8	Pass
0.5949	128	11	8	Pass
0.6124	115	10	8	Pass
0.6299	111	10	9	Pass
0.6474	102	9	8	Pass
0.6649	99	9	9	Pass
0.6824	96	9	9	Pass
0.6999	85	9	10	Pass
0.7174	77	9	11	Pass
0.7349	75	9	12	Pass
0.7523	72	9	12	Pass
0.7698	68	9	13	Pass
0.7873	61	9	14	Pass
0.8048	60	9	15	Pass
0.8223	57	9	15	Pass
0.8398	55	9	16	Pass
0.8573	52	9	17	Pass
0.8748	49	9	18	Pass
0.8923	46	9	19	Pass
0.9098	43	8	18	Pass
0.9273	39	8	20	Pass
0.9448	39	8	20	Pass
0.9623	37	7	18	Pass
0.9798	37	7	18	Pass
0.9973	31	7	22	Pass
1.0148	30	7	23	Pass
1.0323	28	7	25	Pass
1.0498	27	7	25	Pass
1.0673	27	6	22	Pass
1.0848	27	6	22	Pass

DRAFT

1.1023	24	6	25	Pass
1.1198	22	5	22	Pass
1.1372	22	5	22	Pass
1.1547	22	5	22	Pass
1.1722	21	5	23	Pass
1.1897	21	5	23	Pass
1.2072	21	5	23	Pass
1.2247	21	5	23	Pass
1.2422	21	5	23	Pass
1.2597	21	5	23	Pass
1.2772	21	5	23	Pass
1.2947	21	5	23	Pass
1.3122	21	5	23	Pass
1.3297	21	5	23	Pass
1.3472	19	5	26	Pass
1.3647	19	5	26	Pass
1.3822	18	5	27	Pass
1.3997	18	4	22	Pass
1.4172	18	4	22	Pass
1.4347	18	4	22	Pass
1.4522	18	4	22	Pass
1.4697	15	4	26	Pass
1.4872	14	4	28	Pass
1.5047	14	4	28	Pass
1.5221	14	4	28	Pass
1.5396	13	4	30	Pass
1.5571	13	4	30	Pass
1.5746	13	4	30	Pass
1.5921	13	4	30	Pass
1.6096	12	4	33	Pass
1.6271	12	4	33	Pass
1.6446	12	4	33	Pass
1.6621	12	3	25	Pass
1.6796	12	3	25	Pass
1.6971	12	3	25	Pass
1.7146	12	3	25	Pass
1.7321	12	3	25	Pass
1.7496	12	3	25	Pass
1.7671	12	3	25	Pass
1.7846	11	3	27	Pass
1.8021	11	2	18	Pass
1.8196	11	2	18	Pass
1.8371	11	2	18	Pass
1.8546	10	2	20	Pass
1.8721	10	2	20	Pass
1.8895	8	2	25	Pass
1.9070	8	2	25	Pass

DRAFT

Water Quality  
Drawdown Time Results

DRAFT

## POC 2

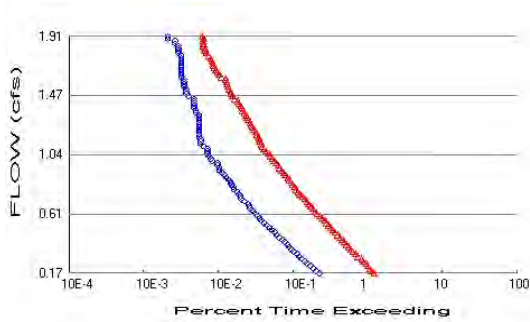

+ Pre-Project

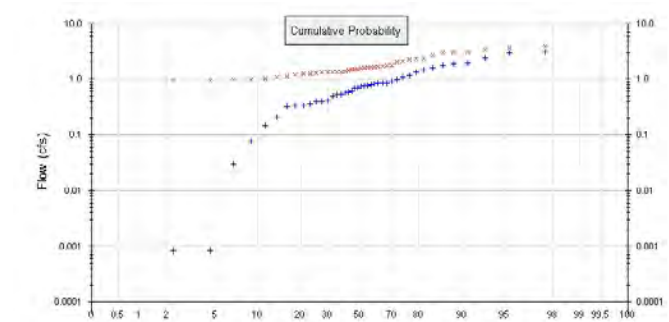

x Mitigated

### Pre-Project Landuse Totals for POC #2

Total Pervious Area: 4.34  
Total Impervious Area: 0

### Mitigated Landuse Totals for POC #2

Total Pervious Area: 0.3  
Total Impervious Area: 4.04

Flow Frequency Method: Log Pearson Type III 17B

### Flow Frequency Return Periods for Pre-Project. POC #2

Return Period	Flow(cfs)
2 year	0.699992
5 year	1.368109
10 year	1.907045
25 year	2.975886

### Flow Frequency Return Periods for Mitigated. POC #2

Return Period	Flow(cfs)
2 year	1.50648
5 year	2.312765
10 year	3.065784
25 year	3.634603

## Annual Peaks

### Annual Peaks for Pre-Project and Mitigated. POC #2

Year	Pre-Project	Mitigated
1962	0.764	1.345
1963	0.356	1.615
1964	0.078	2.319
1965	0.811	1.334
1966	0.030	1.361
1967	0.843	1.682
1968	0.211	0.944
1969	0.764	1.097
1970	0.612	1.128
1971	0.911	1.626
1972	0.001	0.964
1973	1.773	2.913
1974	0.561	1.506
1975	0.689	1.696
1976	0.001	0.827

1977	0.001	0.972
1978	0.849	2.025
1979	0.394	0.989
1980	1.343	3.042
1981	0.148	1.304
1982	1.483	2.311
1983	1.874	2.677
1984	0.700	1.360
1985	0.402	1.658
1986	2.954	3.584
1987	0.324	1.033
1988	0.589	1.219
1989	0.984	1.752
1990	0.748	1.644
1991	0.528	2.263
1992	1.101	1.506
1993	0.847	1.361
1994	0.414	1.407
1995	3.114	3.958
1996	1.935	3.346
1997	2.421	3.085
1998	1.594	2.133
1999	0.498	1.231
2000	1.165	1.763
2001	0.342	1.242
2002	0.338	1.609
2003	0.524	1.461
2004	0.820	1.439

### Ranked Annual Peaks

Ranked Annual Peaks for Pre-Project and Mitigated. POC #2

Rank	Pre-Project	Mitigated
1	3.1143	3.9578
2	2.9540	3.5836
3	2.4206	3.3456
4	1.9348	3.0854
5	1.8737	3.0423
6	1.7727	2.9133
7	1.5943	2.6767
8	1.4829	2.3186
9	1.3426	2.3115
10	1.1647	2.2631
11	1.1010	2.1330
12	0.9836	2.0253
13	0.9106	1.7631
14	0.8490	1.7520
15	0.8467	1.6961
16	0.8425	1.6819
17	0.8198	1.6584
18	0.8112	1.6443
19	0.7642	1.6256
20	0.7639	1.6151
21	0.7476	1.6087
22	0.7000	1.5065
23	0.6893	1.5055
24	0.6118	1.4611
25	0.5891	1.4393
26	0.5608	1.4073



27	0.5277	1.3613
28	0.5240	1.3606
29	0.4980	1.3605
30	0.4136	1.3449
31	0.4018	1.3344
32	0.3939	1.3040
33	0.3564	1.2419
34	0.3420	1.2305
35	0.3376	1.2185
36	0.3241	1.1281
37	0.2111	1.0966
38	0.1484	1.0330
39	0.0776	0.9890
40	0.0303	0.9716
41	0.0008	0.9635
42	0.0008	0.9440
43	0.0008	0.8269

DRAFT

## Duration Flows

Flow(cfs)	Predev	Mit	Percentage	Pass/Fail
0.1750	862	4655	540	Fail
0.1925	770	4282	556	Fail
0.2100	708	4033	569	Fail
0.2275	653	3807	583	Fail
0.2450	593	3614	609	Fail
0.2625	549	3340	608	Fail
0.2800	498	3172	636	Fail
0.2975	462	2840	614	Fail
0.3150	432	2621	606	Fail
0.3325	388	2418	623	Fail
0.3500	362	2261	624	Fail
0.3674	340	2121	623	Fail
0.3849	322	1992	618	Fail
0.4024	296	1851	625	Fail
0.4199	272	1742	640	Fail
0.4374	250	1606	642	Fail
0.4549	231	1498	648	Fail
0.4724	215	1381	642	Fail
0.4899	198	1291	652	Fail
0.5074	185	1226	662	Fail
0.5249	169	1148	679	Fail
0.5424	155	1074	692	Fail
0.5599	142	1012	712	Fail
0.5774	136	928	682	Fail
0.5949	128	862	673	Fail
0.6124	115	799	694	Fail
0.6299	111	745	671	Fail
0.6474	102	702	688	Fail
0.6649	99	662	668	Fail
0.6824	96	620	645	Fail
0.6999	85	583	685	Fail
0.7174	77	543	705	Fail
0.7349	75	507	676	Fail
0.7523	72	468	650	Fail
0.7698	68	445	654	Fail
0.7873	61	418	685	Fail
0.8048	60	394	656	Fail
0.8223	57	374	656	Fail
0.8398	55	358	650	Fail
0.8573	52	339	651	Fail
0.8748	49	326	665	Fail
0.8923	46	301	654	Fail
0.9098	43	286	665	Fail
0.9273	39	267	684	Fail
0.9448	39	252	646	Fail
0.9623	37	240	648	Fail
0.9798	37	224	605	Fail
0.9973	31	213	687	Fail
1.0148	30	201	670	Fail
1.0323	28	191	682	Fail
1.0498	27	179	662	Fail
1.0673	27	165	611	Fail
1.0848	27	154	570	Fail
1.1023	24	148	616	Fail

1.1198	22	142	645	Fail
1.1372	22	134	609	Fail
1.1547	22	134	609	Fail
1.1722	21	130	619	Fail
1.1897	21	123	585	Fail
1.2072	21	120	571	Fail
1.2247	21	114	542	Fail
1.2422	21	108	514	Fail
1.2597	21	104	495	Fail
1.2772	21	101	480	Fail
1.2947	21	96	457	Fail
1.3122	21	93	442	Fail
1.3297	21	89	423	Fail
1.3472	19	84	442	Fail
1.3647	19	80	421	Fail
1.3822	18	79	438	Fail
1.3997	18	76	422	Fail
1.4172	18	71	394	Fail
1.4347	18	69	383	Fail
1.4522	18	62	344	Fail
1.4697	15	59	393	Fail
1.4872	14	56	400	Fail
1.5047	14	56	400	Fail
1.5221	14	53	378	Fail
1.5396	13	51	392	Fail
1.5571	13	49	376	Fail
1.5746	13	49	376	Fail
1.5921	13	48	369	Fail
1.6096	12	42	350	Fail
1.6271	12	39	325	Fail
1.6446	12	37	308	Fail
1.6621	12	35	291	Fail
1.6796	12	34	283	Fail
1.6971	12	32	266	Fail
1.7146	12	32	266	Fail
1.7321	12	31	258	Fail
1.7496	12	30	250	Fail
1.7671	12	28	233	Fail
1.7846	11	26	236	Fail
1.8021	11	25	227	Fail
1.8196	11	25	227	Fail
1.8371	11	24	218	Fail
1.8546	10	24	240	Fail
1.8721	10	24	240	Fail
1.8895	8	24	300	Fail
1.9070	8	23	287	Fail

The development has an increase in flow durations for more than a 10% increase from the 2 year to the 10 year flow.

The development has an increase in flow durations for more than 10% of the flows for the range of the duration analysis.

Water Quality  
Drawdown Time Results

DRAFT

## *Model Default Modifications*

Total of 0 changes have been made.

### *PERLND Changes*

No PERLND changes have been made.

### *IMPLND Changes*

No IMPLND changes have been made.

DRAFT

*Appendix*  
*Pre-Project Schematic*



Mitigated Schematic

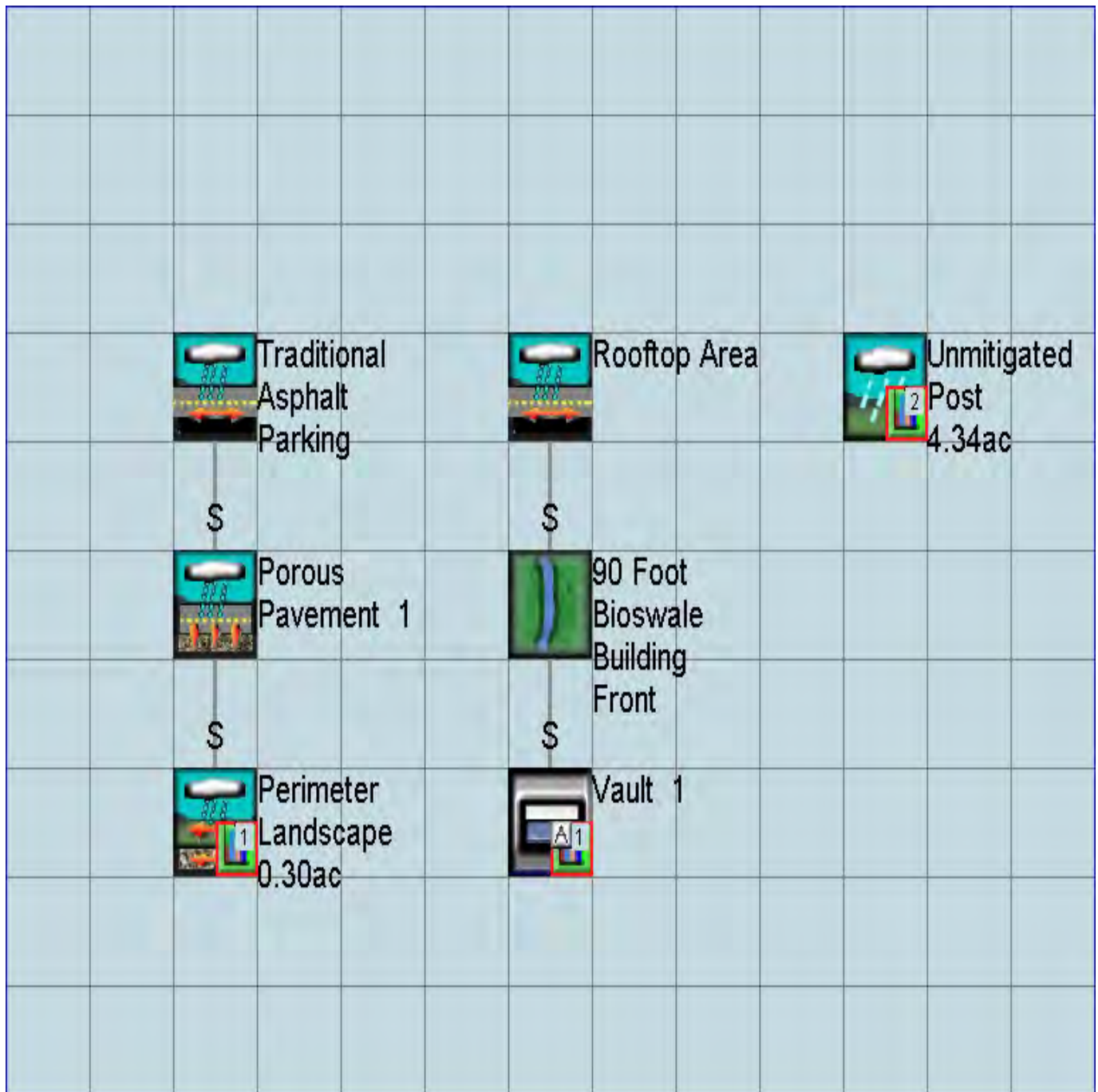

# Pre-Project UCI File

RUN

GLOBAL

WWM4 model simulation  
START 1961 10 01 END 2004 09 30  
RUN INTERP OUTPUT LEVEL 3 0  
RESUME 0 RUN 1 UNIT SYSTEM 1  
END GLOBAL

FILES

<File>	<Un#>	<-----File Name----->	***
<-ID->			***
WDM	26	Auburn Blvd Sample.wdm	
MESSU	25	PreAuburn Blvd Sample.MES	
	27	PreAuburn Blvd Sample.L61	
	28	PreAuburn Blvd Sample.L62	
	30	POCAuburn Blvd Sample1.dat	
	31	POCAuburn Blvd Sample2.dat	

END FILES

OPN SEQUENCE

INGRP INDELT 00:60  
PERLND 50  
COPY 501  
COPY 502  
DISPLY 1  
DISPLY 2

END INGRP

END OPN SEQUENCE

DISPLY

DISPLY-INFO1

#	-	#	<-----Title----->	***	TRAN	PIVL	DIG1	FIL1	PYR	DIG2	FIL2	YRND
1			Pre Development		MAX				1	2	30	9
2			Duplicate Pre Develop		MAX				1	2	31	9

END DISPLY-INFO1

END DISPLY

COPY

TIMESERIES

#	-	#	NPT	NMN	***
1			1	1	
501			1	1	
502			1	1	

END TIMESERIES

END COPY

GENER

OPCODE

#	#	OPCD	***

END OPCODE

PARM

#	#	K	***

END PARM

END GENER

PERLND

GEN-INFO

<PLS >	<-----Name----->	NBLKS	Unit-systems	Printer	***		
#	-	#	User	t-series	Engl Metr	***	
			in	out		***	
50	D,Grass,Mod (1-2%)	1	1	1	1	27	0

END GEN-INFO

\*\*\* Section PWATER\*\*\*

ACTIVITY

<PLS >	***** Active Sections *****														***
#	-	#	ATMP	SNOW	PWAT	SED	PST	PWG	PQAL	MSTL	PEST	NITR	PHOS	TRAC	***
50			0	0	1	0	0	0	0	0	0	0	0	0	

END ACTIVITY

PRINT-INFO



```

<PLS > ***** Print-flags ***** PIVL  PYR
# - # ATMP SNOW PWAT  SED  PST  PWG  PQAL MSTL PEST NITR PHOS TRAC  *****
50  - 0  0  4  0  0  0  0  0  0  0  0  0  1  9
END PRINT-INFO

```

```

PWAT-PARM1
<PLS > PWATER variable monthly parameter value flags ***
# - # CSNO RTOP UZFG  VCS  VUZ  VNN VIFW VIRG  VLE INFC  HWT ***
50  - 0  0  0  1  0  0  0  0  1  0  0
END PWAT-PARM1

```

```

PWAT-PARM2
<PLS > PWATER input info: Part 2 *****
# - # ***FOREST LZSN  INFILT  LRSUR  SLSUR  KVARY  AGWRC
50  - 0  4.35  0.028  400  0.02  3  0.92
END PWAT-PARM2

```

```

PWAT-PARM3
<PLS > PWATER input info: Part 3 *****
# - # ***PETMAX  PETMIN  INFEXP  INFILD  DEEPFR  BASETP  AGWETP
50  - 40  35  2  2  0  0  0.05
END PWAT-PARM3

```

```

PWAT-PARM4
<PLS > PWATER input info: Part 4 *****
# - # CEPSC  UZSN  NSUR  INTFW  IRC  LZETP ***
50  - 0  0.28  0.25  0.65  0.48  0
END PWAT-PARM4

```

```

MON-LZETPARM
<PLS > PWATER input info: Part 3 *****
# - # JAN FEB MAR APR MAY JUN JUL AUG SEP OCT NOV DEC ***
50  - 0.4 0.4 0.4 0.45 0.5 0.55 0.55 0.55 0.55 0.55 0.45 0.4
END MON-LZETPARM

```

```

MON-INTERCEP
<PLS > PWATER input info: Part 3 *****
# - # JAN FEB MAR APR MAY JUN JUL AUG SEP OCT NOV DEC ***
50  - 0.12 0.12 0.12 0.11 0.1 0.1 0.1 0.1 0.1 0.1 0.11 0.12
END MON-INTERCEP

```

```

PWAT-STATE1
<PLS > *** Initial conditions at start of simulation
ran from 1990 to end of 1992 (pat 1-11-95) RUN 21 ***
# - # *** CEPS  SURS  UZS  IFWS  LZS  AGWS  GWVS
50  - 0  0  0.15  0  4  0.05  0
END PWAT-STATE1

```

END PERLND

IMPLND

```

GEN-INFO
<PLS ><-----Name-----> Unit-systems Printer ***
# - # User t-series Engl Metr ***
in out ***

```

```

END GEN-INFO
*** Section IWATER***

```

```

ACTIVITY
<PLS > ***** Active Sections *****
# - # ATMP SNOW IWAT  SLD  IWG IQAL  ***
END ACTIVITY

```

```

PRINT-INFO
<ILS > ***** Print-flags ***** PIVL  PYR
# - # ATMP SNOW IWAT  SLD  IWG IQAL  *****
END PRINT-INFO

```

```

IWAT-PARM1
<PLS > IWATER variable monthly parameter value flags ***
# - # CSNO RTOP VRS  VNN RTLI  ***
END IWAT-PARM1

```

```

IWAT-PARM2
  <PLS >          IWATER input info: Part 2          ***
  # - # *** LSUR   SLSUR   NSUR   RETSC
END IWAT-PARM2

IWAT-PARM3
  <PLS >          IWATER input info: Part 3          ***
  # - # ***PETMAX  PETMIN
END IWAT-PARM3

IWAT-STATE1
  <PLS > *** Initial conditions at start of simulation
  # - # *** RETS   SURS
END IWAT-STATE1

```

END IMPLND

```

SCHEMATIC
<-Source->          <--Area-->          <-Target->  MBLK  ***
<Name> #           <-factor->          <Name> #  Tbl#  ***
Pre Development***
PERLND  50           4.34             COPY   501   12
PERLND  50           4.34             COPY   501   13
Duplicate Pre Develop***
PERLND  50           4.34             COPY   502   12
PERLND  50           4.34             COPY   502   13

*****Routing*****
END SCHEMATIC

```

```

NETWORK
<-Volume-> <-Grp> <-Member-><--Mult-->Tran <-Target vols> <-Grp> <-Member-> ***
<Name> #     <Name> # #<-factor->strg <Name> # # <Name> # # ***
COPY   501 OUTPUT MEAN  1 1  12.1     DISPLY  1   INPUT  TIMSER 1
COPY   502 OUTPUT MEAN  1 1  12.1     DISPLY  2   INPUT  TIMSER 1

<-Volume-> <-Grp> <-Member-><--Mult-->Tran <-Target vols> <-Grp> <-Member-> ***
<Name> #     <Name> # #<-factor->strg <Name> # # <Name> # # ***
END NETWORK

```

```

RCHRES
GEN-INFO
RCHRES      Name      Nexits  Unit Systems  Printer      ***
# - #<-----><----> User T-series  Engl Metr LKFG  ***
                               in out      ***

END GEN-INFO
*** Section RCHRES***

```

```

ACTIVITY
  <PLS > ***** Active Sections *****
  # - # HYFG ADFG CNFG HTFG SDFG GQFG OXFG NUGF PKFG PHFG ***
END ACTIVITY

```

```

PRINT-INFO
  <PLS > ***** Print-flags ***** PIVL  PYR
  # - # HYDR ADCA CONS HEAT  SED  GQL  OXRX NUTR PLNK PHCB PIVL  PYR  *****
END PRINT-INFO

```

```

HYDR-PARM1
RCHRES  Flags for each HYDR Section      ***
# - # VC A1 A2 A3  ODFVFG for each *** ODGTFG for each  FUNCT for each
      FG FG FG FG  possible exit *** possible exit  possible exit
      * * * * * * * * * * * * * * * * * * * * * * * * * * * * * * * * * *
END HYDR-PARM1

```

```

HYDR-PARM2
# - # FTABNO      LEN      DELTH      STCOR      KS      DB50      ***
<-----><-----><-----><-----><-----><-----><----->      ***

```

```

END HYDR-PARM2
HYDR-INIT
  RCHRES Initial conditions for each HYDR section ***
  # - # *** VOL Initial value of COLIND Initial value of OUTDGT
  *** ac-ft for each possible exit for each possible exit
<-----><-----> <-----><-----><-----><-----> *** <-----><-----><-----><-----><----->
END HYDR-INIT
END RCHRES

SPEC-ACTIONS
END SPEC-ACTIONS
FTABLES
END FTABLES

EXT SOURCES
<-Volume-> <Member> SsysSgap<--Mult-->Tran <-Target vols> <-Grp> <-Member-> ***
<Name> # <Name> # tem strg<-factor->strg <Name> # # <Name> # # ***
WDM 2 PREC ENGL 0.944 PERLND 1 999 EXTNL PREC
WDM 2 PREC ENGL 0.944 IMPLND 1 999 EXTNL PREC
WDM 1 EVAP ENGL 1 PERLND 1 999 EXTNL PETINP
WDM 1 EVAP ENGL 1 IMPLND 1 999 EXTNL PETINP

END EXT SOURCES

EXT TARGETS
<-Volume-> <-Grp> <-Member-><--Mult-->Tran <-Volume-> <Member> Tsys Tgap Amd ***
<Name> # <Name> # #<-factor->strg <Name> # <Name> tem strg strg***
COPY 501 OUTPUT MEAN 1 1 12.1 WDM 501 FLOW ENGL REPL
COPY 502 OUTPUT MEAN 1 1 12.1 WDM 502 FLOW ENGL REPL
END EXT TARGETS

MASS-LINK
<Volume> <-Grp> <-Member-><--Mult--> <Target> <-Grp> <-Member->***
<Name> <Name> # #<-factor-> <Name> <Name> # #***
MASS-LINK 12
PERLND PWATER SURO 0.083333 COPY INPUT MEAN
END MASS-LINK 12

MASS-LINK 13
PERLND PWATER IFWO 0.083333 COPY INPUT MEAN
END MASS-LINK 13

END MASS-LINK

END RUN

```

# Mitigated UCI File

RUN

GLOBAL

WVHM4 model simulation  
START 1961 10 01 END 2004 09 30  
RUN INTERP OUTPUT LEVEL 3 0  
RESUME 0 RUN 1 UNIT SYSTEM 1  
END GLOBAL

FILES

<File>	<Un#>	<-----File Name----->	***
<-ID->			***
WDM	26	Auburn Blvd Sample.wdm	
MESSU	25	MitAuburn Blvd Sample.MES	
	27	MitAuburn Blvd Sample.L61	
	28	MitAuburn Blvd Sample.L62	
	30	POCAuburn Blvd Sample1.dat	
	31	POCAuburn Blvd Sample2.dat	

END FILES

OPN SEQUENCE

INGRP INDELT 00:60  
IMPLND 6  
PERLND 50  
IMPLND 2  
IMPLND 9  
IMPLND 8  
RCHRES 1  
RCHRES 2  
PERLND 66  
RCHRES 3  
COPY 502  
COPY 501  
COPY 1  
DISPLY 2  
DISPLY 1

END INGRP

END OPN SEQUENCE

DISPLY

DISPLY-INFO1

#	-	#	<-----Title----->	***	TRAN	PIVL	DIG1	FIL1	PYR	DIG2	FIL2	YRND
2			Unmitigated Post		MAX				1	2	31	9
1			Perimeter Landscape		MAX				1	2	30	9

END DISPLY-INFO1

END DISPLY

COPY

TIMESERIES

#	-	#	NPT	NMN	***
1			1	1	
502			1	1	
501			1	1	

END TIMESERIES

END COPY

GENER

OPCODE

# # OPCD \*\*\*

END OPCODE

PARM

# # K \*\*\*

END PARM

END GENER

PERLND

GEN-INFO

<PLS >	<-----Name----->	NBLKS	Unit-systems	Printer	***		
#	-	#	User	t-series	Engl Metr	***	
			in	out		***	
50	D,Grass,Mod (1-2%)	1	1	1	1	27	0
66	D,Grass,Mod (1-2%)	1	1	1	1	27	0

END GEN-INFO  
\*\*\* Section PWATER\*\*\*

ACTIVITY  
<PLS > \*\*\*\*\* Active Sections \*\*\*\*\*  
# - # ATMP SNOW PWAT SED PST PWG PQAL MSTL PEST NITR PHOS TRAC \*\*\*  
50 0 0 1 0 0 0 0 0 0 0 0 0  
66 0 0 1 0 0 0 0 0 0 0 0 0  
END ACTIVITY

PRINT-INFO  
<PLS > \*\*\*\*\* Print-flags \*\*\*\*\* PIVL PYR  
# - # ATMP SNOW PWAT SED PST PWG PQAL MSTL PEST NITR PHOS TRAC \*\*\*\*\*  
50 0 0 4 0 0 0 0 0 0 0 0 0 1 9  
66 0 0 4 0 0 0 0 0 0 0 0 0 0 1 9  
END PRINT-INFO

PWAT-PARM1  
<PLS > PWATER variable monthly parameter value flags \*\*\*  
# - # CSNO RTOP UZFG VCS VUZ VNN VIFW VIRG VLE INFC HWT \*\*\*  
50 0 0 0 1 0 0 0 0 1 0 0  
66 0 0 0 1 0 0 0 0 1 0 0  
END PWAT-PARM1

PWAT-PARM2  
<PLS > PWATER input info: Part 2 \*\*\*  
# - # \*\*\*FOREST LZSN INFILF LSUR SLSUR KVARY AGWRC  
50 0 4.35 0.028 400 0.02 3 0.92  
66 0 4.35 0.028 400 0.02 3 0.92  
END PWAT-PARM2

PWAT-PARM3  
<PLS > PWATER input info: Part 3 \*\*\*  
# - # \*\*\*PETMAX PETMIN INFEXP INFILD DEEPFR BASETP AGWETP  
50 40 35 2 2 0 0 0.05  
66 40 35 2 2 0 0 0.05  
END PWAT-PARM3

PWAT-PARM4  
<PLS > PWATER input info: Part 4 \*\*\*  
# - # CEPSC UZSN NSUR INTFW IRC LZETP \*\*\*  
50 0 0.28 0.25 0.65 0.48 0  
66 0 0.28 0.25 0.65 0.48 0  
END PWAT-PARM4

MON-LZETPARM  
<PLS > PWATER input info: Part 3 \*\*\*  
# - # JAN FEB MAR APR MAY JUN JUL AUG SEP OCT NOV DEC \*\*\*  
50 0.4 0.4 0.4 0.45 0.5 0.55 0.55 0.55 0.55 0.55 0.45 0.4  
66 0.4 0.4 0.4 0.45 0.5 0.55 0.55 0.55 0.55 0.55 0.45 0.4  
END MON-LZETPARM

MON-INTERCEP  
<PLS > PWATER input info: Part 3 \*\*\*  
# - # JAN FEB MAR APR MAY JUN JUL AUG SEP OCT NOV DEC \*\*\*  
50 0.12 0.12 0.12 0.11 0.1 0.1 0.1 0.1 0.1 0.1 0.11 0.12  
66 0.12 0.12 0.12 0.11 0.1 0.1 0.1 0.1 0.1 0.1 0.11 0.12  
END MON-INTERCEP

PWAT-STATE1  
<PLS > \*\*\* Initial conditions at start of simulation  
ran from 1990 to end of 1992 (pat 1-11-95) RUN 21 \*\*\*  
# - # \*\*\* CEPS SURS UZS IFWS LZS AGWS GWVS  
50 0 0 0.15 0 4 0.05 0  
66 0 0 0.15 0 4 0.05 0  
END PWAT-STATE1

END PERLND

IMPLND

GEN-INFO  
<PLS ><-----Name-----> Unit-systems Printer \*\*\*  
# - # User t-series Engl Metr \*\*\*

```

                in   out           ***
6      Imperv,Flat(0-1%) LAT   1   1   1   27   0
2      Imperv,Mod (1-2%)      1   1   1   27   0
9      Imperv,Flat(0-1%) LAT   1   1   1   27   0
8      Porous Pavement        1   1   1   27   0
END GEN-INFO
*** Section IWATER***

```

```

ACTIVITY
<PLS > ***** Active Sections *****
# - # ATMP SNOW IWAT  SLD  IWG IQAL  ***
6      0    0    1    0    0    0
2      0    0    1    0    0    0
9      0    0    1    0    0    0
8      0    0    1    0    0    0
END ACTIVITY

```

```

PRINT-INFO
<ILS > ***** Print-flags ***** PIVL  PYR
# - # ATMP SNOW IWAT  SLD  IWG IQAL  *****
6      0    0    4    0    0    0    1    9
2      0    0    4    0    0    0    1    9
9      0    0    4    0    0    0    1    9
8      0    0    4    0    0    0    1    9
END PRINT-INFO

```

```

IWAT-PARM1
<PLS > IWATER variable monthly parameter value flags ***
# - # CSNO RTOP  VRS  VNN RTLI  ***
6      0    0    0    0    0
2      0    0    0    0    0
9      0    0    0    0    0
8      0    0    0    0    0
END IWAT-PARM1

```

```

IWAT-PARM2
<PLS > IWATER input info: Part 2           ***
# - # ***  LSUR  SLSUR  NSUR  RETSC
6      100    0.01  0.05  0.1
2      100    0.02  0.05  0.1
9      100    0.01  0.05  0.1
8      100    0.01  0.05  0.1
END IWAT-PARM2

```

```

IWAT-PARM3
<PLS > IWATER input info: Part 3           ***
# - # ***PETMAX  PETMIN
6      0          0
2      0          0
9      0          0
8      0          0
END IWAT-PARM3

```

```

IWAT-STATE1
<PLS > *** Initial conditions at start of simulation
# - # ***  RETS  SURS
6      0          0
2      0          0
9      0          0
8      0          0
END IWAT-STATE1

```

END IMPLND

```

SCHEMATIC
<-Source->          <--Area-->          <-Target->          MBLK          ***
<Name> #            <-factor->          <Name> #          Tbl#          ***
Traditional Asphalt Parking***
IMPLND 6            3.5008          IMPLND 8          53
IMPLND 8            0.7998          RCHRES 1          5

```

```

Rooftop Area***
IMPLND 9 0.44 RCHRES 2 5
Perimeter Landscape***
PERLND 66 0.3 COPY 501 12
PERLND 66 0.3 COPY 501 13
Unmitigated Post***
PERLND 50 0.3 COPY 502 12
PERLND 50 0.3 COPY 502 13
IMPLND 2 4.04 COPY 502 15

```

```

*****Routing*****
RCHRES 1 3.3333 PERLND 66 63
RCHRES 1 3.3333 COPY 1 73
RCHRES 2 1 RCHRES 3 6
RCHRES 2 COPY 1 16
RCHRES 3 1 COPY 501 16
END SCHEMATIC

```

```

NETWORK
<-Volume-> <-Grp> <-Member-><--Mult-->Tran <-Target vols> <-Grp> <-Member-> ***
<Name> # <Name> # #<-factor->strg <Name> # # <Name> # # ***
COPY 502 OUTPUT MEAN 1 1 12.1 DISPLY 2 INPUT TIMSER 1
COPY 501 OUTPUT MEAN 1 1 12.1 DISPLY 1 INPUT TIMSER 1

```

```

<-Volume-> <-Grp> <-Member-><--Mult-->Tran <-Target vols> <-Grp> <-Member-> ***
<Name> # <Name> # #<-factor->strg <Name> # # <Name> # # ***
END NETWORK

```

```

RCHRES
GEN-INFO
RCHRES Name Nexits Unit Systems Printer ***
# - #<-----><--> User T-series Engl Metr LKFG ***
in out ***
1 Porous Pavement -009 2 1 1 1 28 0 1
2 90 Foot Bioswale-013 1 1 1 1 28 0 1
3 Vault 1 1 1 1 28 0 1
END GEN-INFO
*** Section RCHRES***

```

```

ACTIVITY
<PLS > ***** Active Sections *****
# - # HYFG ADFG CNFG HTFG SDFG GQFG OXFG NUFG PKFG PHFG ***
1 1 0 0 0 0 0 0 0 0 0 0
2 1 0 0 0 0 0 0 0 0 0 0
3 1 0 0 0 0 0 0 0 0 0 0
END ACTIVITY

```

```

PRINT-INFO
<PLS > ***** Print-flags ***** PIVL PYR
# - # HYDR ADCA CONS HEAT SED GQL OXRX NUTR PLNK PHCB PIVL PYR *****
1 4 0 0 0 0 0 0 0 0 0 0 1 9
2 4 0 0 0 0 0 0 0 0 0 0 1 9
3 4 0 0 0 0 0 0 0 0 0 0 1 9
END PRINT-INFO

```

```

HYDR-PARM1
RCHRES Flags for each HYDR Section ***
# - # VC A1 A2 A3 ODFVFG for each *** ODGTFG for each FUNCT for each
FG FG FG FG possible exit *** possible exit possible exit
* * * * * * * * * * * * * * * * * * * * * * * * * * * * * * * * * * * * * * * * *
1 0 1 0 0 4 5 0 0 0 0 0 0 0 0 0 2 2 2 2 2
2 0 1 0 0 4 0 0 0 0 0 0 0 0 0 0 2 2 2 2 2
3 0 1 0 0 4 0 0 0 0 0 0 0 0 0 0 2 2 2 2 2
END HYDR-PARM1

```

```

HYDR-PARM2
# - # FTABNO LEN DELTH STCOR KS DB50 ***
<-----><-----><-----><-----><-----><-----><-----> ***

```

1	1	0.33	0.0	0.0	0.5	0.0
2	2	0.02	0.0	0.0	0.5	0.0
3	3	0.01	0.0	0.0	0.5	0.0

END HYDR-PARM2

HYDR-INIT

RCHRES Initial conditions for each HYDR section \*\*\*

#	#	VOL	Initial value of COLIND					Initial value of OUTDGT				
*** ac-ft		for each possible exit					for each possible exit					
<-----><----->		<--><--><--><--><-->	*** <--><--><--><--><-->									
1	0	4.0	5.0	0.0	0.0	0.0	0.0	0.0	0.0	0.0	0.0	
2	0	4.0	0.0	0.0	0.0	0.0	0.0	0.0	0.0	0.0	0.0	
3	0	4.0	0.0	0.0	0.0	0.0	0.0	0.0	0.0	0.0	0.0	

END HYDR-INIT

END RCHRES

SPEC-ACTIONS

END SPEC-ACTIONS

FTABLES

FTABLE 1  
92 5

Depth (ft)	Area (acres)	Volume (acre-ft)	Outflow1 (cfs)	Outflow2 (cfs)	Velocity (ft/sec)	Travel Time*** (Minutes)***
0.000000	0.799816	0.000000	0.000000	0.000000		
0.027473	0.800915	0.008795	0.000000	0.056454		
0.054945	0.802014	0.017603	0.000000	0.056454		
0.082418	0.803112	0.026422	0.000000	0.056454		
0.109890	0.804211	0.035253	0.000000	0.056454		
0.137363	0.805310	0.044097	0.000000	0.056454		
0.164835	0.806408	0.052952	0.000000	0.056454		
0.192308	0.807507	0.061820	0.000000	0.056454		
0.219780	0.808606	0.070700	0.000000	0.056454		
0.247253	0.809704	0.079592	0.000000	0.056454		
0.274725	0.810803	0.088496	0.000000	0.056454		
0.302198	0.811901	0.097412	0.000000	0.056454		
0.329670	0.813000	0.106340	0.000000	0.056454		
0.357143	0.814099	0.115280	0.000000	0.056454		
0.384615	0.815197	0.124232	0.000000	0.056454		
0.412088	0.816296	0.133196	0.000000	0.056454		
0.439560	0.817395	0.142172	0.000000	0.056454		
0.467033	0.818493	0.151161	0.000000	0.056454		
0.494505	0.819592	0.160161	0.000000	0.056454		
0.521978	0.820691	0.169174	0.000000	0.056454		
0.549451	0.821789	0.178198	0.000000	0.056454		
0.576923	0.822888	0.187235	0.000000	0.056454		
0.604396	0.823987	0.196284	0.000000	0.056454		
0.631868	0.825085	0.205345	0.000000	0.056454		
0.659341	0.826184	0.214418	0.000000	0.056454		
0.686813	0.827283	0.223503	0.000000	0.056454		
0.714286	0.828381	0.232600	0.000000	0.056454		
0.741758	0.829480	0.241709	0.000000	0.056454		
0.769231	0.830579	0.250830	0.000000	0.056454		
0.796703	0.831677	0.259963	0.000000	0.056454		
0.824176	0.832776	0.269109	0.000000	0.056454		
0.851648	0.833874	0.278266	0.000000	0.056454		
0.879121	0.834973	0.287436	0.000000	0.056454		
0.906593	0.836072	0.296617	0.000000	0.056454		
0.934066	0.837170	0.305811	0.000000	0.056454		
0.961538	0.838269	0.315016	0.000000	0.056454		
0.989011	0.839368	0.324234	0.000000	0.056454		
1.016484	0.840466	0.333464	0.030348	0.056454		
1.043956	0.841565	0.342706	0.049558	0.056454		
1.071429	0.842664	0.351960	0.063174	0.056454		
1.098901	0.843762	0.361226	0.074336	0.056454		
1.126374	0.844861	0.370504	0.084029	0.056454		
1.153846	0.845960	0.379794	0.092714	0.056454		
1.181319	0.847058	0.389097	0.100652	0.056454		
1.208791	0.848157	0.398411	0.108008	0.056454		
1.236264	0.849256	0.407738	0.114895	0.056454		
1.263736	0.850354	0.417076	0.121391	0.056454		
1.291209	0.851453	0.426427	0.127557	0.056454		



1.318681	0.852551	0.435789	0.133438	0.056454
1.346154	0.853650	0.445164	0.139071	0.056454
1.373626	0.854749	0.454551	0.144484	0.056454
1.401099	0.855847	0.463950	0.149702	0.056454
1.428571	0.856946	0.473361	0.154744	0.056454
1.456044	0.858045	0.482784	0.159626	0.056454
1.483516	0.859143	0.492219	0.164364	0.056454
1.510989	0.860242	0.501666	0.168969	0.056454
1.538462	0.861341	0.511125	0.173452	0.056454
1.565934	0.862439	0.520597	0.177822	0.056454
1.593407	0.863538	0.530080	0.182086	0.056454
1.620879	0.864637	0.539575	0.186254	0.056454
1.648352	0.865735	0.549083	0.190330	0.056454
1.675824	0.866834	0.558603	0.194320	0.056454
1.703297	0.867933	0.568134	0.198231	0.056454
1.730769	0.869031	0.577678	0.202065	0.056454
1.758242	0.870130	0.587234	0.205828	0.056454
1.785714	0.871229	0.596802	0.209524	0.056454
1.813187	0.872327	0.606382	0.213156	0.056454
1.840659	0.873426	0.615974	0.216726	0.056454
1.868132	0.874524	0.625578	0.220239	0.056454
1.895604	0.875623	0.635194	0.223697	0.056454
1.923077	0.876722	0.644822	0.227102	0.056454
1.950549	0.877820	0.654463	0.230456	0.056454
1.978022	0.878919	0.664115	0.233763	0.056454
2.005495	0.880018	0.688276	0.243805	0.056454
2.032967	0.881116	0.712468	0.339903	0.056454
2.060440	0.882215	0.736689	0.490811	0.056454
2.087912	0.883314	0.760941	0.680544	0.056454
2.115385	0.884412	0.785223	0.902223	0.056454
2.142857	0.885511	0.809535	1.151711	0.056454
2.170330	0.886610	0.833877	1.426156	0.056454
2.197802	0.887708	0.858250	1.723440	0.056454
2.225275	0.888807	0.882653	2.041906	0.056454
2.252747	0.889906	0.907086	2.380216	0.056454
2.280220	0.891004	0.931549	2.737254	0.056454
2.307692	0.892103	0.956042	3.112077	0.056454
2.335165	0.893201	0.980565	3.503869	0.056454
2.362637	0.894300	1.005119	3.911919	0.056454
2.390110	0.895399	1.029703	4.335597	0.056454
2.417582	0.896497	1.054317	4.774342	0.056454
2.445055	0.897596	1.078961	5.227649	0.056454
2.472527	0.898695	1.103635	5.695062	0.056454
2.500000	0.899793	1.128340	6.176163	0.056454

END FTABLE 1  
 FTABLE 2  
 91 4

Depth (ft)	Area (acres)	Volume (acre-ft)	Outflowl (cfs)	Velocity (ft/sec)	Travel Time*** (Minutes)***
0.000000	0.004132	0.000000	0.000000		
0.005556	0.004201	0.000023	0.000520		
0.011111	0.004270	0.000047	0.001656		
0.016667	0.004339	0.000071	0.003263		
0.022222	0.004408	0.000095	0.005284		
0.027778	0.004477	0.000120	0.007683		
0.033333	0.004545	0.000145	0.010439		
0.038889	0.004614	0.000170	0.013533		
0.044444	0.004683	0.000196	0.016952		
0.050000	0.004752	0.000222	0.020686		
0.055556	0.004821	0.000249	0.024727		
0.061111	0.004890	0.000276	0.029068		
0.066667	0.004959	0.000303	0.033703		
0.072222	0.005028	0.000331	0.038627		
0.077778	0.005097	0.000359	0.043838		
0.083333	0.005165	0.000387	0.049330		
0.088889	0.005234	0.000416	0.055103		
0.094444	0.005303	0.000446	0.061152		
0.100000	0.005372	0.000475	0.067477		
0.105556	0.005441	0.000505	0.074077		
0.111111	0.005510	0.000536	0.080948		

0.116667	0.005579	0.000566	0.088092
0.122222	0.005648	0.000598	0.095506
0.127778	0.005716	0.000629	0.103191
0.133333	0.005785	0.000661	0.111145
0.138889	0.005854	0.000693	0.119369
0.144444	0.005923	0.000726	0.127862
0.150000	0.005992	0.000759	0.136625
0.155556	0.006061	0.000793	0.145657
0.161111	0.006130	0.000827	0.154959
0.166667	0.006199	0.000861	0.164530
0.172222	0.006267	0.000896	0.174372
0.177778	0.006336	0.000931	0.184485
0.183333	0.006405	0.000966	0.194869
0.188889	0.006474	0.001002	0.205525
0.194444	0.006543	0.001038	0.216454
0.200000	0.006612	0.001074	0.227655
0.205556	0.006681	0.001111	0.239131
0.211111	0.006750	0.001149	0.250881
0.216667	0.006819	0.001186	0.262907
0.222222	0.006887	0.001224	0.275209
0.227778	0.006956	0.001263	0.287789
0.233333	0.007025	0.001302	0.300647
0.238889	0.007094	0.001341	0.313784
0.244444	0.007163	0.001381	0.327201
0.250000	0.007232	0.001420	0.340900
0.255556	0.007301	0.001461	0.354881
0.261111	0.007370	0.001502	0.369145
0.266667	0.007438	0.001543	0.383693
0.272222	0.007507	0.001584	0.398527
0.277778	0.007576	0.001626	0.413648
0.283333	0.007645	0.001668	0.429057
0.288889	0.007714	0.001711	0.444754
0.294444	0.007783	0.001754	0.460742
0.300000	0.007852	0.001798	0.477021
0.305556	0.007921	0.001841	0.493592
0.311111	0.007990	0.001886	0.510458
0.316667	0.008058	0.001930	0.527618
0.322222	0.008127	0.001975	0.545074
0.327778	0.008196	0.002020	0.562828
0.333333	0.008265	0.002066	0.580880
0.338889	0.008334	0.002112	0.599232
0.344444	0.008403	0.002159	0.617885
0.350000	0.008472	0.002206	0.636841
0.355556	0.008541	0.002253	0.656100
0.361111	0.008610	0.002301	0.675665
0.366667	0.008678	0.002349	0.695535
0.372222	0.008747	0.002397	0.715713
0.377778	0.008816	0.002446	0.736200
0.383333	0.008885	0.002495	0.756997
0.388889	0.008954	0.002545	0.778106
0.394444	0.009023	0.002594	0.799527
0.400000	0.009092	0.002645	0.821263
0.405556	0.009161	0.002695	0.843314
0.411111	0.009229	0.002747	0.865681
0.416667	0.009298	0.002798	0.888367
0.422222	0.009367	0.002850	0.911371
0.427778	0.009436	0.002902	0.934697
0.433333	0.009505	0.002955	0.958344
0.438889	0.009574	0.003008	0.982315
0.444444	0.009643	0.003061	1.006611
0.450000	0.009712	0.003115	1.031232
0.455556	0.009781	0.003169	1.056181
0.461111	0.009849	0.003224	1.081459
0.466667	0.009918	0.003278	1.107066
0.472222	0.009987	0.003334	1.133005
0.477778	0.010056	0.003389	1.159277
0.483333	0.010125	0.003445	1.185882
0.488889	0.010194	0.003502	1.212823
0.494444	0.010263	0.003559	1.240101
0.500000	0.010332	0.003616	1.267716

END FTABLE 2

FTABLE 3

92 4

Depth (ft)	Area (acres)	Volume (acre-ft)	Outflow1 (cfs)	Velocity (ft/sec)	Travel Time*** (Minutes)***
0.000000	0.005165	0.000000	0.000000		
0.033333	0.005165	0.000172	0.043156		
0.066667	0.005165	0.000344	0.061032		
0.100000	0.005165	0.000517	0.074748		
0.133333	0.005165	0.000689	0.086312		
0.166667	0.005165	0.000861	0.096500		
0.200000	0.005165	0.001033	0.105710		
0.233333	0.005165	0.001205	0.114180		
0.266667	0.005165	0.001377	0.122064		
0.300000	0.005165	0.001550	0.129468		
0.333333	0.005165	0.001722	0.136471		
0.366667	0.005165	0.001894	0.143132		
0.400000	0.005165	0.002066	0.149497		
0.433333	0.005165	0.002238	0.155601		
0.466667	0.005165	0.002410	0.161475		
0.500000	0.005165	0.002583	0.167142		
0.533333	0.005165	0.002755	0.172624		
0.566667	0.005165	0.002927	0.177937		
0.600000	0.005165	0.003099	0.183095		
0.633333	0.005165	0.003271	0.188113		
0.666667	0.005165	0.003444	0.192999		
0.700000	0.005165	0.003616	0.197766		
0.733333	0.005165	0.003788	0.202419		
0.766667	0.005165	0.003960	0.206969		
0.800000	0.005165	0.004132	0.211420		
0.833333	0.005165	0.004304	0.215780		
0.866667	0.005165	0.004477	0.220053		
0.900000	0.005165	0.004649	0.224245		
0.933333	0.005165	0.004821	0.228360		
0.966667	0.005165	0.004993	0.232402		
1.000000	0.005165	0.005165	0.236375		
1.033333	0.005165	0.005337	0.240282		
1.066667	0.005165	0.005510	0.244127		
1.100000	0.005165	0.005682	0.247912		
1.133333	0.005165	0.005854	0.251640		
1.166667	0.005165	0.006026	0.255314		
1.200000	0.005165	0.006198	0.258936		
1.233333	0.005165	0.006371	0.262508		
1.266667	0.005165	0.006543	0.266031		
1.300000	0.005165	0.006715	0.269509		
1.333333	0.005165	0.006887	0.272942		
1.366667	0.005165	0.007059	0.276333		
1.400000	0.005165	0.007231	0.279683		
1.433333	0.005165	0.007404	0.282993		
1.466667	0.005165	0.007576	0.286264		
1.500000	0.005165	0.007748	0.289499		
1.533333	0.005165	0.007920	0.292698		
1.566667	0.005165	0.008092	0.295862		
1.600000	0.005165	0.008264	0.298993		
1.633333	0.005165	0.008437	0.302092		
1.666667	0.005165	0.008609	0.305159		
1.700000	0.005165	0.008781	0.308195		
1.733333	0.005165	0.008953	0.311202		
1.766667	0.005165	0.009125	0.314180		
1.800000	0.005165	0.009298	0.317130		
1.833333	0.005165	0.009470	0.320053		
1.866667	0.005165	0.009642	0.322950		
1.900000	0.005165	0.009814	0.325820		
1.933333	0.005165	0.009986	0.328666		
1.966667	0.005165	0.010158	0.331487		
2.000000	0.005165	0.010331	0.334285		
2.033333	0.005165	0.010503	0.337059		
2.066667	0.005165	0.010675	0.339810		
2.100000	0.005165	0.010847	0.342540		
2.133333	0.005165	0.011019	0.345248		

2.166667	0.005165	0.011191	0.347935
2.200000	0.005165	0.011364	0.350601
2.233333	0.005165	0.011536	0.353247
2.266667	0.005165	0.011708	0.355873
2.300000	0.005165	0.011880	0.358480
2.333333	0.005165	0.012052	0.361069
2.366667	0.005165	0.012225	0.363639
2.400000	0.005165	0.012397	0.366191
2.433333	0.005165	0.012569	0.368725
2.466667	0.005165	0.012741	0.371242
2.500000	0.005165	0.012913	0.373742
2.533333	0.005165	0.013085	0.376225
2.566667	0.005165	0.013258	0.378692
2.600000	0.005165	0.013430	0.381143
2.633333	0.005165	0.013602	0.383579
2.666667	0.005165	0.013774	0.385999
2.700000	0.005165	0.013946	0.388404
2.733333	0.005165	0.014118	0.390794
2.766667	0.005165	0.014291	0.393170
2.800000	0.005165	0.014463	0.395531
2.833333	0.005165	0.014635	0.397878
2.866667	0.005165	0.014807	0.400212
2.900000	0.005165	0.014979	0.402532
2.933333	0.005165	0.015152	0.404839
2.966667	0.005165	0.015324	0.407133
3.000000	0.005165	0.015496	0.409414
3.033333	0.005165	0.015668	0.411682

END FTABLE 3

END FTABLES

EXT SOURCES

<-Volume->	<Member>	SsysSgap	<--Mult-->	Tran	<-Target vols>	<-Grp>	<-Member->	***	
<Name>	#	<Name>	#	tem strg	<-factor-->	strg	<Name>	# #	***
WDM	2	PREC	ENGL	0.944	PERLND	1 999	EXTNL	PREC	
WDM	2	PREC	ENGL	0.944	IMPLND	1 999	EXTNL	PREC	
WDM	1	EVAP	ENGL	1	PERLND	1 999	EXTNL	PETINP	
WDM	1	EVAP	ENGL	1	IMPLND	1 999	EXTNL	PETINP	
WDM	1	EVAP	ENGL	1	RCHRES	1	EXTNL	POTEV	

END EXT SOURCES

EXT TARGETS

<-Volume->	<-Grp>	<-Member->	<--Mult-->	Tran	<-Volume->	<Member>	Tsys	Tgap	Amd	***	
<Name>	#	<Name>	#	#	<-factor-->	strg	<Name>	tem	strg	strg	***
COPY	1	OUTPUT	MEAN	1 1	12.1	WDM	701	FLOW	ENGL	REPL	
COPY	501	OUTPUT	MEAN	1 1	12.1	WDM	801	FLOW	ENGL	REPL	
COPY	2	OUTPUT	MEAN	1 1	12.1	WDM	702	FLOW	ENGL	REPL	
COPY	502	OUTPUT	MEAN	1 1	12.1	WDM	802	FLOW	ENGL	REPL	
RCHRES	3	HYDR	RO	1 1	1	WDM	1000	FLOW	ENGL	REPL	
RCHRES	3	HYDR	STAGE	1 1	1	WDM	1001	STAG	ENGL	REPL	

END EXT TARGETS

MASS-LINK

<Volume>	<-Grp>	<-Member->	<--Mult-->	<Target>	<-Grp>	<-Member->	***	
<Name>	#	<Name>	#	<-factor-->	<Name>	#	#	***
MASS-LINK			5					
IMPLND	IWATER	SURO		0.083333	RCHRES	INFLOW	IVOL	
END MASS-LINK			5					
MASS-LINK			6					
RCHRES	ROFLOW				RCHRES	INFLOW		
END MASS-LINK			6					
MASS-LINK			12					
PERLND	PWATER	SURO		0.083333	COPY	INPUT	MEAN	
END MASS-LINK			12					
MASS-LINK			13					
PERLND	PWATER	IFWO		0.083333	COPY	INPUT	MEAN	
END MASS-LINK			13					

MASS-LINK	15						
IMPLND	IWATER	SURO		0.083333	COPY	INPUT	MEAN
END MASS-LINK	15						
MASS-LINK	16						
RCHRES	ROFLOW				COPY	INPUT	MEAN
END MASS-LINK	16						
MASS-LINK	53						
IMPLND	IWATER	SURO			IMPLND	EXTNL	SURLI
END MASS-LINK	53						
MASS-LINK	63						
RCHRES	OFLOW	OVOL	1	12.00000	PERLND	EXTNL	SURLI
END MASS-LINK	63						
MASS-LINK	73						
RCHRES	OFLOW	OVOL	1		COPY	INPUT	MEAN
END MASS-LINK	73						

END MASS-LINK

END RUN

DRAFT

DRAFT

DRAFT

## *Disclaimer*

### *Legal Notice*

This program and accompanying documentation are provided 'as-is' without warranty of any kind. The entire risk regarding the performance and results of this program is assumed by End User. Clear Creek Solutions Inc. and the governmental licensee or sublicensees disclaim all warranties, either expressed or implied, including but not limited to implied warranties of program and accompanying documentation. In no event shall Clear Creek Solutions Inc. be liable for any damages whatsoever (including without limitation to damages for loss of business profits, loss of business information, business interruption, and the like) arising out of the use of, or inability to use this program even if Clear Creek Solutions Inc. or their authorized representatives have been advised of the possibility of such damages. Software Copyright © by : Clear Creek Solutions, Inc. 2005-2013; All Rights Reserved.

Clear Creek Solutions, Inc.  
6200 Capitol Blvd. Ste F  
Olympia, WA. 98501  
Toll Free 1(866)943-0304  
Local (360)943-0304

[www.clearcreeksolutions.com](http://www.clearcreeksolutions.com)

DRAFT



**LID Points Tabulation**

LID Measures	Pre Time Series	Pre Volume (ac-ft)	Post Unmit. Element Name	Post Unmit. Time Series	Post Unmit. Volume (ac-ft)	Post Mitigated Element Name	Post Mitigated Time Series	Post Mit. Volume (ac-ft)	LID Pts
Porous Pavement, 90 Foot Bioswale Building Front	501	49	Unmitigated Post	802	215.3	Porous Pavement 1, 90 Foot Bioswale Building Front	801	42.7	207.58
								<b>Total</b>	<b>207.58</b>

# Channel Report

## 90 Foot Swale at Building Front

### Trapezoidal

Bottom Width (ft) = 2.00  
Side Slopes (z:1) = 3.00, 3.00  
Total Depth (ft) = 0.50  
Invert Elev (ft) = 100.00  
Slope (%) = 1.00  
N-Value = 0.200

### Highlighted

Depth (ft) = 0.17  
Q (cfs) = 0.080  
Area (sqft) = 0.43  
Velocity (ft/s) = 0.19  
Wetted Perim (ft) = 3.08  
Crit Depth, Yc (ft) = 0.04  
Top Width (ft) = 3.02  
EGL (ft) = 0.17

### Calculations

Compute by: Known Q  
Known Q (cfs) = 0.08

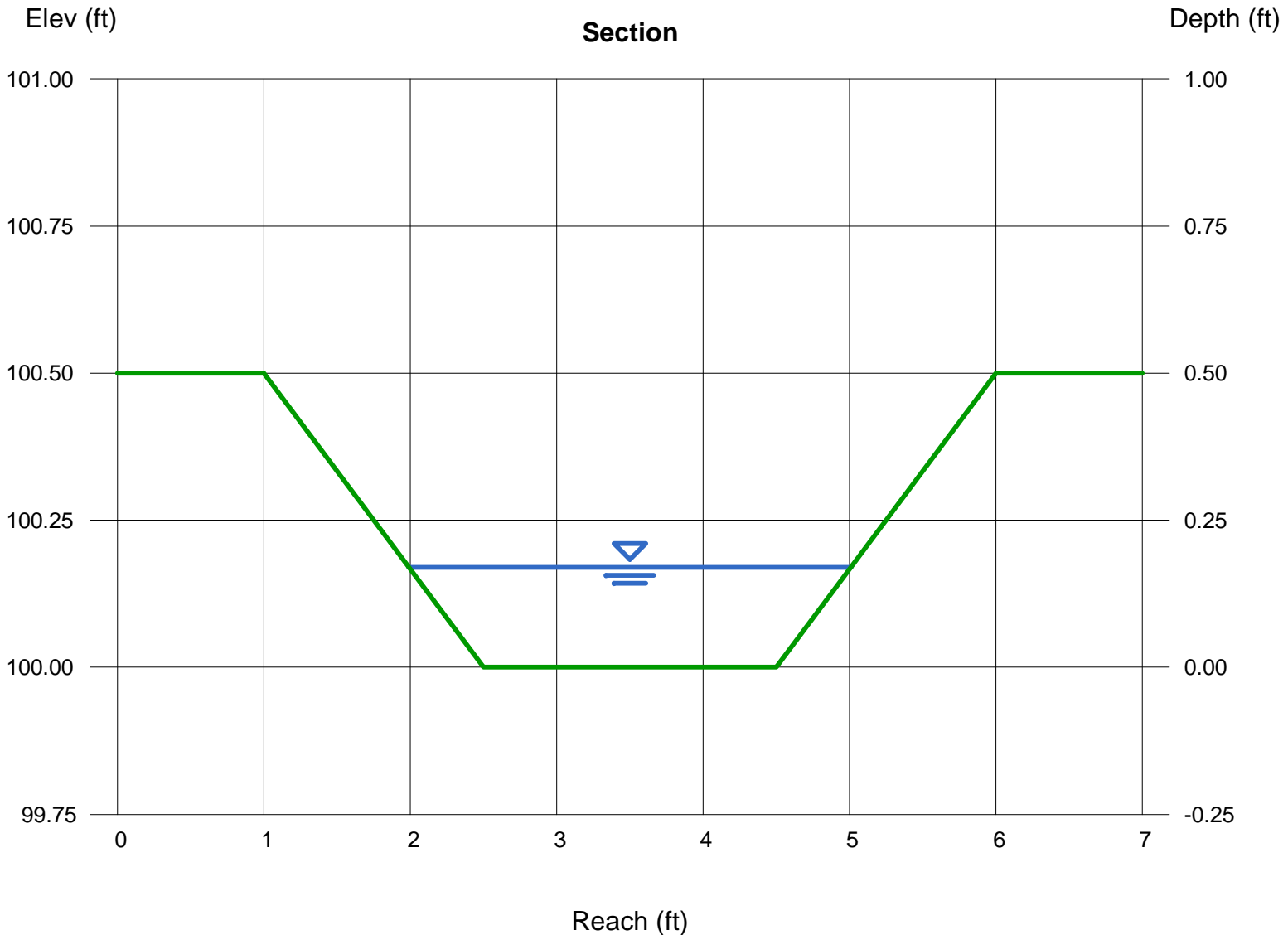

Vegetated Swale

Table VS-3. Design Data Summary Sheet for Vegetated Swale

Designer:	John Smith	Date:	3/17/2014
Company:	ABCD Engineering		
Project:	Auto Dealership		
Location:	Along front side of proposed building		
1. Design Flow: $WQF = I \times C \times A$		WQF =	0.08 cfs
I = Design Intensity = 0.18 in/hr		I =	0.18 in/hr
C = Runoff Coefficient		C =	1.0
A = Tributary Area		A =	0.44 acres
2. Swale Geometry			
Swale Bottom Width (b)		b =	2.0 Ft
Side slope (Z)		Z =	3:1
3. Depth of flow (d) at WQF (3" to 5" with Manning's n=0.20)		d =	2.04 in
4. Design Slope			
s = 1% minimum without underdrains, 4% maximum without grade controls		s =	1.0 %
Number of grade controls required			N/A
5. Design flow velocity (Manning's n=0.20)		v =	0.19 ft/sec
6. Contact Time ( $t_c = 7$ minutes minimum)		$t_c =$	7.9 Minutes
7. Design Length, $L = (t_c) \times (\text{flow velocity}) \times 60$		L =	90 ft
8. Vegetation (describe):			4" to 6" high grass
9. Outflow Collection (Check type used or describe "Other")			
<input type="checkbox"/> Grated Inlet	<input type="checkbox"/> Infiltration Trench	<input type="checkbox"/> Underdrain Used	
<input checked="" type="checkbox"/> Other	Discharge to adjacent underground vault.		
Notes:			

Porous Pavement Subgrade Storage Volume

169,884 sf	Tributary Drainage Area
7,786 cf	Water Quality Volume
13,939 cf	Volume Provided

Volume provided in void space of porous pavement subgrade exceed WQV.

# Appendix B. Maintenance Requirements

THIS PAGE INTENTIONALLY LEFT BLANK

# Appendix B Maintenance Requirements

---

## State Mandated Requirement

Verification of long-term maintenance provisions for post-construction structural and treatment control measures is mandated by the agencies' State-issued stormwater permits. For example, the Sacramento Areawide NPDES Municipal Stormwater Permit (No. CASo82597) specifies:

*22. Maintenance Agreement and Transfer: Each Permittee shall require that all developments subject to Development Standards and site specific plan requirements provide verification of maintenance provisions for Structural Treatment Control BMPs, including but not limited to legal agreements, covenants, California Environmental Quality Act (CEQA) mitigation requirements, and or conditional use permits. Verification at a minimum shall include:*

- a. The developer's signed statement accepting responsibility for maintenance until the responsibility is legally transferred; or*
- b. Written conditions in the sales or lease agreement, which requires the recipient to assume responsibility for maintenance; or*
- c. Written text in project conditions, covenants and restrictions for residential properties assigning maintenance responsibilities to the Home Owners Association for maintenance of Structural Treatment Control BMPs; or*
- d. Any other legally enforceable agreement that assigns responsibility for the maintenance of post-construction Structural Treatment Control BMPs.*

## Maintenance Agreements, Covenants or Permits

In compliance with this regulation, the local permitting agencies in the Sacramento area have decided that they will require execution of a maintenance agreement, covenant or permit with the property owner for projects using any of the following control measures (refer to Chapter 5):

- Underground Storage
- Porous Pavement
- Green Roof
- Constructed Wetland Basin
- Water Quality Detention Basin
- Infiltration Basin

- Infiltration Trench
- Sand Filter
- Bioretention Planter
- Vegetated Swale
- Proprietary Devices

Typically maintenance agreements and covenants are recorded with the deed for the property and follow property ownership. The agreements generally include provisions for the permitting agency to recover costs for maintenance in the event that the property owner fails to fulfill their obligations. Check with the local permitting agency about the timing for execution of the agreement.

## Recommended Inspection and Maintenance Procedures

A stand-alone table listing recommended inspection and maintenance procedures is provided at the end of the fact sheet for each of the above control measures. The intent is for the applicable table(s) to be incorporated into the maintenance agreement for the project with amendments as needed by the project designer and property owner to pertain to the unique project conditions. It is the responsibility of the project designer to inform the permitting agency of the complete set of necessary inspection and maintenance requirements that will provide long-term continued performance and sustainability of the measures.

## Reconstruction or Replacement of Failed Facilities

In addition to inspecting and performing maintenance on the stormwater quality control measure(s), the property owner will be required by the maintenance agreement or permit to reconstruct or replace the measure when it ceases to function properly. For informational purposes, the table on the next page summarizes projected life span information for the various stormwater quality control measures, based on available literature.

## Example Maintenance Agreements

Each agency will likely use a different format for the maintenance verification. For example purposes, two standard maintenance covenants/agreements are provided at the end of this appendix, for the County of Sacramento and City of Sacramento, respectively. The contents of each form are basically the same.

## Resources for Additional Guidance

*Maintaining Your Stormwater Management Facility: Homeowner Handbook*, City of Portland, OR.  
<http://www.portlandonline.com/shared/cfm/image.cfm?id=65926>



## Expected Life for Selected Stormwater Quality Control Measures (Based on Published Literature)

Control Measure	Average Life Expectancy <sup>1</sup>	Source/Reference
Underground Storage		
Porous Pavement <sup>2</sup>	20 years	Maintaining Your Stormwater Management Facility: Homeowner Handbook, City of Portland, OR. <a href="http://www.portlandonline.com/shared/cfm/image.cfm?id=65926">http://www.portlandonline.com/shared/cfm/image.cfm?id=65926</a>
	30 years	<a href="http://www.seattle.gov/dpd/static/GF_RainGardens_1_37427_DPDP_019875.pdf">http://www.seattle.gov/dpd/static/GF_RainGardens_1_37427_DPDP_019875.pdf</a>
Disconnected Pavement		
Alternative Driveway		
Disconnected Roof Drains		
Interceptor Trees		
Green Roof	10-40 years	<a href="http://www.ecoroofsystems.com/cost_files/c_cost.html">http://www.ecoroofsystems.com/cost_files/c_cost.html</a>
Capture and Re-Use		
Compost Amended Soil		
Constructed Wetland Detention Basin	20 years	<a href="http://www.epa.gov/superfund/programs/aml/tech/cuwetlands.pdf">http://www.epa.gov/superfund/programs/aml/tech/cuwetlands.pdf</a>
Water Quality Detention Basin	25 years and more	<a href="http://www.abe.msstate.edu/csd/p-dm/all-chapters/chapter4/chapter4/det-basin.pdf">http://www.abe.msstate.edu/csd/p-dm/all-chapters/chapter4/chapter4/det-basin.pdf</a>
Infiltration Basin	NA	Information to be provided in a future update.
Infiltration Trench	30 years	<a href="http://www.portlandonline.com/shared/cfm/image.cfm?id=65926">http://www.portlandonline.com/shared/cfm/image.cfm?id=65926</a>
	5-15 years	<a href="http://www.epa.gov/owmitnet/mtb/infiltrenc.pdf">http://www.epa.gov/owmitnet/mtb/infiltrenc.pdf</a>
Sand Filter	5-20 years	<a href="http://www.fhwa.dot.gov/environment/ultraurb/3fs7.htm">http://www.fhwa.dot.gov/environment/ultraurb/3fs7.htm</a>
Bioretention Planter	NA	Information to be provided in a future update.
Vegetated Filter Strip	50 years	<a href="http://www.portlandonline.com/shared/cfm/image.cfm?id=65926">http://www.portlandonline.com/shared/cfm/image.cfm?id=65926</a>
Vegetated Swale	20 years	<a href="http://www.highwaybmp.dfwinfo.com/FHWA_PDF/Grassed%20Swale.pdf">http://www.highwaybmp.dfwinfo.com/FHWA_PDF/Grassed%20Swale.pdf</a>
	No known limit	<a href="http://www.epa.gov/nrmrl/pubs/600r04121/600r04121asect6.pdf">http://www.epa.gov/nrmrl/pubs/600r04121/600r04121asect6.pdf</a>
<p>NA: Not available</p> <p>1: Information is based on cited references/sources and assuming proper design, installation and long term maintenance. Life expectancy may vary depending on the design. The studies cited in this table may not have used the same design criteria as specified in this design manual.</p> <p>2: Expected life estimated to increase with increased pavement depth.</p>		

THIS PAGE LEFT INTENTIONALLY BLANK

# Sample Agreements

The following “Stormwater Treatment Measure Access and Maintenance Agreement” and “Declaration of Covenants (Device Maintenance and Access)” are sample agreements for reference only.

THIS PAGE INTENTIONALLY LEFT BLANK

Recorded at the request of:  
CITY OF SACRAMENTO  
DEPARTMENT OF UTILITIES  
No Fee per Government Code 6130

\_\_\_\_\_  
After recording, return to:  
Office of the City Clerk  
Historic City Hall  
915 "I" Street, 1st Floor  
Sacramento CA 95814

**STORMWATER TREATMENT MEASURE  
ACCESS AND MAINTENANCE AGREEMENT**

**OWNER:** \_\_\_\_\_

**PROPERTY ADDRESS:** \_\_\_\_\_

**APN:** \_\_\_\_\_

**THIS AGREEMENT** is made and entered into in Sacramento, California, this \_\_\_\_\_ day of \_\_\_\_\_ 20\_\_\_\_, by and between \_\_\_\_\_ ("Owner"), and the CITY OF SACRAMENTO, a municipal corporation ("City").

**WHEREAS**, the Owner owns real property (the "Property") in the City of Sacramento, County of Sacramento, State of California, more specifically described in Exhibit "A" and depicted in Exhibit "B", each of which exhibits is attached hereto and incorporated herein by this reference; and

**WHEREAS**, at the time of initial approval of the development project on the Property known as \_\_\_\_\_, the City's conditions of approval included a requirement for the Project to employ on-site control measures to minimize pollutants in urban runoff; and

**WHEREAS**, the Owner has chosen to install \_\_\_\_\_ (collectively referred to herein as the "Measure"), as the on-site control measure to minimize pollutants in urban runoff; and

**WHEREAS**, the Measure has been installed in accordance with plans and specifications accepted by the City; and

**WHEREAS**, the Measure, with installation on private property and draining only private property, is a private facility and all maintenance or replacement of the Measure is the sole responsibility of the Owner in accordance with the terms of this Agreement; and

**WHEREAS**, the Owner is aware and agrees that periodic and continuous maintenance, including, but not necessarily limited to, removal of sediment, trash and debris, maintenance of vegetation, and repairs to any ruts or holes, is required to assure peak performance of the Measure and that, furthermore, such maintenance activity will require compliance with all local, State, or Federal laws and regulations, including those pertaining to waste disposal methods, in effect at the time such maintenance occurs.

**NOW THEREFORE**, it is mutually stipulated and agreed as follows:

1. The foregoing recitals are incorporated herein by this reference.
2. Owner hereby provides the City or City's designee complete access to the Measure and its immediate vicinity at any time and for any duration, upon twenty-four (24) hour advance notice in writing, for the purpose of inspection, sampling and testing of the Measure. City shall make every effort at all times to minimize or avoid interference with Owner's use of the Property.
3. Owner shall use its best efforts diligently to maintain the Measure in a manner assuring peak performance at all times, including but not necessarily limited to performance of the maintenance and repair measures specified on Exhibit "C", attached hereto and incorporated herein by this reference. All reasonable precautions shall be exercised by Owner and Owner's representative or contractor in the maintenance of vegetation, the removal and extraction of material(s) from the Measure and the ultimate disposal of the material(s) in a manner consistent with all relevant laws and regulations in effect at the time. As may be requested from time to time by the City, the Owner shall provide the City with documentation identifying the material(s) removed, the quantity, and disposal destination. In addition, Owner shall provide maintenance reports to the City on an annual basis, not later than 60 days after receiving City's maintenance report request.
4. If Owner, or its successors or assigns, fails to accomplish the necessary maintenance contemplated by this Agreement, within five (5) days of being given written notice by the City, the City is hereby authorized (but shall not have any obligation) to cause any maintenance necessary to be done and charge the entire cost to the Owner or Owner's successors or assigns, including administrative costs and interest thereon at the maximum rate authorized by the Civil Code from the date of notice of the cost until paid in full.
5. The City may require the Owner to post security in a form and for a time period satisfactory to the City, to guarantee performance of the obligations stated herein. Should the Owner fail to perform its obligations as required under this Agreement, the City may, in the case of a cash deposit or letter of credit, use the proceeds to pay costs incurred by the City to take any action(s) authorized by this Agreement, or in the case of a surety bond, the City may require the sureties to perform the Owner's obligations under the Agreement.
6. This Agreement shall be recorded in the Office of the Recorder of Sacramento County, California, at the expense of the Owner and shall constitute notice to all successors and assigns of the title to the Property of the obligations herein set forth, and also a lien in such amount as will fully reimburse the City for costs incurred pursuant to Section 4, above, including interest as hereinabove set forth, subject to foreclosure in event of default in payment.
7. In the event of legal action occasioned by any uncured default of the Owner, or its successors or assigns, then the prevailing party shall recover all costs incurred, including reasonable attorney's fees and costs.
8. It is the intent of the parties hereto that burdens and benefits herein undertaken shall

constitute covenants that run with the Property and constitute a lien against the Property.

9. The obligations herein undertaken shall be binding upon the heirs, successors, executors, administrators and assigns of the parties hereto. The term "Owner" shall include not only the present Owner, but also its heirs, successors, executors, administrators, and assigns. Owner shall notify any successor to title of all or any part of the Property of the existence of this Agreement. Owner shall provide such notice prior to such successor obtaining an interest in all or part of the Property. Owner shall provide a copy of such notice to the City at the same time such notice is provided to the successor. If an Owner shall convey all of its interest in the Property, the Owner shall be released from any obligations arising under this Agreement in connection with the maintenance of or failure to maintain the Measure occurring after the date of such conveyance.
10. Time is of the essence in the performance of this Agreement.
11. Any notice to a party required or called for in this Agreement shall be served in person, or by deposit in the U.S. Mail, first class postage prepaid, to the address set forth below. Notice(s) shall be deemed effective upon receipt, or seventy-two (72) hours after deposit in the U.S. Mail, whichever is earlier. A party may change a notice address only by providing written notice thereof to the other party.

IF TO CITY:

Director of Utilities – Stormwater Program  
City of Sacramento, Department of Utilities  
1395 35<sup>th</sup> Avenue  
Sacramento, CA 95822

IF TO OWNER:

---

---

---

---

12. If Owner consists of more than one party, each person, entity or other party described as the "Owner" in the first paragraph of this Agreement and/or executing this Agreement for Owner shall be jointly and severally liable for each and every obligation and requirement imposed on Owner herein.
13. The Owner acknowledges and agrees that nothing contained in this Agreement reduces or otherwise affects Owner's responsibility to comply with all applicable provisions of the City of Sacramento's Stormwater Management and Discharge Control Code, set forth in Chapter 13.16 of the Sacramento City Code, and nothing contained in this Agreement shall in any way limit the City's right to enforce any provisions of the Stormwater Management and Discharge Control Code in accordance with the provisions of that Code.

**IN WITNESS THEREOF**, the parties hereto have affixed their signatures as of the date first written above.

**APPROVED AS TO FORM:**

\_\_\_\_\_  
City Attorney

**CITY OF SACRAMENTO:**

\_\_\_\_\_  
William O. Busath  
Director, Department of Utilities

**ATTEST:**

\_\_\_\_\_  
City Clerk

\_\_\_\_\_  
Date

**OWNER:**

\_\_\_\_\_  
Signature of Authorized Person

Print Name: \_\_\_\_\_

Title: \_\_\_\_\_

**NOTARIES ON FOLLOWING PAGE**



THIS PAGE LEFT INTENTIONALLY BLANK

**EXHIBIT A**  
***[Legal Description of Parcel]***

**EXHIBIT B**  
***[Map/Illustration]***

**EXHIBIT C**  
***[Inspection and Maintenance Guidelines]***

RECORDING REQUESTED BY and for the BENEFIT OF:

NAME Sacramento County  
Department of Water Resources  
MAILING ADDRESS 827 7th Street, Rm. 301  
CITY, STATE Sacramento, CA 95814  
ZIP CODE  
INTEROFFICE MAIL: Mail Code 01-301

**NO FEE DOCUMENT  
Gov. Code § 6103**

(rev. 8-13)

SPACE ABOVE THIS LINE RESERVED FOR RECORDER'S USE

**DECLARATION OF COVENANT  
(Device Maintenance and Access)**

**THIS DECLARATION OF COVENANT** ("Declaration") is executed as of \_\_\_\_\_, 201\_\_\_\_, by \_\_\_\_\_ a \_\_\_\_\_, (hereinafter the "Declarant") with reference to the following facts:

A. Declarant is the owner of that certain real property, commonly referred to as Assessor's Parcel Number ("APN"), and more particularly described on Exhibit "A" and the plat thereof on Exhibit "B," attached hereto and incorporated by reference herein (hereinafter, the "Subject Property"). Subject Property is located within the County of Sacramento, California, a political subdivision of the State of California (hereinafter, "Sacramento County").

B. At the time of Sacramento County's initial approval of the development project known as \_\_\_\_\_ wherein the Subject Property is located, Sacramento County required installation of onsite control measures to minimize pollutants in urban runoff.

C. Declarant has chosen to install \_\_\_\_\_ hereinafter referred to as the "Device," as the on-site control measure to minimize pollutants in urban runoff.

D. The Device has been installed in accordance with plans and specifications accepted by Sacramento County.

E. The Device, being installed on private property and draining only private property, is a private facility, and all maintenance or replacement of the Device is the sole responsibility of the Declarant in accordance with the terms of this Declaration.

F. The Declarant is aware that periodic and continuous maintenance, including, but not necessarily limited to, filter material replacement and sediment removal, is required to assure peak performance of the Device in accordance with the maintenance procedures prepared for the Device which maintenance procedures are attached hereto as Exhibit "C" and incorporated herein.

G. Maintenance of the Device will require compliance with all Local, State, or Federal laws and regulations, including those pertaining to confined space and waste disposal methods, in effect at the time such maintenance occurs.

H. In the event a Device failure results in pollutants being discharged into the County storm drain system, the Declarant shall be responsible for all costs of cleanup. The terms 'pollutants' and 'County storm drain system' are used herein as defined in Sacramento County Code Chapter 15.12.

**NOW THEREFORE**, in consideration of the foregoing benefits, as well as the benefits obtained by the Declarant and other valuable consideration, the receipt and adequacy of which is hereby acknowledged, Declarant hereby declares as follows:

1. **Covenant Running with Land**. The Declarant does hereby covenant that the burdens and benefits herein made and undertaken shall constitute covenants running with the Subject Property and constitute an encumbrance on said Subject Property which shall bind successors.
2. **Declarant Responsibility to Maintain**: Declarant, its successors or assigns, shall at all times maintain the Device in accordance with requirements stated in Exhibit "C" and in a manner assuring the Device's peak performance at all times. All reasonable precautions shall be exercised by Declarant and Declarant's representatives in the removal and extraction of material(s) from the Device. Disposal of the material(s) shall be performed in a manner consistent with all relevant laws and regulations in effect at the time of removal. For a time period of the most recent three (3) years, Declarant shall maintain written documentation verifying all material(s) removed from the Device, including identifying the material(s) removed, quantity, and manner and place of disposal thereof. Such documentation shall be provided to Sacramento County annually by May 1.
3. **Failure to Maintain**: In the event Declarant, or its successors or assigns, fails to maintain the Device as required by this Declaration, after thirty (30) days written notice thereof, Sacramento County may and is hereby authorized to cause, at the Declarant's expense, any and all maintenance to the Device necessary under the requirements specified in Exhibit "C." In addition to the actual costs of such maintenance, the Declarant shall reimburse Sacramento County for an additional fifteen percent (15%) thereof to cover costs of administration. All such actual and administrative costs shall accrue interest from the date incurred by Sacramento County at the maximum rate authorized by law until paid in full. In addition, failure to maintain the Device as required may result in enforcement actions consisting of administrative civil penalties (SCC § 15.12.560) and or criminal penalties (SCC § 15.12.570). The notice provided herein shall be effective on the date sent by U.S. Mail, registered or certified mail, to the record owner of the Subject Property as shown on the last equalized assessment roll.
4. **Security**: If the Declarant fails to maintain the Device as required by the standards specified in Exhibit "C", Sacramento County may require the Declarant, at the Declarant's sole cost, to post security in a form, for a time period, and in an amount satisfactory to Sacramento County, to guarantee the Declarant's performance of the obligations set forth herein. Should the Declarant fail to perform the obligations under this Declaration, Sacramento County may realize against said security, and in the case of a cash bond, act for the Declarant using the proceeds from it, or in the case of a surety bond, require the sureties to perform the obligations of this Declaration. Said security shall be available to Sacramento

County to satisfy the Declarant's reimbursement obligation under paragraph 3.

5. **Access by County:** Declarant grants Sacramento County or the County's designee the unrestricted right of access to the Device, including its immediate vicinity as well as ingress and egress to and from said Device over Subject Property, at any time, upon twenty-four (24) hour advance notice in writing, of any duration for the purpose of inspection, sampling and testing of the Device. Sacramento County shall make reasonable efforts at all times to minimize or avoid interference with Declarant's use of the Subject Property.

6. **Successors and Assigns Bound:** Declarant hereby agrees and acknowledges that maintenance of the Device as set forth herein, the costs of Device maintenance, Sacramento County's access to the Device, Sacramento County's rights of ingress and egress to the Device, and Sacramento County's rights to recovery of costs if Declarant fails to maintain the Device are a burden and restriction on the use of the Subject Property. The provisions of this Declaration shall be enforceable as an equitable servitude and as conditions, restrictions and covenants running with the land, and shall be binding upon the Declarant and upon each and all of its respective heirs, devisees, successors, and assigns, officers, directors, employees, agents, representatives, executors, trustees, successor trustees, beneficiaries and administrators, and upon any future owners of the Subject Property and each of them.

7. **Enforcement:** It is the express intent of the Declarant that the terms and provisions of this Declaration shall be enforceable as an equitable servitude. To the extent necessary to do so, Declarant and its successors and assigns hereby confer and assign rights to enforce the terms and conditions of this Declaration to Sacramento County.

8. **Recording of Agreement:** This Declaration shall be recorded in the Office of the Recorder of Sacramento County, California and shall constitute notice to all successors and assigns of the title to the Subject Property of the rights and obligations herein set forth.

9. **Amendment:** This Declaration may be amended by Declarant, but only if in writing, and only after written approval of Sacramento County.

IN WITNESS WHEREOF, Declarant has executed this Declaration as of the day and year written above.

SAMPLE

DECLARANT:

By: \_\_\_\_\_

Its: \_\_\_\_\_

[attach]

DECLARANT'S ACKNOWLEDGEMENT

- Exhibit "A" Legal Description of Subject Property
- Exhibit "B" Plat of Subject Property (with device locations)
- Exhibit "C" Device Maintenance Requirements

THIS PAGE LEFT INTENTIONALLY BLANK



# Appendix C. Connecting to the Sanitary Sewer System General Requirements

---

THIS PAGE INTENTIONALLY LEFT BLANK

# Appendix C Connecting to the Sanitary Sewer System: General Information

---

## Unincorporated Sacramento County and the Cities of Citrus Heights, Elk Grove, Folsom and Rancho Cordova

Sanitary sewer collection service is provided by County Sanitation District 1 (CSD-1); all wastewater is treated by the Sacramento Regional County Sanitation District (SRCSD) at the Sacramento Regional Wastewater Treatment Plant (SRWTP) in Elk Grove.<sup>1</sup>

To install or replace sewer pipelines for new business or residence, both a building permit and a sewer impact (connection) permit will be required. If public right of way or publicly owned property will be used, an encroachment permit will be required. Building and encroachment permits are issued by the County for the unincorporated area or by the applicable city. The sewer connection permit is issued by CSD-1. The purposes of these permits are to ensure that plumbing is installed safely and legally and that everyone pays their fair share of the cost to construct the wastewater collection and treatment system (pipelines and treatment plant). Permits are not required for "spot repairs" (such as line replacement under 10 feet in length, or cleanout installation).

Sewer impact (connection) fees must be calculated by the CSD-1/SRCSD Permit Services Unit. Refer to CSD-1's web site ([www.csd-1.com](http://www.csd-1.com)) or SRCSD's website at [www.srcsd.com](http://www.srcsd.com) and call 876-6100 for a fee quote.

A \$45 inspection fee will be collected at the time of permit issuance for all pipes within the County of Sacramento.

## City of Sacramento

Sanitary sewer collection service is either provided by the City of Sacramento or CSD-1, depending on the service area. Within the City's service area, the City operates a combined sewer system (CSS) that collects both sewage and drainage for the area. Wastewater treatment for these areas is provided by the SRCSD.

All development projects within the City will be charged sewer impact fees:

- For projects served by the City-owned collection system, the project will be charged a City sewer/CSS development fee and must pay the SRCSD sewer impact fee (connection fee). The City's development fee will be charged through the City's building permit process.

---

<sup>1</sup> CSD-1 covers sewer service from a residence or business (via what CSD calls the "little pipes") to SRCSD's "Interceptor System" (the "big pipes") that connect to the Sacramento Regional Wastewater Treatment Plant.

- For projects served by CSD-1, the project must pay the CSD-1 and SRCSD sewer impact (connection) fees.

## City of Folsom

The City of Folsom owns and operates its own sanitary sewer collection system which eventually ties into to SRCSD's interceptor system and is treated by the SRCSD at their plant in Elk Grove.

Development projects in Folsom will be charged a City connection/impact fee and the SRCSD treatment fee.

## City of Galt

Sanitary sewer collection service and wastewater treatment is provided by the City of Galt. Proposed sanitary sewer connections must be identified during the project application stage and will be reviewed on a case by case basis by the City's Public Works Department. Contact the City of Galt Public Works Department at (209) 366-7280.

# Appendix D. Low Impact Development Credits and Calculation Worksheets

---

THIS PAGE INTENTIONALLY LEFT BLANK

## Appendix D

### LID Credit Calculation Worksheets

- Appendix D-1 Worksheet for Residential Projects
- Appendix D-2 Worksheet for Commercial Projects
- Appendix D-3 Runoff Reduction Credit Criteria
- Appendix D-4 Background Report and References

**Appendix D-1: Residential Sites: Low Impact Development (LID) Credits and Treatment BMP Sizing Calculations**

Name of Drainage Shed:  Fill in Blue Highlighted boxes  
 Location of project:  Sacramento

**Step 1 - Open Space and Pervious Area Credits**

Is your project within the drainage area of a common drainage plan that includes open space? If not, skip to 1 b.

**1 a. Common Drainage Plan Area**  acres  $A_{CDP}$

**Common Drainage Plan Open Space (Off-project)**  acres  $A_{OS}$  **see area example below**

a. Natural storage reservoirs and drainage corridors  0 acres

b. Buffer zones for natural water bodies  0 acres

c. Natural areas including existing trees, other vegetation, and soil  0 acres

d. Common landscape area/park  0 acres

e. Regional Flood Control/Drainage basins  0 acres

**1 b. Project Drainage Shed Area (Total)**  acres  $A$

**Project-Specific Open Space (In-project, communal\*\*)**  acres  $A_{PSOS}$  **see area example below**

a. Natural storage reservoirs and drainage corridors  0.00 acres

b. Buffer zones for natural water bodies  0.00 acres

c. Natural areas including existing trees, other vegetation, and soil  0.00 acres

d. Landscape area/park  0.00 acres

e. Flood Control/Drainage basins  0.00 acres

\*\* Doesn't include impervious areas within individual lots and surrounding individual units. That is accounted for below using Form D-1a in Step 2.

**Area with Runoff Reduction Potential**  $A - A_{PSOS} =$   0.00 acres  $A_T$

**Number of Units in  $A_T$**

**Number of units per acre in  $A_T$**   $DU/A_T =$   0  $DUA$

**Assumed Initial Impervious Fraction of  $A_T$**   #N/A  $I$   
 (determined using Table D-1a)

**Open Space & Pervious Area LID Credit (Step 1)**  
 $(A_{OS}/A_{CDP} + A_{PSOS}/A) \times 100 =$   #DIV/0! pts

Dwelling units per acre	Imperviousness
1	0.17
2	0.25
3,4	0.35
5,6	0.40
7	0.50
8,9	0.55
10-14	0.60
15-20	0.70

	<b>A - Drainage Shed Area</b>
	<b><math>A_{PSOS}</math> - Parks and Open Space</b>
	<b><math>A_T</math> - Area with Runoff Reduction Potential</b>

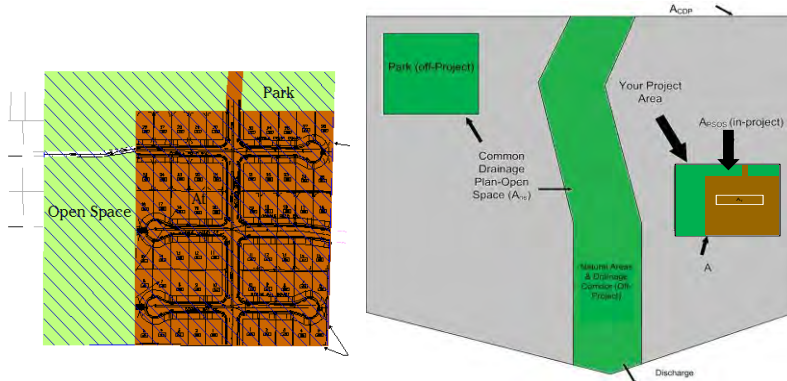

**Step 2 - Runoff Reduction Credits**

Runoff Reduction Measures	Effective Area Managed ( $A_C$ )
<b>Disconnected Roof Drains</b> (see Fact Sheet) use Form D-1a for credits	<input type="text"/> 0.00 acres
<b>Disconnected Pavement</b> (see Fact Sheet) use Form D-1b for credits	<input type="text"/> 0.00 acres
<b>Interceptor Trees</b> (see Fact Sheet) use Form D-1c for credits	<input type="text"/> 0.00 acres
<b>Alternative Driveway Design</b> (see Fact Sheet) use Form D-1d for credits	<input type="text"/> 0.00 acres
<b>Total Effective Area Managed (Credit Area)</b>	$A_C$ <input type="text"/> 0.00 acres <b>EAM</b>

**Runoff Reduction Credit (Step 2)**  $(A_C / A_T) * 100 =$   #DIV/0! pts



**Form D-1a: Disconnected Roof Drains Worksheet**

See Fact Sheet for more information regarding Disconnected Roof Drain credit guidelines

Effective Area Managed (Ac)

1. Determine efficiency Multiplier

Runoff is directed to a dispersal trench or dry well (Type A and B soils only)		1.00
Runoff is directed across landscaping, determine setback		
25 ft +	Use multiplier of	1.00
≥ 20 and < 25 ft	Use multiplier of	0.90
≥ 15 and < 20 ft	Use multiplier of	0.70
≥ 10 and < 15 ft	Use multiplier of	0.45
≥ 5 and < 10 ft	Use multiplier of	0.25

Efficiency Multiplier →  Box J1

2. Determine percentage of roof drains disconnected

→  Box J2

3. Select project density in dwelling units per acre:

1	Use reduction factor of	0.08
2	Use reduction factor of	0.13
3,4	Use reduction factor of	0.19
5,6	Use reduction factor of	0.23
7	Use reduction factor of	0.29
8,9	Use reduction factor of	0.33
10-14	Use reduction factor of	0.37
15-20	Use reduction factor of	0.44

Reduction Factor →  Box J3

4. Determine Area Managed

Multiply Box J3 by A<sub>T</sub>, and enter the result in Box J4  acres Box J4

5. Multiply Boxes J1, J2 and J4, and enter 60% of the Result in Box J

acres Box J

This is the amount of area credit to enter into the "Disconnected Roof Drains" Box of Form D-1

**Form D-1b: Disconnected Pavement Worksheet**

See Fact Sheet for more information regarding NDC Pavement credit guidelines

Effective Area Managed (Ac)

**Divided Sidewalks**

1. Determine percentage of units with divided Sidewalks

Box K1

Multiply Box K1, A<sub>T</sub>, and 0.04 and enter 60% of the result in Box K

acres Box K

This is the amount of area credit to enter into the "Disconnected Pavement" Box of Form D-1

**Form D-1c: Interceptor Tree Worksheet**

See Fact Sheet for more information regarding Interceptor Tree credit guidelines

Effective Area Managed (Ac)

**New Evergreen Trees**

1. Enter number of new evergreen trees that qualify as Interceptor Trees in Box L1.

trees Box L1

2. Multiply Box L1 by 200 and enter result in Box L2

sq. ft. Box L2

**New Deciduous Trees**

3. Enter number of new deciduous trees that qualify as Interceptor Trees in Box L3.

trees Box L3

4. Multiply Box L3 by 100 and enter result in Box L4

sq. ft. Box L4

**Existing Tree Canopy**

5. Enter square footage of existing tree canopy that qualifies as Existing Tree canopy in Box L5.

sq. ft. Box L5

6. Multiply Box L5 by 0.5 and enter the result in Box L6

sq. ft. Box L6

**Total Interceptor Tree Credits**

Add Boxes L2, L4, and L6 and enter it into Box L7

sq. ft. Box L7

Divide Box L7 by 43,560 and multiply by 20% to get effective area managed and enter the result in Box L8

acres Box L8

This is the amount of area credit to enter into the "Interceptor Trees" Box of Form D-1

**Form D-1d: Alternative Driveway Design**

See Fact Sheet for more information regarding Alternative Driveway Design credit guidelines

1. Select type of driveway

Pervious Driveway:	Multiplier:
Cobblestone Block P	0.40
Pervious Concrete/A	0.60
Modular Block	0.75
Porous Pavement	
Porous Gravel	1.00
Not Directly-connected	

Box M1

2. Determine percentage of units with Alternative Driveways:

Box M2

4. Multiply Boxes M1, M2, A<sub>T</sub> and 0.04, and enter the result in Box M

This is the amount of area credit to enter into the "Alternative Driveway Design" Box of Form D-1

acres

**Step 3 - Runoff Management Credits**

**Capture and Use Credits**

**Impervious Area Managed by Rain barrels, Cisterns, and automatically-emptied systems**

(see Fact Sheet)

 enter gallons, for simple rain barrels  acres

**Automated-Control Capture and Use System**

(see Fact Sheet, then enter impervious area managed by the system)

 acres

**Bioretention/Infiltration Credits**

**Impervious Area Managed by Bioretention BMPs**

(see Fact Sheet)

Bioretention Area  sq ft  
 Subdrain Elevation  inches  
 Ponding Depth, inches  inches  acres

**Impervious Area Managed by Infiltration BMPs**

(see Fact Sheet)

Drawdown Time, hrs  drawdown\_hrs\_inf  
 Soil Infiltration Rate, in/hr  soil\_inf\_rate  
 Sizing Option 1: Capture Volume, acre-ft  capture\_vol\_inf  acres  
 Sizing Option 2: Infiltration BMP surface area, sq ft  soil\_surface\_area  acres  
 Basin or trench?  approximate BMP depth  ft

**Impervious Area Managed by Amended Soil or Mulch Beds**

(see Fact Sheet)

Mulched Infiltration Area, sq ft  mulch\_area  acres

**Total Effective Area Managed by Capture-and-Use/Bioretention/Infiltration BMPs**

 A<sub>LIDc</sub>

**Runoff Management Credit (Step 3)**

A<sub>LIDc</sub>/A<sub>T</sub>\*200 =  pts

**Total LID Credits (Step 1+2+3)**

#DIV/0! #DIV/0!

Does project require hydromodification management? If yes, proceed to using SacHM.

**Adjusted Area for Flow-Based, Non-LID Treatment**

A<sub>T</sub> - A<sub>C</sub> - A<sub>LIDc</sub> =  A<sub>AT</sub>

**Adjusted Impervious Fraction of A for Volume-Based, Non-LID Treatment**

(A<sub>T</sub>\*I - A<sub>C</sub> - A<sub>LIDc</sub>) / A =  I<sub>A</sub>

**STOP: No additional treatment needed**

**Step 4a Treatment - Flow-Based (Rational Method)**

**Form D-1e**

Calculate treatment flow (cfs):

Flow = Runoff Coefficient x Rainfall Intensity x Adjusted Treatment Area

Determine C Factor using Table D-1b

C

Determine i using Table D-1c (Rainfall Intensity)

i

A<sub>AT</sub> from Step 2

A<sub>AT</sub>

Flow = C \* i \* A<sub>AT</sub>  cfs

**TABLE D-1b**

Development Type	Runoff Coefficient (Rational), C
Single-family areas	0.50
Multi-units, detached	0.60
Apartment dwelling areas	0.70
Multi-units, attached	0.75
User Specified	0.00

**Table D-1c**

Rainfall Intensity	
Roseville	i = 0.20 in/hr
Sacramento	i = 0.18 in/hr
Folsom	i = 0.20 in/hr

**Step 4b Treatment - Volume-Based (ASCE-WEF)**

Calculate water quality volume (Acre-Feet):

$$WQV = \text{Area} \times \text{Maximized Detention Volume (P}_0\text{)}$$

Obtain A from Step 1

A

hrs

Specified Draw Down time

Obtain P<sub>0</sub>: Maximized Detention Volume from figures E-1 to E-4 in Appendix E of this manual using I<sub>a</sub> from Step 2.

P<sub>0</sub>

Calculate treatment volume (acre-ft):

$$\text{Treatment volume} = A \times (P_0 / 12)$$

Acre-Feet

v06232012

Sacramento 5 ESE (7633) - Sacramento County, California  
Capture / Treatment Analysis

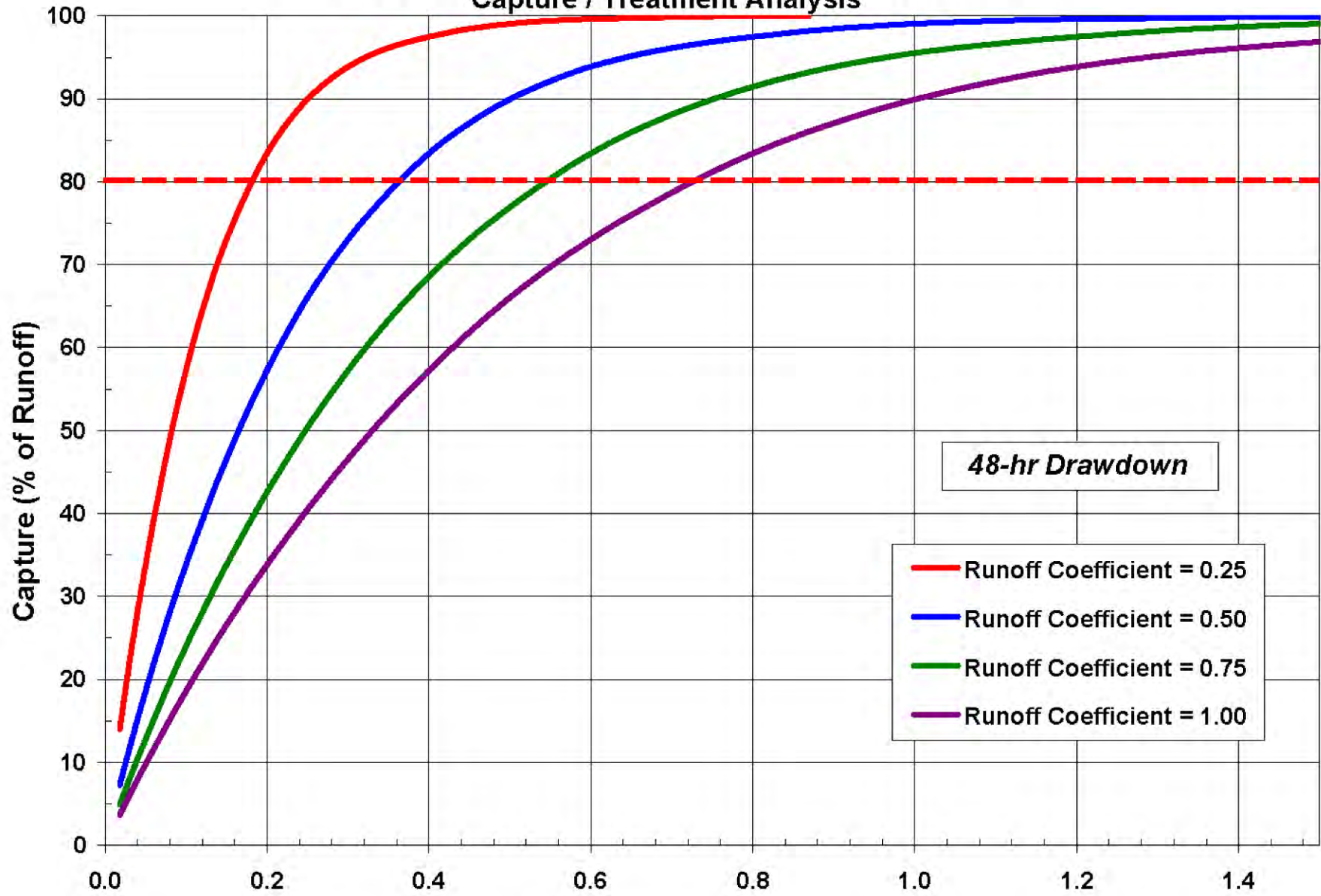

Figure D-1A. Unit Basin Storage Volume (inches)

**Appendix D-2: Commercial Sites: Low Impact Development (LID) Credits and Treatment BMP Sizing Calculations**

Name of Drainage Shed:   
 Location of project:

Fill in Blue Highlighted boxes

**Step 1 - Open Space and Pervious Area Credits**

Is your project within the drainage area of a common drainage plan that includes open space? If not, skip to 1 b.

**1 a. Common Drainage Plan Area**  acres  $A_{CDP}$

**Common Drainage Plan Open Space (Off-project)**

a. Natural storage reservoirs and drainage corridors  acres  $A_{OS}$

b. Buffer zones for natural water bodies  acres

c. Natural areas including existing trees, other vegetation, and soil  acres

d. Common landscape area/park  acres

e. Regional Flood Control/Drainage basins  acres

see area example below

**1 b. Project Drainage Shed Area (Total)**  acres  $A$

**Project-Specific Open Space (In-project, communal\*\*)**

a. Natural storage reservoirs and drainage corridors  acres  $A_{PSOS}$

b. Buffer zones for natural water bodies  acres

c. Natural areas including existing trees, other vegetation, and soil  acres

d. Landscape area/park  acres

e. Flood Control/Drainage basins  acres

see area example below

\*\* Doesn't include impervious areas within individual lots and surrounding individual units. That is accounted for below using Form D-1a in Step 2.

**Area with Runoff Reduction Potential**  $A - A_{PSOS} =$   acres  $A_T$

**Assumed Initial Impervious Fraction**  $A_T / A =$    $I$

**Open Space & Pervious Area LID Credit (Step 1)**  
 $(A_{OS}/A_{CDP} + A_{PSOS}/A) \times 100 =$   pts

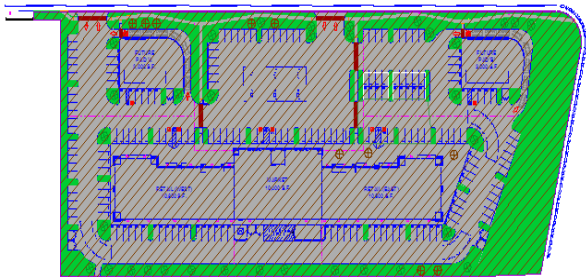

A - Drainage Shed Area  
 Apsos Open Space and Landscaping  
 At - Area with Runoff Reduction Potential

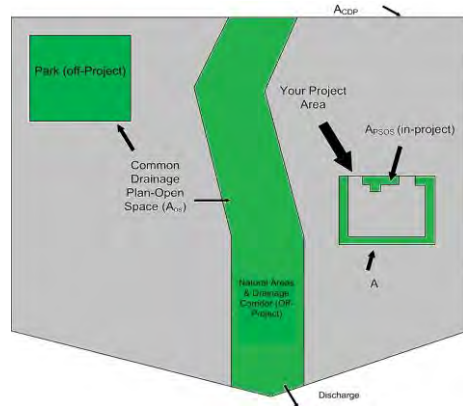

**Step 2 - Runoff Reduction Credits**

Runoff Reduction Treatments	Impervious Area Managed	Efficiency Factor	Effective Area Managed (Ac)
<b>Porous Pavement:</b>			
<b>Option 1: Porous Pavement</b> (see Fact Sheet, excludes porous pavement used in Option 2)	<input type="text" value="0"/> acres	x <input type="text"/>	= <input type="text" value="0.000"/> acres
<b>Option 2: Disconnected Pavement</b> (see Fact Sheet, excludes porous pavement used in Option 1)	use Form D-2a for credits	→	= <input type="text" value="0.00"/> acres
<b>Landscaping used to Disconnect Pavement</b> (see Fact Sheet)	<input type="text" value="0.0000"/> acres		= <input type="text" value="0.00"/> acres
<b>Disconnected Roof Drains</b> (see Fact Sheet and/or Table D-2b for summary of requirements)	<input type="text" value="0"/> acres		= <input type="text" value="0.00"/> acres
<b>Ecoroof</b> (see Fact Sheet)	<input type="text" value="0"/> acres		= <input type="text" value="0.00"/> acres
<b>Interceptor Trees</b> (see Fact Sheet)	use Form D-2b for credits	→	= <input type="text" value="0.00"/> acres
<b>Total Effective Area Managed by Runoff Reduction Measures</b>		$A_C$	= <input type="text" value="0.00"/> acres

**Runoff Reduction Credit (Step 2)**  $(A_C / A_T) \times 100 =$   pts

Table D-2a

Porous Pavement Type	Efficiency Multiplier
Cobblestone Block Pavement	0.40
Pervious Concrete/Asphalt Pavement	0.60
Modular Block Pavement	0.75
Reinforced Grass Pavement	1.00

Table D-2b

Maximum roof size	Minimum travel distance
≤ 3,500 sq ft	21 ft
≤ 5,000 sq ft	24 ft
≤ 7,500 sq ft	28 ft
≤ 10,000 sq ft	32 ft

**Form D-2a: Disconnected Pavement Worksheet**

See Fact Sheet for more information regarding Disconnected Pavement credit guidelines

Effective Area Managed (Ac)

**Pavement Draining to Porous Pavement**

2. Enter area draining onto Porous Pavement  acres Box K1

3. Enter area of Receiving Porous Pavement (excludes area entered in Step 2 under Porous Pavement)  acres Box K2

4. Ratio of Areas (Box K1 / Box K2)  Box K3

5. Select multiplier using ratio from Box K3 and enter into Box K4

Ratio (Box D)	Multiplier
Ratio is ≤ 0.5	1.00
Ratio is > 0.5 and < 1.0	0.83
Ratio is > 1.0 and < 1.5	0.71
Ratio is > 1.5 and < 2.0	0.55

Box K4

6. Enter Efficiency of Porous Pavement (see table below)  Box K5

Porous Pavement Type	Efficiency Multiplier
Cobblestone Block Pavement	0.40
Pervious Concrete Asphalt Pavement	0.60
Modular Block Pavement	0.75
Reinforced Grass Pavement	1.00

7. Multiply Box K2 by Box K5 and enter into Box K6  acres Box K6

8. Multiply Boxes K1, K4, and K5 and enter the result in Box K7  acres Box K7

9. Add Box K6 to Box K7 and multiply by 60%, and enter the Result in Box K8  acres Box K8

This is the amount of area credit to enter into the "Disconnected Pavement" Box of Form D-2

**Form D-2b: Interceptor Tree Worksheet**

See Fact Sheet for more information regarding Interceptor Tree credit guidelines

**New Evergreen Trees**

1. Enter number of new evergreen trees that qualify as Interceptor Trees in Box L1.  trees Box L1
2. Multiply Box L1 by 200 and enter result in Box L2  sq. ft. Box L2

**New Deciduous Trees**

3. Enter number of new deciduous trees that qualify as Interceptor Trees in Box L3.  trees Box L3
4. Multiply Box L3 by 100 and enter result in Box L4  sq. ft. Box L4

**Existing Tree Canopy**

5. Enter square footage of existing tree canopy that qualifies as Existing Tree canopy in Box L5.  sq. ft. Box L5
6. Multiply Box L5 by 0.5 and enter the result in Box L6  sq. ft. Box L6

**Total Interceptor Tree EAM Credits**

- Add Boxes L2, L4, and L6 and enter into Box L7  sq. ft. Box L7
- Divide Box L7 by 43,560 and multiply by 20% to get effective area managed and enter result in Box L8  acres Box L8  
This is the amount of area credit to enter into the "Interceptor Trees" Box of Form D-2

**Step 3 - Runoff Management Credits**

**Capture and Use Credits**

**Impervious Area Managed by Rain barrels, Cisterns, and automatically-emptied systems**

(see Fact Sheet)  - enter gallons, for simple rain barrels  acres

**Automated-Control Capture and Use System**

(see Fact Sheet, then enter impervious area managed by the system)  acres

**Bioretention/Infiltration Credits**

**Impervious Area Managed by Bioretention BMPs**

(see Fact Sheet) Bioretention Area  sq ft  
Subdrain Elevation  inches  
Ponding Depth, inches  inches  acres

**Impervious Area Managed by Infiltration BMPs**

(see Fact Sheet) Drawdown Time, hrs  drawdown\_hrs\_inf  
Soil Infiltration Rate, in/hr  soil\_inf\_rate

Sizing Option 1: Capture Volume, acre-ft  capture\_vol\_inf  acres

Sizing Option 2: Infiltration BMP surface area, sq ft  soil\_surface\_area  acres

Basin or trench?  approximate BMP depth  ft

**Impervious Area Managed by Amended Soil or Mulch Beds**

(see Fact Sheet) Mulched Infiltration Area, sq ft  mulch\_area  acres

**Total Effective Area Managed by Capture-and-Use/Bioretention/Infiltration BMPs**

A<sub>LIDC</sub>

**Runoff Management Credit (Step 3)**

A<sub>LIDC</sub>/A<sub>T</sub>\*200 =  pts

**Total LID Credits (Step 1+2+3)**

#DIV/0! #DIV/0!

Does project require hydromodification management? If yes, proceed to using SachM.

**Adjusted Area for Flow-Based, Non-LID Treatment**

A<sub>T</sub> - A<sub>C</sub> - A<sub>LIDC</sub> =  A<sub>AT</sub>

**Adjusted Impervious Fraction of A for Volume-Based, Non-LID Treatment**

A<sub>AT</sub> / A =  I<sub>A</sub>

**STOP: No additional treatment needed**

**Step 4a Treatment - Flow-Based (Rational Method)**

Calculate treatment flow (cfs):

$$\text{Flow} = \text{Runoff Coefficient} \times \text{Rainfall Intensity} \times \text{Area}$$

Look up value for  $i$  in Table D-2c (Rainfall Intensity)

**Table D-2c**

Rainfall Intensity		
Roseville	$i =$	0.20 in/hr
Sacramento	$i =$	0.18 in/hr
Folsom	$i =$	0.20 in/hr

Obtain  $A_{AT}$  from Step 3

$A_{AT}$

Use  $C = 0.95$

$C$

$$\text{Flow} = 0.95 \cdot i \cdot A_{AT}$$

cfs



**Step 4b Treatment - Volume-Based (ASCE-WEF)**

Calculate water quality volume (Acre-Feet):

$$WQV = \text{Area} \times \text{Maximized Detention Volume } (P_0)$$

Obtain A from Step 1

A

hrs

Specified Draw Down time

Obtain  $P_0$ : Maximized Detention Volume from figures E-1 to E-4 in Appendix E of this manual using  $I_A$  from Step 2.

$P_0$

Calculate treatment volume (acre-ft):

$$\text{Treatment volume} = A \times (P_0 / 12)$$

Acre-Feet

v06232012

Sacramento 5 ESE (7633) - Sacramento County, California  
Capture / Treatment Analysis

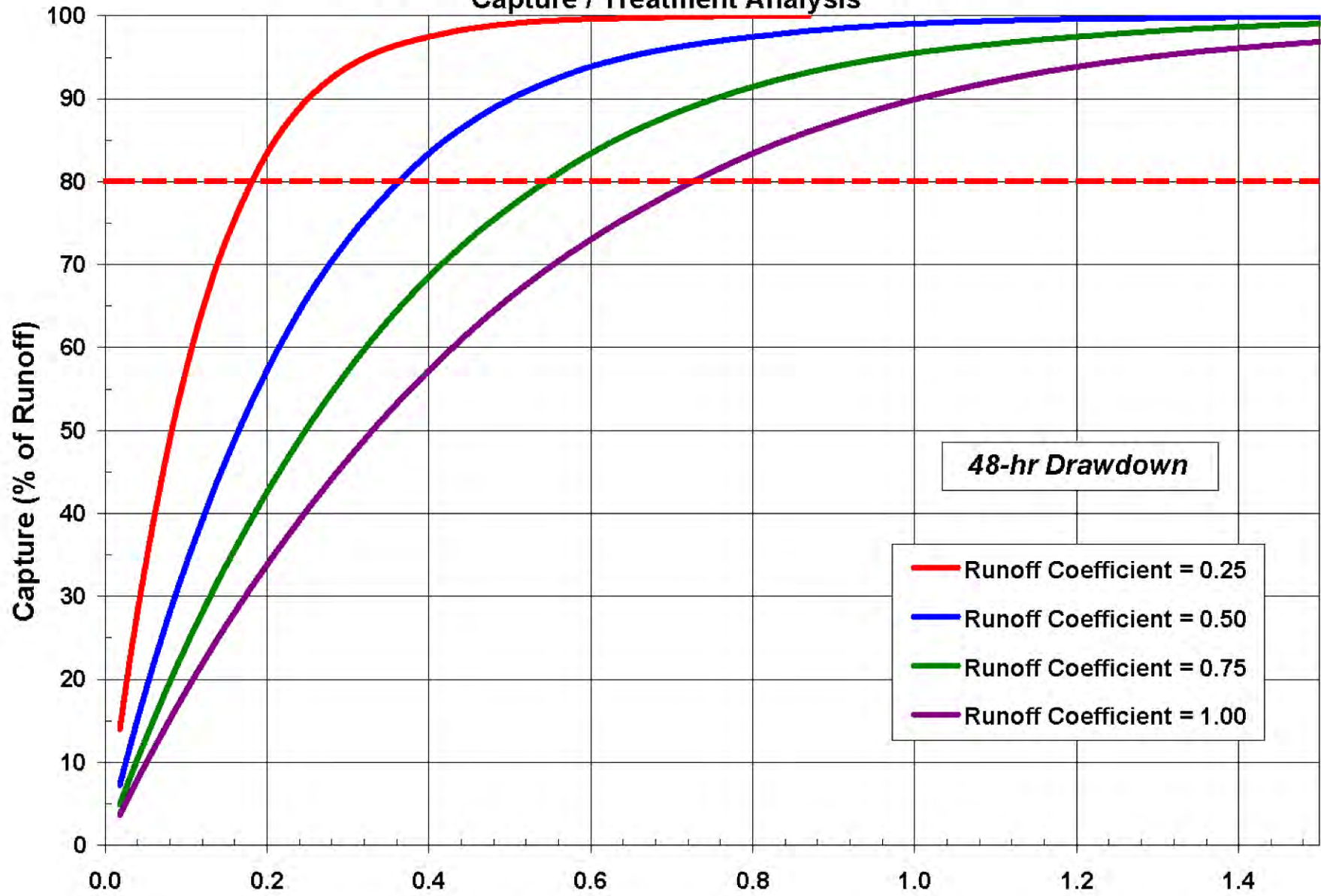

Figure D-2A. Unit Basin Storage Volume (inches)

## Appendix D-3 Runoff Reduction Credit Criteria

The following series of tables presents information related to calculating runoff reduction credits for the control measures presented in Chapter 5 of the Design Manual.

### Runoff Reduction Credits for Porous Pavement

This table refers to runoff reduction credit worksheets/forms which can be found in Appendix D-1 and D-2 of this Design Manual. Efficiency multipliers were taken from Denver manual.

Pavement Type	Applications and Runoff Reduction Credits
Pervious Concrete or Asphalt	Residential – Runoff Reduction Credits can be obtained for use of these materials in driveways (see Alternative Driveways Fact Sheet). The credit calculation is simplified in Appendix D-1.
	Commercial – Runoff Reduction Credits can be obtained for the use on any appropriate commercial surface. Credits are calculated using an efficiency multiplier of 60%. The credit calculation is simplified in Appendix D-2.
Modular Block Pavement	Residential – Runoff Reduction Credits can be obtained for use of modular block in driveways (see Alternative Driveways Fact Sheet). The credit calculation is simplified in Appendix D-1. Credits can be obtained for use of modular block in other areas of residential development where surfaces which would otherwise be impervious are substituted with MBP. Use an efficiency multiplier of 75%.
	Commercial – Runoff Reduction Credits can be obtained for the use of modular block on any appropriate commercial surface. Credits are calculated using an efficiency multiplier of 75%. The credit calculation is simplified in Appendix D-2.
Reinforced Grass Pavement	Residential – Runoff Reduction Credits can be obtained for use of reinforced grass pavement in residential development where surfaces which would otherwise be impervious are substituted with reinforced grass pavement. Use an efficiency multiplier of 100%.
	Commercial – Runoff Reduction Credits can be obtained for the use of reinforced grass pavement on any appropriate commercial surface. Credits are calculated using an efficiency multiplier of 100%. This calculation is simplified in Appendix D-2.
Cobblestone Block Pavement	Residential – Runoff Reduction Credits can be obtained for use of cobblestone block pavement in driveways (see Alternative Driveways Fact Sheet). The credit calculation is simplified in Appendix D-1. Credits can be obtained for use of cobblestone block pavement in other areas of residential development where surfaces which would otherwise be impervious are substituted with cobblestone block pavement. Use an efficiency multiplier of 40%.
	Commercial – Runoff Reduction Credits can be obtained for the use of cobblestone block pavement on any appropriate commercial surface. Credits are calculated using an efficiency multiplier of 40%. This calculation is simplified in Appendix D-2.

Pavement Type	Applications and Runoff Reduction Credits
Porous Gravel Pavement	Residential – Runoff Reduction Credits can be obtained for use of porous gravel pavement in residential development where surfaces which would otherwise be impervious are substituted with porous gravel pavement. Use an efficiency multiplier of 75%.
	Commercial – Runoff Reduction Credits can be obtained for the use of porous gravel pavement on any appropriate commercial surface. Credits are calculated using an efficiency multiplier of 75%. This calculation is simplified in Appendix D-2.

## Runoff Reduction Credits for Disconnected Pavement

Efficiency multipliers were taken from Denver manual.

Variation/Application	Runoff Reduction Credits										
<b>Pavement Draining to Landscaping</b>											
Residential	Runoff Reduction Credits can be obtained for disconnection of sidewalks (simplified in Appendix D-1, Form D-1b) and driveways (see Alternative Driveways Fact Sheet, simplified in Form D-1d).										
Commercial	Runoff Reduction Credits can be obtained for use of landscaping to disconnect impervious surfaces. Credit can apply to 100% of up to 1000 square feet of pavement draining to each properly designed vegetated area. (Source: Contra Costa Clean Water Program)										
<b>Pavement Draining to Porous Pavement (Source: Denver)</b>											
Commercial	<p>Runoff Reduction Credits can be obtained for disconnected impervious surfaces with the amount of credit dependent on the ratio of impervious surfaces to pervious surfaces. More credit is given for lower ratios. If the impervious surface area equals no more than half the area of the porous surface, then credit is given for the entire impervious surface. As the ratio increases above 0.5, the treatment provided is decreased resulting in a lower infiltration factor. Credit is not given for ratios above 2.0. Credit allowed for specific impervious/pervious ratios are listed below:</p> <table border="1" data-bbox="570 1451 1240 1793"> <thead> <tr> <th>Impervious Area/Porous Area Ratio</th> <th>Efficiency Multiplier</th> </tr> </thead> <tbody> <tr> <td>≤ 0.5</td> <td>1.00</td> </tr> <tr> <td>0.5 – 1.0</td> <td>0.83</td> </tr> <tr> <td>1.0 – 1.5</td> <td>0.71</td> </tr> <tr> <td>1.5 – 2.0</td> <td>0.55</td> </tr> </tbody> </table> <p>The efficiency of the porous pavement in infiltrating sheet flow is dependent on the type of pavement used. The following are the efficiency factors for different</p>	Impervious Area/Porous Area Ratio	Efficiency Multiplier	≤ 0.5	1.00	0.5 – 1.0	0.83	1.0 – 1.5	0.71	1.5 – 2.0	0.55
Impervious Area/Porous Area Ratio	Efficiency Multiplier										
≤ 0.5	1.00										
0.5 – 1.0	0.83										
1.0 – 1.5	0.71										
1.5 – 2.0	0.55										

Variation/Application	Runoff Reduction Credits												
	pavement types: <table border="1" style="margin-left: 40px;"> <thead> <tr> <th>Porous Pavement Type</th> <th>Efficiency Multiplier</th> </tr> </thead> <tbody> <tr> <td>Modular Block Pavement</td> <td>0.75</td> </tr> <tr> <td>Cobblestone Block Pavement</td> <td>0.40</td> </tr> <tr> <td>Reinforced Grass Pavement</td> <td>1.00</td> </tr> <tr> <td>Poured Porous Concrete Pavement</td> <td>0.60</td> </tr> <tr> <td>Porous Gravel Pavement</td> <td>0.75</td> </tr> </tbody> </table>	Porous Pavement Type	Efficiency Multiplier	Modular Block Pavement	0.75	Cobblestone Block Pavement	0.40	Reinforced Grass Pavement	1.00	Poured Porous Concrete Pavement	0.60	Porous Gravel Pavement	0.75
Porous Pavement Type	Efficiency Multiplier												
Modular Block Pavement	0.75												
Cobblestone Block Pavement	0.40												
Reinforced Grass Pavement	1.00												
Poured Porous Concrete Pavement	0.60												
Porous Gravel Pavement	0.75												

These tables refer to runoff reduction credit worksheets/forms which can be found in Appendix D-1 and D-2 of this Design Manual.

### Runoff Reduction Credits for Alternative Driveways

Variation	Applications and Runoff Reduction Credits
Pervious Driveway	Residential – credits can be applied for the entire driveway surface when approved materials and specifications are used in accordance with the Design Requirements. Use Appendix D-1.
Hollywood Driveway	Residential – an efficiency multiplier of 75% of the driveway area when approved materials and specifications are used in accordance with the Design Requirements. Use Appendix D-1.
Disconnected Driveway	Residential – credits can be for the entire driveway surface when designed according to this fact sheet. Use Appendix D-1.
Shared Driveway	Residential – credits vary according to design. Consult municipal engineer.

### Runoff Reduction Credits for Disconnected Roof Drains

Variation	Applications and Runoff Reduction Credits
<b>Splash Block/Pop-up Drainage Emitter</b>	
Residential	Credit may be given for each disconnected roof drain with the amount of credit dependent upon building set back. This calculation is simplified in Appendix D-1.
Commercial	Credit may be given for each disconnected roof drain meeting the design requirements. The credit calculation is simplified in Appendix D-2.
<b>Dispersal Trench and Dry Well</b>	
Residential	Credit may be given for each disconnected roof drain meeting the design

Variation	Applications and Runoff Reduction Credits
	requirements. The credit calculation is simplified in Appendix D-1.
Commercial	Credit may be given for each disconnected roof drain meeting the design requirements. The credit calculation is simplified in Appendix D-2.

## Runoff Reduction Credits for Interceptor Trees

Variation	Applications and Runoff Reduction Credits
All Planted Trees	Residential - Credit may be given for each new tree planted in the municipal right-of-way. Consult municipality about the possibility of credits for trees outside of the municipal right-of-way. This calculation is simplified in Appendix D-1.
	Commercial - Credit may be given for each new tree planted within 25 feet of ground level impervious surfaces. 25% of trees already required by zoning can be used for Interceptor Tree credits. This calculation is simplified in Appendix D-2.
New Evergreen Trees	20 square feet of credit
New Deciduous Trees	100 square feet of credit
Existing Trees	The Runoff Reduction Credit, as applied to existing trees, is calculated by identifying the square-footage equal to one-half of the existing tree canopy, measured within the drip line. The resulting square footage divided by the total site square footage is equal to the IRP. This calculation is simplified in Appendix D-1 and D-2.
*Trees required by the municipality as mitigation for other trees lost on the project will not count toward Runoff Reduction Credit.	

## Trees Qualifying for Interceptor Tree Runoff Reduction Credits\*

Common Name	Botanical Name	Type**	Mature Tree		
			Shape	Canopy (dia.)	Height (max.)
American Chestnut	<i>Castanea dentate</i>		Oval to rounded or wide spreading	40-60'	80-120'
American Hornbeam	<i>Carpinus caroliniana</i>		Vase-shaped	20-30'	25-30'
American Linden	<i>Tilia americana</i>		Oval and informal	30-60'	60-80' (100')
American Sweet Gum	<i>Liquidambar styraciflua</i>		Conical	20-40'	45-65'
Amur Maackia	<i>Maackia amurensis</i>		Vase-shaped	15-20'	20-30'
Amur Maple	<i>Acer tataricum ginnala</i>		Rounded	15-20'	20'
Arizona Cypress	<i>Cupressus arizonica</i>	E	Conical to vase	25-30'	40-50'
Atlas (Blue) Cedar	<i>Cedrus atlantica</i>	E	Flat-topped,	30-40'	40-60' (120')

Common Name	Botanical Name	Type**	Mature Tree		
			Shape	Canopy (dia.)	Height (max.)
			loose, open and spreading		
Autumn Blaze Maple	<i>Acer fremanii</i> 'Autumn Blaze'		Oval	50'	50'
Bald Cypress	<i>Taxodium distichum</i>		Oval at maturity, uniform	20-30'	50-70' (100')
Bechtel Crabapple	<i>Malus ioensis</i> 'Plena'		Broad-rounded	20'	25'
Bigleaf Maple	<i>Acer macrophyllum</i>	N	Broad-rounded	30-75'	45-75' (100')
Blue Oak	<i>Quercus douglasii</i>	N P	Rounded umbrella	50-80'	50-60'
Burr Oak	<i>Quercus macrocarpa</i>		Broad-rounded	75-85'	70-80'
California Bay	<i>Umbellularia californica</i>	EN	Round	30'	25'
California Black Oak <sup>a</sup>	<i>Quercus kelloggii</i>	N	Vase	30-60'	30-80'
Callery Pear	<i>Pyrus calleryana</i>		Columnar, Oval, Round	25'	40'
Canary Island Date Palm	<i>Phoenix canariensis</i>	E	Round head	25-30'	60'
Canary Island Pine	<i>Pinus canariensis</i>	E	Pyramidal	25-35'	60-80'
Canyon Live Oak	<i>Quercus chrysolepis</i>	E N	Broad-rounded	50-70'	50-75'
Carob	<i>Ceratonia siliqua</i>	E	Broad to wide-rounded	30-45'	30-40'
Carolina Laurel Cherry	<i>Prunus caroliniana</i>	E	Irregular rounded	15-25'	20-30' (40')
Chaste Tree	<i>Vitex agnus-castus</i>		Rounded	15-20'	20-25'
Chestnut-Leafed Oak	<i>Quercus castaneafolia</i>		Broad and rounded	50-60'	70-90'
Chinese Evergreen Elm	<i>Ulmus parvifolia</i>		Rounded	40-50'	40-50' (70')
Chinese Fringe Tree	<i>Chionanthus retusus</i>		Rounded	20-25'	20-25'
Chinese Hackberry	<i>Celtis sinensis</i>		Rounded	50-60'	40-80'
Chinese Pistache	<i>Pistacia chinensis</i>		Broad-rounded	25-35'	30-35' (50')
Chinese Wingnut	<i>Pterocarya stenoptera</i>		Broad-rounded	30-40'	40-90'
Coast Live Oak	<i>Quercus agrifolia</i>	EN	Rounded	60'	40'
Coast Redwood	<i>Sequoia sempervirens</i>	E	Narrow pyramidal to wide conical	50-60'	200-300'
Colorado Spruce	<i>Picea pungens</i>	E	Narrow pyramidal to broad conical	10-20'	30-60' (135')
Common Horsechestnut	<i>Aesculus hippocastanum</i>		Pyramidal to oval	40-70'	50-75' (100'+)

Common Name	Botanical Name	Type**	Mature Tree		
			Shape	Canopy (dia.)	Height (max.)
Coolibah	<i>Eucalyptus microtheca</i>		Round head	30'	25-50'
Cork Oak	<i>Quercus suber</i>	E	Rounded	35-45'	70-100'
Crabapple 'Prariefire'	<i>Malus ioensis</i> 'Prariefire'		Broad-rounded	15-20'	25'
Crape Myrtle (Tree Form, some are large shrubs)	<i>Lagerstroemia hybrids</i>		Broad-rounded	15-20'	15-30'
Crimson Sentry Maple	<i>Acer platanoides</i> 'Crimson Sentry'		Oval	40'	40'
Dawn Redwood	<i>Metasequoia glyptostroboides</i>		Conical to narrow pyramidal and formal	25-35'	80-90' (120')
Deodar Cedar	<i>Cedrus deodara</i>	E	Wide and slightly flat-topped	30-60'	40-70' (200')
Douglas Fir	<i>Pseudotsuga menziesii</i>	E N	Broadly cylindrical	30-40'	40-80' (200')
Eastern Dogwood	<i>Cornus florida</i>		Broad-rounded	15-20'	20-25'
Eastern Redbud	<i>Cercis canadensis</i>		Rounded	25-35'	20-30'
English Hawthord 'Paul's Scarlet'	<i>Crataegus laevigata</i> 'Paul's Scarlet'		Vase-shape	20-25'	18-25'
English Oak	<i>Quercus robur</i>			50'	50'
European Beech	<i>Fagus sylvatica</i>		Oval to rounded	35-45'	50-60' (100')
European Hackberry	<i>Celtis australis</i>		Rounded	50-60'	40-80'
European Hornbeam	<i>Carpinus betulus</i> 'Fastigiata'		Broad oval-vase shaped	20-30'	40'
Evergreen Ash	<i>Fraxinus uhdei</i>	E	Round head	70'	40'
Flannel Bush	<i>Fremontodendron californicum</i>	E	Flat-topped Vase	20-25'	20-25'
Forest Green Oak	<i>Quercus frainetto</i> 'Forest Green'		Rounded	30'	50'
Formosan Flame	<i>Koelreuteria elegans</i>		Broad rounded	35'	35'
Fragrant Snowbell	<i>Styrax obassia</i>		Rounded	15-20'	20-30'
Frontier Elm	<i>Ulmus 'Frontier'</i>			30'	40'
Ginkgo Biloba (Male Only)	<i>Ginkgo biloba</i>		Wide rounded-pyramidal	30-40'+	35-80' (100')
Golden Flame Tree	<i>Koelreuteria bipinnata</i>		Rounded	15-25'	20-40'
Goldenchain Tree	<i>Laburnum anagyroides</i>		Oval to round-headed	15-20'	20-30'
Goldenrain Tree	<i>Koelreuteria paniculata</i>		Rounded	30-40'+	30-40'
Grecian Laurel	<i>Laurus nobilis</i>	E	Irregular rounded	20-25'	15-40'
Green Ash	<i>Fraxinus pennsylvanica</i> 'Patmore', 'Leprichau'		Oval, irregular	30'	40'



Common Name	Botanical Name	Type**	Mature Tree		
			Shape	Canopy (dia.)	Height (max.)
	'Centerpoint'				
Hedge Maple	<i>Acer campestre</i>		Rounded	30-35'	30-70'
Holly Oak	<i>Quercus ilex</i>	E	Rounded	40-50'	40-70'
Honey Locust (thornless)	<i>Gleditsia triacanthos</i>		Rounded to wide-rounded	30-70'	35-70'
Incense Cedar	<i>Calocedrus decurrens</i>	E N	Conical	25-30'	30-50' (150')
Interior Live Oak	<i>Quercus wislizenii</i>	E N P	Irregular	30-60'	30-75'
Italian Stone Pine	<i>Pinus pinea</i>		Broad, flat topped	30-40'	40-80'
Japanese Maple	<i>Acer palmatum</i>		Broad-rounded	25'+	20'
Japanese Pagoda Tree	<i>Sophora japonica</i>		Rounded to broad-spreading	50-75'	50-75'
Japanese Red Pine	<i>Pinus densiflora</i>	E	Broad-pyramidal and irregular	40-60'	40-60' (100')
Japanese Snowdrop	<i>Styrax japonicus</i>		Rounded	15-20'	25-30'
Japanese White Birch	<i>Betula platyphylla japonica</i>		Oval	20-25'	40-50'
Jelescote Pine	<i>Pinu patula</i>	E		25'	30'
Kentucky Coffee Tree	<i>Gymnocladus dioica</i>		Oval with coarse branching	40-50'	60-75' (90')
Kobus Magnolia	<i>Magnloia kobus</i>		Rounded	15-25'	30'
Little-Leaf Linden	<i>Tilia cordata</i>		Rounded pyramidal	30-50'	60-70' (90')
Mexican Fan Palm	<i>Washingtonia robusta</i>	E	Round head	10-15'	100'
Norwegian Sunset Maple	<i>Acer truncatum</i> 'Norwegian Sunset'			25'	30'
Pin Oak	<i>Quercus palustris</i>		Uniformly pyramidal with a straight central leader	25-40'	50-80'
Ponderosa Pine	<i>Pinus ponderosa</i>	E N	Conical	30-50'	60-100' (230')
Prospector Elm	<i>Ulmus 'Prospector'</i>			30'	40'
Purple Leaf Plum	<i>Prunus cerasifera</i> 'Krauter Vesuvius'		Rounded	15-25'	15-30'
Red Maple	<i>Acer rubrum</i>		Oval to rounded	To 60'	40-60' (120')
Red Oak	<i>Quercus rubra</i>		Rounded	60-75'	60-75' (100')
Saucer Magnolia	<i>Magnloia x soulangeana</i>		Rounded	20-30'	25'
Scarlet Oak	<i>Quercus coccinea</i>		Oval to rounded with an open habit	40-50'	70-75' (100')
She-oak	<i>Casuarina stricta</i>	E	Oval/vase	15-25'	20-35'
Shumard Red Oak	<i>Quercus shumardii</i>		Oval	50'	70'

Common Name	Botanical Name	Type**	Mature Tree		
			Shape	Canopy (dia.)	Height (max.)
'Seville' sour orange	<i>Citrus 'Seville'</i>	E	Rounded	15-20'	20-30'
Southern Live Oak	<i>Quercus virginiana</i>	E	Broad rounded, irregular	65'	60'
Southern Magnolia	<i>Magnolia grandiflora</i>	E	Broad pyramidal, rounded pyramidal and rounded	30-50'	60-80'
Southern Magnolia 'St. Mary'	<i>Magnolia grandiflora 'St. Mary'</i>	E	Rounded	15-20'	20'
Strawberry Tree	<i>Arbutus unedo</i>	E	Oval to rounded	15-35'	15-35'
Sugar Maple	<i>Acer saccharum</i>		Oval to rounded	40-60'	60-75' (120')
Sycamore	<i>Platanus species</i>	S	Oval to rounded	30-50'	40-100'
Texas Red Oak	<i>Quercus buckleyi</i>			25'	30'
Trident Maple	<i>Acer buergerianum</i>		Oval	20-25'	20-25'
Tulip Tree	<i>Liriodendron tulipifera</i>		Oval-rounded with a strong central leader	35-50'	70-90' (150')
Tupelo / Sour Gum	<i>Nyssa sylvatica</i>		Rounded pyramidal	20-30'	30-50'
Valley Oak	<i>Quercus lobata</i>	N P	Broad-rounded	50-80'	70'+
Vine Maple	<i>Acer circinatum</i>	N	Rounded	25-35'	5-35'
Washington Hawthorn	<i>Crataegus phaenopyrum</i>		Rounded, vase-shaped	15-20'	25'
Western Red Cedar	<i>Thuja plicata</i>	E	Conical to wide conical	50-80'	50-70' (200')
Western Redbud	<i>Cercis occidentalis</i>		Rounded	10-18'	10-18'
White Alder	<i>Alnus rhombifolia</i>	N	Pyramidal to rounded	15-25'	30-45'
White Ash	<i>Fraxinus Americana 'Autum Purple', 'Chicago Regal'</i>		Oval	60'	40'
Willow Oak	<i>Quercus phellos</i>		Rounded	30-40'	40-60' (100')
Zelkova	<i>Zelkova serrate</i>		Vase-shaped and rounded	30-60'	50-80' (120')

\*proposed tree's/landscaping plans are subject to the approval of the local permitting agency

<sup>a</sup>only allowed in foothills of Folsom

\*\*E = Evergreen; N = Native; P = Protected Species (may vary by jurisdiction); S = Some Can Be Native

# Appendix D-4 LID Credits Background Report

---

## I. Introduction

Multiple environmental agencies, including the Central Valley Regional Water Quality Control Board, have recently adopted a strategy to encourage municipalities and developers to incorporate Low Impact Development (LID) into site planning and design. Low Impact Development includes a set of measures that reduce site imperviousness, thereby reducing storm water runoff, and/or provide filtration through vegetation or infiltration. In theory, use of LID controls within a given site results in a reduction of the amount of storm water requiring treatment, termed Runoff Reduction. The purpose of this report is to summarize an effort undertaken by local agencies to develop an LID, or Runoff Reduction, credit system. This system is being developed for use in the Stormwater Quality Design Manual for the Sacramento Region (Manual).

The NPDES Phase I and Phase II Municipal Stormwater Permits for the County of Sacramento (and copermittees) and the City of Roseville, respectively, require that treatment of storm water occur for development projects of various types: residential and commercial being the most common. Thresholds (by size of development) for treatment vary by permit, but all participating municipalities have an interest in achieving regional consistency in the application of storm water design standards.

This document and the resulting worksheets are an attempt to 1) quantify the benefit obtained through the incorporation of specific Runoff Reduction measures, and 2) provide a mechanism by which developers can calculate the benefit for using Runoff Reduction and the resulting reduction in size of treatment controls. This is achieved by assigning “credits” to the use of Runoff Reduction measures.

This document focuses on the two most common types of development, residential and commercial, but the concepts presented could be easily adapted to other types of development projects.

### Assumptions

The Runoff Reduction credit system has been developed based on the following assumptions.

- Pavement/asphalt and roof tops are 100% impervious.
- Landscaped areas, lawns, and natural areas are pervious and any runoff generated from these areas is assumed to be clean with no further treatment needed.
- Runoff from porous pavements is partially infiltrated/reduced depending on how pervious the material is and on the permeability of native soils.
- Runoff from impervious surfaces that flows across pervious surfaces is partially reduced with the amount of reduction dependent on the type of receiving surface.

## II. Residential Credits Calculation

### Background Data

Research was conducted in 2005 by the City of Roseville and the County of Sacramento using studies of available maps of residential developments of various sizes and types within Sacramento and Placer County. These maps were used to calculate the aggregate area of features of interest: streets, rooftops, sidewalks, and driveways, as well as the total area of each development. A value was calculated for rooftops, sidewalks, driveways, streets, and total impervious surface as a percentage of the total area. This information was compiled to obtain local, accurate, empirical values for the average impervious fraction of different types of residential developments with differing densities (dwelling units per acre), as well as information about how the different features contribute to total site imperviousness. Data collected in the research effort for 29 sites is summarized in Attachment A.

The Sacramento/Roseville data was used to compute an average impervious fraction for each of eight categories of residential development classified by density, which ranged from one dwelling unit per acre to 20 dwelling units per acre. Average total impervious fraction and percent imperviousness by surface type has been identified in Table 1.

Table 1 Average Impervious Fraction by Surface Type for Eight Categories of Residential Development

Density in Dwelling Unites per acre (DU/A)	1	2	3-4	5-6	7	8-9	10-14	15-20
Total Impervious Fraction	0.17	0.25	0.35	0.40	0.50	0.55	0.60	0.70
Rooftop	0.08	0.13	0.19	0.23	0.29	0.33	0.37	0.44
Sidewalk	0.04	0.04	0.04	0.04	0.04	0.04	0.04	0.04
Driveway	0.04	0.04	0.04	0.04	0.04	0.04	0.04	0.04
Street	0.01	0.04	0.08	0.09	0.13	0.14	0.15	0.18

### Appendix D-1 in Manual

The Residential Runoff Reduction Worksheet, Form D-1, allows a designer to calculate a reduced treatment requirement based on the incorporation of various Runoff Reduction measures into their project. To use Appendix D-1, the designer must obtain an accurate estimate of the project area, then estimate how much of that area will be ‘open space and parks’ as defined in the Manual. Open space and parks does not include landscaping within individual residential lots. The open space/parks acreage is subtracted from the total acreage to find the size of the area that will require treatment, At. These calculations are completed in Step 1 of the form.

The designer then proceeds through Step 2 to determine how much credit is earned for Runoff Reduction techniques incorporated into the project. Using predetermined impervious fraction factors and Forms D-1a-d, the designer calculates the size of each area that will be affected by various Runoff Reduction techniques, and these areas become “effectively managed” under the

system. The total Effective Area Managed (Ac) equals the amount of credit allowed for the incorporation of Runoff Reduction measures.

For every technique, an *efficiency multiplier* is provided which reflects the fraction of runoff that is being reduced or treated from the area being considered. For example, a porous pavement driveway reduces runoff from the driveway by 60% while a Hollywood driveway reduces runoff by 75%, based on each driveway's ability to infiltrate stormwater. After an efficiency multiplier is determined, a *use multiplier* representing the percentage of units in the development that are using the technique is determined. So, if 50% of the units in the development use the Runoff Reduction measure, then 50% of possible reduction is achieved. Finally, a *reduction factor* is selected, which represents the fraction of land that the surface of interest represents. For example, in calculating the amount of credits allowed for an alternative driveway, the reduction factor reflects the area of driveway surface as a fraction of the total area requiring treatment (At); in all residential developments, driveways comprise 4% of the total area. These fractions are all multiplied together to get a fraction of total site area effectively managed. This is multiplied by the total acreage of AT to find the area of impervious surface that is effectively managed (Ac) by using the Runoff Reduction technique.

So the *effective area managed* is equal to:

$$\text{efficiency multiplier} * \text{use multiplier} * \text{reduction factor} * \text{total acreage}$$

Runoff Reduction measures for which credit can be obtained within residential development projects include *disconnected roof drains, disconnected pavement, interceptor trees, and alternative driveways*. All Runoff Reduction measures must be designed and installed in accordance with specifications and details provided in Fact Sheets included in the Manual. The basis for the credit allowed for each of the Runoff Reduction measures has been detailed below.

#### *Disconnected Roof Drains (DRDs)*

Disconnected roof drains (DRDs) can achieve the functional equivalent of reducing a large amount of imperviousness by directing rooftop runoff to a pervious surface, dispersal trench, or dry well, as allowed by the local permitting agency. Use of DRDs as a Runoff Reduction measure has been recommended in guidance manuals such as *Start at the Source* (1999) and *The Practice of Low Impact Development* (2003.) If the roof drainage is connected to a dispersal trench or a dry well that have been designed according to specifications provided in the fact sheet, then 100% of the impervious surface attributed to rooftop is considered treated for that unit, thus the *efficiency multiplier* is 1.00. Design standards for the dispersal trench and dry well are adapted from *High Point Community Site Drainage Technical Standards* (2004) and *Virginia Stormwater Management Program Handbook* (1999).

If the runoff, via the roof drain, is directed across the surface of the landscaping, then the amount of runoff that will be treated is dependent on the amount of vegetation the water will flow through before entering the storm drain system. The design specifications for Sacramento County require a 20-foot setback between the house and the sidewalk. Most new developments obtain variances to reduce their setback distances to 15 feet or 12.5 feet. The *efficiency multiplier* for disconnected roof drains draining to landscaping is then found using manning's equation to solve for hydraulic

residence time. The Manning's equation used is the equation described in *Filter Strip Worksheet 2005 Surface Water Design Manual Sizing Method* published in the King County Surface Water Design Manual published by King County Water and Land Resources Division.

$$L = t \frac{Q}{W} \left( \frac{1.49W\sqrt{s}}{Qn} \right)^{0.6}$$

Where

L = filter strip length (feet)

t = hydraulic residence time (seconds)

Q = design flow (cfs)

W = filter strip width (feet)

n = Manning's roughness coefficient

s = longitudinal slope along path

$$WQF = C i A$$

Where

WQF = design flow (cfs)

C = Rational Runoff coefficient

i = rainfall intensity (in/hr)

A = Area (acres)

The equation is solved for hydraulic residence time, using various setback lengths and the following assumptions:

#### Residential Disconnected Roof Drain Assumptions

W = 5 feet (recommended by local hydrologist as typical average)

s = 0.01

n = 0.35 (residential is likely to have short grasses)

C = 0.9 (rational C) (corresponds to rooftop's 100% imperviousness)

Rooftop area = 2,500 sq feet (average roof area for 5-7 DU/A)

The hydraulic residence time is then computed as a percentage of the value for full treatment, identified as being 7 minutes by many stormwater manuals. The results are summarized in Table 2, and multipliers are rounded to the nearest 0.05 in the form.

Table 2 DRD Efficiency Multipliers Based on Length of Front Yard Setback

Length of Setback (feet)	Residence Time (min)	Percent of 7 minutes	Efficiency Multiplier
25	8.6	123%	1
20	6.9	98%	0.98
15	5.2	74%	0.74
10	3.4	48%	0.48
5	1.7	24%	0.24

The designer must determine how many of the roof downspouts are to be disconnected, as a percentage of total roof downspouts. This determines the *use multiplier* for disconnected rooftops.

The form is used to determine the area of impervious surface accounted for by rooftops, dependent on site density (1-20 DU/A). This area is the maximum amount of impervious surface that can be effectively managed with DRDs and comprises the *reduction factor*. Reduction factors for DRDs range from 0.08 to 0.44 and are summarized in Table 1.

*Example:*

If a 20-acre residential site, 5 DU/A (23% rooftop impervious surface), includes the disconnection of all roof drains on 40% of houses with a setback of 12 feet (48% treatment) the Runoff Reduction measure would result in:

$$(0.48)(0.40)(0.23)(20 \text{ acres}) = 0.044(20 \text{ acres}) = 0.88 \text{ acres of effectively managed area (Ac).}$$

*Divided Sidewalks (DS)*

Divided Sidewalks (DS) function to drain water runoff from sidewalks onto a strip of grass located between the sidewalk and the street. Divided Sidewalks are essentially a variation on Disconnected Pavement (DP) and the credits application method for DP was adapted from the *Urban Storm Drainage Criteria Manual Volume 3 – Best Management Practices for Denver (2005)*. The landscaping strips are usually as wide as the sidewalks themselves, so the sidewalks are considered entirely treated. Sidewalks account for approximately 6% of the total area of most residential developments, so if all units use divided sidewalks the development will treat 6% of total site runoff. If a development chooses to use divided sidewalks on some areas, connector streets for example, the amount of credits applied will be scaled by the percentage of units using the design. A designer chooses the percentage of units using the design, and the number is multiplied by 0.04 to get the total credits obtained.

If a designer uses divided sidewalks on 30% of units in a 200 acre development, the credit allowed:  
use multiplier \* reduction factor \* total acreage

$$(0.30)(0.04)(200 \text{ acres}) = 0.012(200 \text{ acres}) = 2.4 \text{ acres of effectively managed area (Ac)}.$$

#### *Interceptor Trees (IT)*

Interceptor trees can prevent and/or delay water from landing on an impervious surface. Much of the intercepted water runs down along the tree's leaves and branches and evaporates, or runs down into the root system. Properly located trees can reduce the effective impervious fraction by diverting rain that would otherwise fall on streets and sidewalks. The *City of Portland Stormwater Management Manual* (2004) and City of San Jose policy apply 100 sq. feet of credit for a deciduous tree and 200 sq. feet for an evergreen tree. Research results published by Q. Xiao (1998, 2000(2), 2003) provides evidence that this credit system is appropriate for the central valley climate. The number of trees is multiplied by the credit to obtain an area reduced by interceptor trees. Credits may be applied for existing trees as defined in Interceptor Trees Fact Sheet. To calculate the credits allowed for existing interceptor trees, the designer must identify the square footage equal to one half of the existing tree canopy. The resulting area is considered the area effectively managed by the existing interceptor trees.

#### *Alternative Driveway Design (ADD)*

Alternative driveways can be designed to incorporate a pervious or semi-pervious surface or to direct runoff into vegetation. Use of ADD as a Runoff Reduction measure has been recommended in guidance manuals such as *Start at the Source* (1999) and *The Practice of Low Impact Development* (2003.) The amount of runoff infiltrated on driveways depends on the type of porous pavement used (acceptable types of porous pavements are listed under the Porous Pavement Section), therefore *efficiency factors* vary from 0.40 to 1.00 (see below **Porous Pavement**). For Hollywood driveways, which reduce pavement area but do not necessarily utilize alternative pavement types, the reduction of paved surface and the redirection of stormwater into the unpaved section results in an *efficiency factor* of 0.75.

The designer must determine how many of the driveways are to be designed using the alternative method, as a percentage of total driveways. This determines the *use multiplier* for ADD. Reduction factor for ADD measures for all development densities are 0.04, as summarized in Table 1.

#### *Example:*

If 50% of the homes in a 100 acre residential site, 5 DU/A (4% driveway impervious surface), use Hollywood driveways, the Runoff Reduction measure would result in:

$$(0.50)(0.04)(0.75)(100 \text{ acres}) = 0.015(100 \text{ acres}) = 1.5 \text{ acres of effectively managed area (Ac)}.$$

Using the Effective Area Managed (Ac) in Calculating Treatment Requirement  
After each Runoff Reduction measure has been addressed on the subforms, Forms D-1a through D-1d, the  $A_c$  is totaled. This managed area is subtracted from the Area Requiring Treatment ( $A_T$ ) found



in Step 1. The Adjusted Area Requiring Treatment ( $A_{AT}$ ) is also used to find an Adjusted Impervious Fraction ( $I_A$ ).

After the  $A_{AT}$  is calculated, the water quality flow and/or volume must be calculated for sizing treatment controls. Whether the designer needs to calculate flow-based treatment or volume-based treatment depends on the type of treatment planned.

Treatment flow (WQF) is found using the standard flow equation,

$$WQF = C i A$$

where  $C$  is the rational runoff coefficient based on the DU/A (Table D-1b in Form D-1),  $i$  is the rainfall intensity (varies by region, see Table D-1c in Form D-1), and  $A$  is the adjusted area requiring treatment ( $A_{AT}$ ). This value is to be used when determining sizing criteria for structural treatment controls.

Treatment Volume is found using either the CASQA method (Roseville):

$$V = A \times SV / 12$$

where  $A$  = the total area of the drainage shed,  $SV$  = the Unit Basin Storage Volume; use  $C_A$  adjusted for credits earned (see Adjusted Runoff Coefficient, below).

Or the ASCE-WEF method (Sacramento):

$$WQV \text{ (ac-ft)} = P_o * A / 12$$

where  $A$  = the total area of the drainage shed,  $P_o$  = maximized detention volume using the ASCE-WEF method.

Please refer to Chapter 5 and Appendix E for the selection of the treatment measures and design requirements. Then use form D-1f, Treatment – Volume Based (CASQA) for volume-based treatment controls within the City of Roseville, or form D-1g, Treatment – Volume Based, for treatment controls in areas outside of the City of Roseville.

#### Adjusted Runoff Coefficient

The Adjusted Impervious Fraction is converted to an Adjusted Runoff Coefficient,  $C_A$ , using the empirical regression equation presented in the California Stormwater BMP Handbook (CASQA, 2003).

$$C = 0.858 I^3 - 0.78 I^2 + 0.774 I + 0.04$$

where  $C$  = runoff coefficient,  $I$  = impervious fraction

The results of this equation for values of “ $I$ ” between 0 and 1 are listed in Table D-1d, Form D-1.

### III. Commercial and Multi-Family Credits Calculation

Appendix D-2 in Manual

The Commercial and Multifamily Runoff Reduction Worksheet, Appendix D-2, allows a designer to calculate a reduced treatment requirement based on the incorporation of various Runoff Reduction measures into their project. To use Appendix D-2, the designer must obtain an accurate estimate of the area, then estimate how much of that area will be ‘open space and parks’ as defined in the Manual. This includes all landscaping areas and areas left in a natural state. The open space acreage is subtracted from the total acreage to find the size of the area that will require treatment,  $A_T$ . This area ( $A_T$ ) generally includes parking lots, rooftops, and driveways, which are assumed to be impervious. The designer then calculates the size of each area that will be affected by various Runoff Reduction techniques, and these areas become “effectively managed” under the system. The total Effective Area Managed ( $A_c$ ) equals the amount of credit allowed for the incorporation of Runoff Reduction measures.

Runoff Reduction measures for which credit can be obtained within commercial and multi-family development projects include porous pavement, disconnected roof drains, green roofs, disconnected pavement, and interceptor trees. All Runoff Reduction measures must be designed and installed in accordance with specifications and details provided in Fact Sheets included in the Manual. The basis for the credit allowed for each of the Runoff Reduction measures has been detailed below.

#### *Porous Pavement*

The amount of credit applied for the use of porous pavement varies depending on the pavement type. The effective impervious fraction of these different types of porous pavement has been studied and reported in *Urban Storm Drainage Criteria Manual Volume 3 – Best Management Practices for Denver* (2005). This source was used to determine the impervious fraction of the following porous pavement types. Modular Block Pavement is concrete blocks with open voids occupying at least 20% of total surface area. The voids are filled with gravel and then filled in with sand. These surfaces have an effective impervious fraction of 25%, thus the *efficiency multiplier* is 0.75. Cobblestone Block Pavement consists of concrete blocks that look like cobblestone and create open voids between the blocks. These create an effective impervious fraction of 60%, and have an *efficiency multiplier* of 0.40. Reinforced Grass Pavement is a stabilized grass surface that infiltrates rainwater well. Because of this, it is given an *efficiency multiplier* of 1.00. Pervious Pavement is a concrete/asphalt that does not contain the normal fine sand and has 15-20% of its volume as void space. These are found to have an impervious fraction of 40%, and thus an *efficiency multiplier* of 0.60. Porous Gravel Pavement is a loose gravel paving and has an effective impervious fraction of 25%, and an *efficiency multiplier* of 0.75. The *efficiency multipliers* are listed in Table D-2a of Appendix D-2. For all pavement types, the *efficiency multiplier* is multiplied by the area of land utilizing the porous pavement type to determine total credits applied.

If Modular Block Pavement, which has an *efficiency multiplier* of 0.75, was used on 5,000 sq. ft of parking lot, the  $A_c$  would be:

$$5,000 * 0.75 = 3,750 \text{ square feet.}$$

*Disconnected Pavement (DP)*

Disconnected Pavement is pavement designed to allow stormwater to sheet flow over vegetated areas or porous pavement prior to entry into a storm drain system. The efficiency of this method depends on both the impervious fraction of the receiving porous surface, as well as the ratio of contributing area to receiving area. These two factors taken together allow for the calculation of an effective impervious fraction for the not directly connected surface. These values are derived from Figure PP-1 of the *Urban Storm Drainage Criteria Manual Volume 3 – Best Management Practices for Denver (2005)*. The designer begins by selecting the type of surface (landscaping or one of the porous pavements) that the disconnected pavement will run onto. If the pavement will be draining onto landscaping the entire pavement area is effectively treated, providing that the area draining onto the landscaping is not more than twice the area of landscaping.

If the pavement will be draining onto a porous pavement, first the ratio of contributing pavement to receiving pavement is calculated, then based on the resulting ratio, a multiplier is determined, as listed in Table 3. Porous pavement for which credit is obtained under Appendix D-2, Step 2, Porous Pavement Option, cannot be included in Disconnected Pavement calculations.

Table 3 Multipliers Based on Ratio of Contributing Pavement to Receiving Pavement

Ratio of Contributing Pavement to Receiving Pavement	Multiplier
<0.5	1.00
≥0.5 and <1.0	0.83
≥1.0 and <1.5	0.71
≥1.5 and <2.0	0.55

The efficiency multiplier for the selected porous pavement is selected from Table D-2a in Appendix D-2. The formula for calculating the  $A_c$  is as follows:

$$\begin{aligned}
 & (\text{area of receiving pavement})(\text{efficiency multiplier}) \\
 & + (\text{area of contributing pavement})(\text{ratio multiplier})(\text{efficiency multiplier}) = A_c
 \end{aligned}$$

*Disconnected Roof Drains (DRD)*

Disconnected roof drains (DRDs) can achieve the functional equivalent of reducing a large amount of imperviousness by directing rooftop runoff to a pervious surface, dispersal trench, or dry well. Use of DRDs as a Runoff Reduction measure has been recommended in guidance manuals such as *Start at the Source (1999)* and *The Practice of Low Impact Development (2003)*. If the roof drainage is connected to a dispersal trench or a dry well that have been designed according to specifications provided in the fact sheet, then 100% of the impervious surface attributed to rooftop is considered

treated for that unit, thus the *efficiency multiplier* is 1.00. Design standards for the dispersal trench and dry well are adapted from *High Point Community Site Drainage Technical Standards* (2004) and *Virginia Stormwater Management Program Handbook* (1999).

If the runoff, via the roof drain, is directed across the surface of the landscaping, then the amount of runoff that will be treated is dependent on the amount of vegetation the water will flow through before entering the storm drain system. In order to receive credits for DRDs on a commercial site, the runoff must be conveyed across a minimum length of landscaping or conveyance furrow. This minimum value is different for different rooftop sizes. The minimum values are calculated using a filter strip calculation which is a variation of Manning's equation to solve for hydraulic residence time. The Manning's equation used is the equation described in *Filter Strip Worksheet 2005 Surface Water Design Manual Sizing Method* published in the King County Surface Water Design Manual published by King County Water and Land Resources Division.

$$L = t \frac{Q}{W} \left( \frac{1.49W\sqrt{s}}{Qn} \right)^{0.6}$$

Where

L = filter strip length (feet)

t = hydraulic residence time (seconds)

Q = design flow (cfs)

W = filter strip width (feet)

n = Manning's roughness coefficient

s = longitudinal slope along path

$$WQF = C i A$$

Where

WQF = design flow (cfs)

C = Rational Runoff coefficient

i = rainfall intensity (in/hr)

A = Area (acres)

The equation is solved for hydraulic residence time, using various setback lengths and the following assumptions:

## Commercial Disconnected Roof Drain Assumptions

W = 8 feet (recommended by local hydrologist as typical average)

s = 0.01

n = 0.3 (commercial planter strip, will contain some bushes and larger plants)

Rooftop C = 0.9 (rational C) (corresponds to 100% imperviousness)

T = 7 minutes (standard residence time for treatment)

This results in the following setback/travel distance values for commercial sites.

Table 4 Minimum Travel Distance for Disconnected Roof Drains in Commercial/Multi-family Development Projects

Area (maximum roof size)	Length (min travel distance)	Depth of flow
3,500 sq ft	21 feet	0.4 in
5,000 sq ft	24 feet	0.5 in
7,500 sq ft	28 feet	0.6 in
10,000 sq ft	32 feet	0.7 in

### *Interceptor Trees*

Interceptor trees can prevent and/or delay water from landing on an impervious surface. Much of the intercepted water runs down along the tree's leaves and branches and evaporates, or runs down into the root system. Properly located trees can reduce the effective impervious fraction by diverting rain that would otherwise fall on streets and sidewalks. The *City of Portland Stormwater Management Manual* (2004) and City of San Jose policy apply 100 sq. ft of credit for a deciduous tree and 200 sq. feet for an evergreen tree. Research results published by Q. Xiao (1998, 2000(2), 2003) provides evidence that this credit system is appropriate. The number of trees is multiplied by the credit to obtain an area reduced by interceptor trees. Credits may be applied for existing trees as defined in Interceptor Trees Fact Sheet. To calculate the credits allowed for existing interceptor trees, the designer must identify the square footage equal to one half of the tree canopy. The resulting area is considered the area effectively managed by the existing interceptor trees.

### Using the Effective Area Managed in Calculating Treatment Requirement

After each Runoff Reduction measure has been addressed on the subforms, forms D-2a and D-2b, the  $A_c$  is totaled. This managed area is subtracted from the Area Requiring Treatment ( $A_T$ ) found in Step 1. The Adjusted Area Requiring Treatment ( $A_{AT}$ ) is also used to find an Adjusted Impervious Fraction ( $I_A$ ).

After the  $A_T$ ,  $A_{AT}$ , and  $I_A$  have been calculated, the water quality flow and/or volume must be calculated for sizing treatment controls. Whether the designer needs to calculate flow-based treatment or volume-based treatment depends on the type of treatment planned.

Treatment flow (WQF) is found using the standard flow equation,

$$WQF = C i A$$

where  $C$  is the rational runoff coefficient for  $A_{AT}$  (assumed to be 0.95),  $i$  is the rainfall intensity, and  $A$  is the adjusted area requiring treatment ( $A_{AT}$ ). This value is to be used when determining sizing criteria for structural treatment controls.

Treatment Volume (WQV) is found using either the CASQA method (Roseville):

$$V = A \times SV / 12$$

where  $A$  = the total area of the drainage shed,  $SV$  = the Unit Basin Storage Volume; use  $CA$  adjusted for credits earned (see Adjusted Runoff Coefficient, below).

Or the ASCE-WEF method (Sacramento):

$$WQV \text{ (ac-ft)} = P_o * A / 12$$

where  $A$  = the total area of the drainage shed,  $P_o$  = maximized detention volume using the ASCE-WEF method.

Please refer to Chapter 5 and Appendix E for the selection of the treatment measures and design requirements. Then use form D-1f, Treatment – Volume Based (CASQA) for volume-based treatment controls within the City of Roseville, or form D-1g, Treatment – Volume Based, for treatment controls in areas outside of the City of Roseville.

#### Adjusted Runoff Coefficient

The *Adjusted Impervious Fraction* is converted to an *Adjusted Runoff Coefficient*,  $C_A$ , using the empirical regression equation presented in the *California Stormwater BMP Handbook* (CASQA, 2003).

$$C = 0.858 I^3 - 0.78 I^2 + 0.774 I + 0.04$$

Where  $C$  = runoff coefficient,  $I$  = impervious fraction

The results of this equation for values of “ $I$ ” between 0 and 1 are listed in Table D-2d of Appendix D-2.

## IV. References.

Adams, M.C. 2003. *Porous Asphalt pavement with recharge beds: 20 years & still working*. Stormwater. May/June 2003.

*California Stormwater Best Management Handbook: New Development and Redevelopment*. California Stormwater Quality Association, 2003.

Cappiella, K. 2004. *Urban Watershed Forestry Manual (draft)*. Prepared for USDA Northeastern Area State and Private Forestry. Center for Watershed Protection, Ellicott City, MD.

Christensen, Summer. November 30, 2005. *Memorandum on Results of Residential Impervious Study*. County of Sacramento Department of Water Resources, Sacramento, CA.

*City of Davis Community Forest Management Plan*, September 11, 2002.  
<http://www.cityofdavis.org/pcs/trees/cfmp.cfm>

City of Pasadena. California Code of Regulations. Hollywood Driveway.  
<http://www.ci.pasadena.ca.us/zoning/P-8.html> accessed March 6, 2006.

*City of Portland Stormwater Management Manual*. Revision 3, September 1, 2004.

*High Point Community Site Drainage Technical Standards*. Seattle, WA, June 2004.

King County Department of Natural Resources and Parks. January 2005. *Stormwater Pollution Prevention Manual: Best Management Practices for Business and Residential Properties*. King County Washington.

*National Menu of Best Management Practices for Storm Water Phase II*. United States Environmental Protection Agency. 2002. <http://cfpub.epa.gov/npdes/stormwater/menuofbmps/index.cfm>

*New York State Stormwater Management Design Manual*. Center for Watershed Protection, New York State Department of Environmental Conservation, Albany, NY, October 2001.

Nonpoint Education for Municipal Officials. University of Connecticut. accessed May 26, 2006.  
<http://nemo.uconn.edu>

Paris N. and M. Chusid. 2006. *Coloring Pervious Pavement... because protecting the environment should be beautiful*. [www.ConcreteDecor.net](http://www.ConcreteDecor.net) Dec/Jan 2006.

Post-Construction Urban Runoff Management. City Council Policy. City of San Jose, California. February 3, 1998.

Shueler T., Swann C., Wright T, and S. Sprinkle. 2004. *Urban Subwatershed Restoration Manual No 8: Pollution Source Control Practices*. Version 1.0. Center for Watershed Protection. Ellicott City, MD. July 2004.

SMRC, The Stormwater Manager's Resource Center. Fact Sheets.  
[http://www.stormwatercenter.net/Assorted%20Fact%20Sheets/Tool6\\_Stormwater\\_Practices/Infiltration%20Practice/Porous%20Pavement.htm](http://www.stormwatercenter.net/Assorted%20Fact%20Sheets/Tool6_Stormwater_Practices/Infiltration%20Practice/Porous%20Pavement.htm) accessed June 14, 2006.

SMRC, The Stormwater Manager's Resource Center. Manual Builder.  
[http://www.stormwatercenter.net/Manual\\_Builder/Credits/SITE/reforestation.htm](http://www.stormwatercenter.net/Manual_Builder/Credits/SITE/reforestation.htm)

SMRC, The Stormwater Manager's Resource Center. Manual Builder.  
[http://www.stormwatercenter.net/Manual\\_Builder/Credits/SITE/rooftop.htm](http://www.stormwatercenter.net/Manual_Builder/Credits/SITE/rooftop.htm)

*Start at the Source - Design Guidance Manual for Stormwater Quality Protection*, Bay Area Stormwater Management Agencies Association, 1999.

*Stormwater C.3 Guidebook: Stormwater Quality Requirements for Development Applications*. Contra Costa Clean Water Program. Contra Costa, CA, March 2005.

*Stormwater Pollution Prevention Manual: Best Management Practices for Business and Residential Properties*. King County Department of Natural Resources and Parks, Water and Land Resources Division, Stormwater Services Section. January 2005.

*Sustainable Infrastructure Alternative Paving Materials Subcommittee Report*. City of Portland. October 3, 2003.

*The Practice of Low Impact Development*. U.S. Department of Housing and Urban Development. Washington, D.C. July 2003.

*Truckee Meadows Regional Storm Water Quality Management Program: Draft Low Impact Development Handbook*. August 2005.

*Urban Storm Drainage Criteria Manual Volume 3 – Best Management Practices*. Urban Drainage and Flood Control District. Denver, CO. September, 1999 (Rev. October, 2005).

*Virginia Stormwater Management Program Handbook*. Virginia Department of Conservation and Recreation. 1999.

Xiao Q., and E.G. McPherson. 2003. *Rainfall interception by Santa Monica's municipal urban forest*. Urban Ecosystems

Xiao, Q., E.G. McPherson, S.L. Ustin and M.E. Grismer. 2000. *A new approach to modeling tree rainfall interception*. Journal of Geophysical Research 105(D23) :29,173-29,188.

Xiao, Q. 1998. *Rainfall interception by urban forests*. Davis, CA: University of California. Ph.D. Dissertation.

Xiao, Q., E.G. McPherson, S.L. Ustin, M.E. Grismer, and J.R. Simpson. 2000. *Winter rainfall interception by two mature open grown trees in Davis, CA*. Hydrological Processes. 14(4):763-784.



# Appendix E. Design Requirements for Stormwater Quality Treatment Control Measures

---

THIS PAGE INTENTIONALLY LEFT BLANK

# Appendix E Design Requirements for Stormwater Quality Treatment Control Measures (Volume and Flow-Based Measures)

---

The Sacramento Areawide NPDES Municipal Stormwater Permit contains provisions that require the local municipal agencies to establish and enforce stormwater quality treatment standards for many new and redevelopment projects. This appendix presents the minimum standards for sizing the treatment control measures.

## General Methodology

Follow these steps:

- Refer to Table 3-2 in this Design Manual to determine if your project requires treatment control measures.
- Once you have made that determination, use the fact sheets in Chapter 6 to identify the type of control measures most appropriate for your project site and whether or not those measures are volume or flow-based.
- (Optional) Use Chapter 5 and the runoff reduction worksheets in Appendix D to select runoff reduction measures for your project which will reduce the runoff discharged; this may result in reduced treatment needs (and associated costs) for your project.
- Use the rest of the information in this appendix to size the treatment control facilities for your project.

The local Sacramento agencies have developed a presumptive approach, whereby, if project applicants follow the methodology presented herein, it is presumed that the project is reducing stormwater pollution in runoff to the “maximum extent practicable” NPDES municipal permit standard. A key principle here is that treatment control measures are most efficient and economical when they target small, frequent storm events that over time produce more total runoff than the larger, infrequent storms conventionally targeted for design of flood control facilities. Further, studies in other areas of the country have shown that much of the pollutant load is contained in the “first flush” of rainfall during a storm event, typically the first 0.5-inches. Targeting design storms larger than this may result in some improvements in pollutant removal effectiveness, but at considerable cost.

It is important to note that arbitrarily targeting large, infrequent storm events can actually reduce the pollutant removal capabilities of some treatment control measures. This occurs when outlet structures, detention times, and drain down times are designed to accommodate unusually large volumes and high flows. When over-designed in this way, the more frequent, small storms that

produce the most annual runoff and a large part of the pollutant load pass quickly through the oversized facility and therefore receive inadequate treatment. (CASQA, 2003).

## Sizing Flow-Based Treatment Control Measures

Use this method for sizing flow-based control measures (e.g., vegetated swales).

Flow-based control measure design standards apply to control measures whose primary mode of pollutant removal depends on the rate of flow of runoff through the facility or device. Examples of control measures in this category include swales, sand filters, diversion structures for off-line control measures, and many proprietary products. Typically, flow-based design criteria calls for the capture and infiltration or treatment of the flow runoff produced by rain events of a specified magnitude. For the local area, the intensity of such a storm event is 0.20 inches/hour for the City of Folsom and 0.18 inches/hour for other cities in Sacramento County and unincorporated Sacramento County.

This method satisfies the provisions of the Sacramento Areawide NPDES Municipal Stormwater Permit, which requires that flow-based measures be designed for at least the maximum (peak) flow rate of runoff produced by the 85th percentile hourly precipitation intensity multiplied by a factor of two, referred to here as the flow-based 85th percentile method. (CDM, 2003). This criterion is the same as the one prescribed by the 2003 California BMP Handbook. From Appendix D of that handbook, the 85th percentile hourly precipitation intensity for the Sacramento gage is approximately 0.09 inches/hour. Multiplying by two, the required intensity is at least 0.18 inches/hour. The factor of two specified for this method by the municipal stormwater permits appears to be provided as a factor of safety: therefore, caution should be exercised when applying additional factors of safety during the design process so that over design can be avoided. (CASQA, 2003).

The flow-based BMP design criteria should be used in conjunction with the Rational Formula, a simplified, easy to apply formula that predicts flow rates based on rainfall intensity and drainage area characteristics. The Rational Formula is as follows:

$$WQF \text{ (cfs)} = C i A$$

where

WQF = flow in ft<sup>3</sup>/s

i = rain intensity in inches/hr

A = drainage area in acres

C = rational runoff coefficient

The Rational Formula is widely used for hydrologic calculations, but it does have a number of limitations. For stormwater treatment control measure design, a key limitation is the ability of the Rational Formula to predict runoff from undeveloped areas where runoff coefficients are highly

variable with storm intensity and antecedent moisture conditions. This limitation is accentuated when predicting runoff from frequent, small storms used in stormwater quality treatment design because many of the runoff coefficients in common use were developed for predicting runoff for drainage design where larger, infrequent storms are of interest. Table 5-3 in the California BMP Handbook (May 2003) provides some general guidelines on use of the Rational Equation. In summary, the Rational Formula, when used with commonly tabulated runoff coefficients in undeveloped drainage areas, will likely result in predictions higher than will be experienced under actual field conditions. However, given the simplicity of the equation, its use remains practical and it is therefore the preferred method recommended by the local permitting agencies.

The following steps describe the approach for application of the flow-based design criteria. For simplicity, the worksheets presented in Appendix D (see Step 3 of Appendix D-1 and D-2) already incorporate these steps.

1. Identify and delineate the drainage shed that drains to the proposed control measure. This includes all areas that will contribute runoff to the proposed control measure, including pervious areas, impervious areas, and off-site areas, whether or not they are directly or indirectly connected to the control measure.
2. Select design rainfall intensity for the project area:  
0.20 inches/hour – projects in the City of Folsom  
0.18 inches/hour – projects located in other cities in Sacramento County and unincorporated Sacramento County
3. Calculate the composite runoff coefficient “C” for the drainage shed identified in Step 1 using table E-1. For contributing areas with multiple coefficients, use the weighted coefficient for the contributing area.
4. Apply the Rational Formula to calculate the water quality design flow (WQF).

$$WQF = C i A$$

Table E-1: Runoff coefficients for the Rational Formula

Type of Drainage Area	Runoff Coefficient, C
<b>Business</b>	
Downtown areas	0.95
Neighborhood areas	0.70
<b>Residential</b>	
Single-family areas	0.50
Multi-units, detached	0.60
Multi-units, attached	0.75
Apartment dwelling areas	0.70
<b>Industrial</b>	
Light areas	0.80
Heavy areas	0.90
Parks, cemeteries	0.25
Playgrounds	0.40
Railroad yard areas	0.40
Unimproved area	0.30
<b>Lawns</b>	
Sandy soil, flat, 2%	0.10
Sandy soil, average, 2-7%	0.15
Sandy soil, steep, 7%	0.20
Heavy soil, flat, 2%	0.17
Heavy soil, average, 2-7%	0.22
Heavy soil, steep, 7%	0.35
<b>Streets</b>	
Asphaltic	0.95
Concrete	0.95
Brick	0.85
Drives and Walks	0.85
Roofs	0.95

## Sizing Volume-Based Treatment Control Measures

Volume-based design standards apply to control measures whose primary mode of pollutant removal depends on the volumetric capacity of the facility. Examples of control measures in this category include water quality detention basins, constructed wetlands, stormwater planters, and infiltration basins/trenches. Volume-based design criteria calls for the capture and infiltration or treatment of a certain percentage of the runoff from the project site, usually in the range of the 75th to 85th percentile average annual runoff volume.

The agencies in Sacramento County require use of the Urban Runoff Quality Management method for sizing volume-based control measures. This method is one of the three alternative design approaches allowed by the NPDES municipal stormwater permits.

## Sacramento County Volume-Based Design Method

For projects in Sacramento County, volume-based control measures shall be designed to capture and treat the maximized stormwater quality capture volume for the area, based on historical rainfall records, determined using the formula and volume capture coefficients set forth in Urban Runoff Quality Management (WEF Manual of Practice No. 23/ASCE Manual of Practice No. 87, (1998), pages 175-178). The Urban Runoff Quality Management approach (also known as WEF/ASCE approach) is based on the translation of rainfall to runoff using two regression equations. The first regression equation relates rainfall to runoff. The rainfall to runoff regression equation was developed using 2 years of data from more than 60 urban watersheds nationwide. The second regression equation relates mean annual runoff-producing rainfall depths to the “Maximized Water Quality Capture Volume” which corresponds to the “knee of the cumulative probability curve”. This second regression was based on analysis of long-term rainfall data from seven rain gages representing climatic zones across the country. The Maximized Water Quality Capture Volume corresponds to approximately the 85th percentile runoff event, and ranges from 82 to 88%.

The two regression equations that form the Urban Runoff Quality Management approach are as follows:

$$C = 0.858 I^3 - 0.78 I^2 + 0.774 I + 0.04$$

$$P_o = (a \cdot C) \cdot P_6$$

Where

C = runoff coefficient;

I = watershed imperviousness ratio which is equal to the percent total imperviousness divided by 100;

P<sub>o</sub> = Maximized Detention Volume, in watershed inches;

a = regression constant, a= 1.312 for 12 hrs, a=1.582 for 24 hrs, and a=1.963 for 48-hour draw down time.

P<sub>6</sub> = mean annual runoff-producing rainfall depths, in watershed inches.

The following steps describe the use of the approach. For simplicity, the worksheets presented in Appendix D (see Step 3 of Appendix D-1 and D-2) already incorporate these steps.

1. Identify the drainage shed (A in acres) that drains to the proposed control measure. This includes all areas that will contribute runoff to the proposed facility, including pervious areas, impervious areas (such as roofs, roads, parking lots, etc), and off-site areas, whether or not they are directly or indirectly connected to the control measure.
2. Determine the “Maximized Detention Volume” (P<sub>o</sub>) in inches for the drainage shed. Please refer to the attached figures (figure E-1 through figure E-4).
3. Calculate the required water quality volume of the control measure by multiplying the drainage shed area from Step 1 by the “Maximized Detention Volume” from Step 2.

$$WQV \text{ (ac-ft)} = P_o \cdot A / 12$$

## References

California Stormwater Quality Association (CASQA), 2003. *California Stormwater BMP Handbook for New Development and Redevelopment*, [www.cabmphandbooks.com](http://www.cabmphandbooks.com).

Development Standards Plan, Dec. 2003. *Appendix F: Technical Memorandum- Review of Design Criteria for Stormwater Quality Treatment Facilities for the Sacramento Stormwater Management Program*.

Placer Regional Stormwater Coordination Group (PRSCG). May 2005. *Guidance Document for Volume and Flow-Based Sizing of Permanent Post-Construction Best Management Practices for Stormwater Quality Protection*.

US Department of Transportation, Federal Highway Administration. November 1996. *Urban Drainage Design Manual, Hydraulic Engineering Circular No. 22, FHWA-SA-96-078*.

Water Environment Federation and American Society of Civil Engineers (WEF and ASCE). 1998. *Urban Runoff Quality Management*. WEF Manual of Practice No. 23 and ASCE Manual and Report on Engineering Practice No. 87.



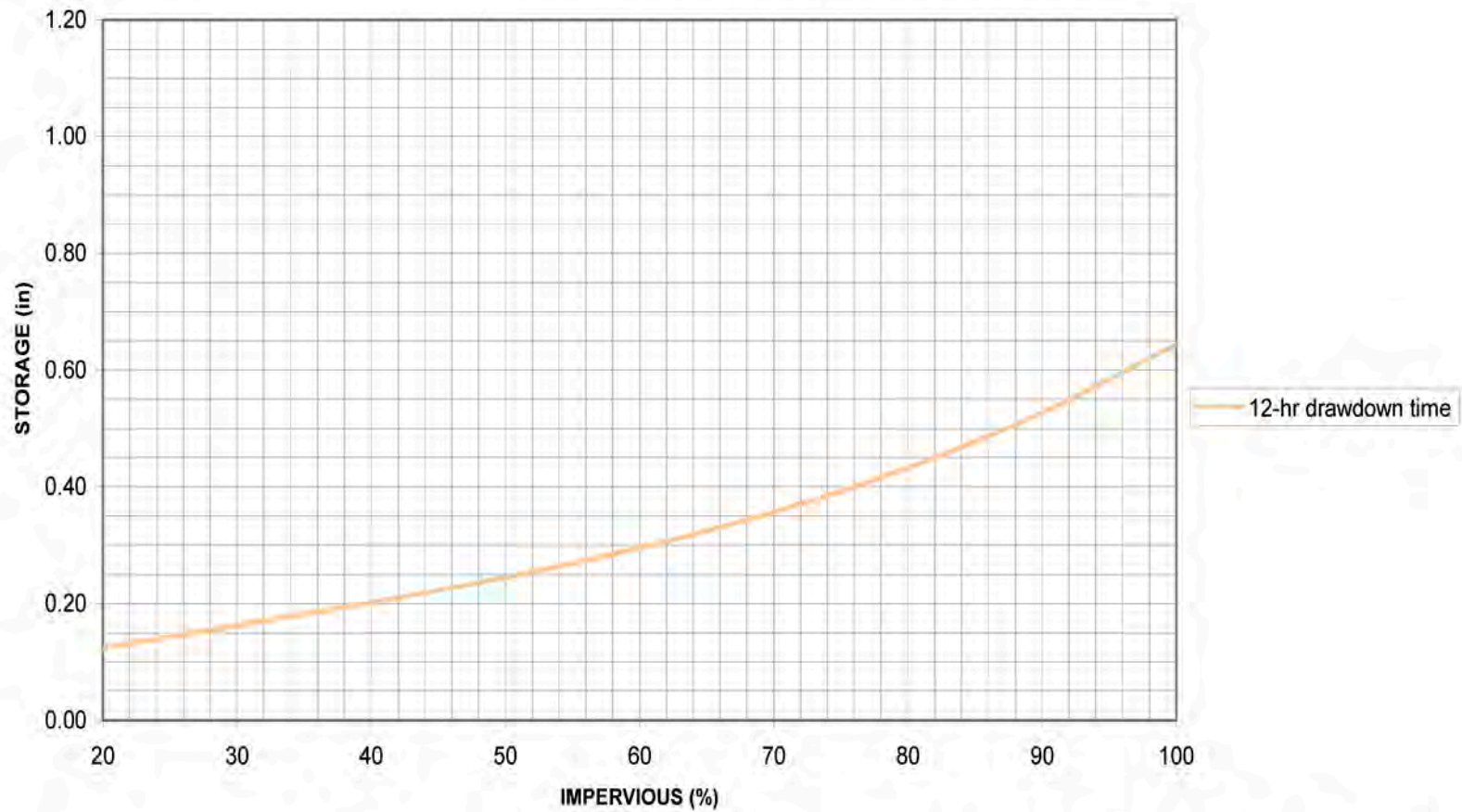

Source: URBAN RUNOFF QUALITY MANAGEMENT: WEF Manual of Practice No. 23 and Report on Engineering Practice No. 87.

**Curve for Maximized  
Detention Volume  $P_0$**

Date: August  
2006

Figure: E-1

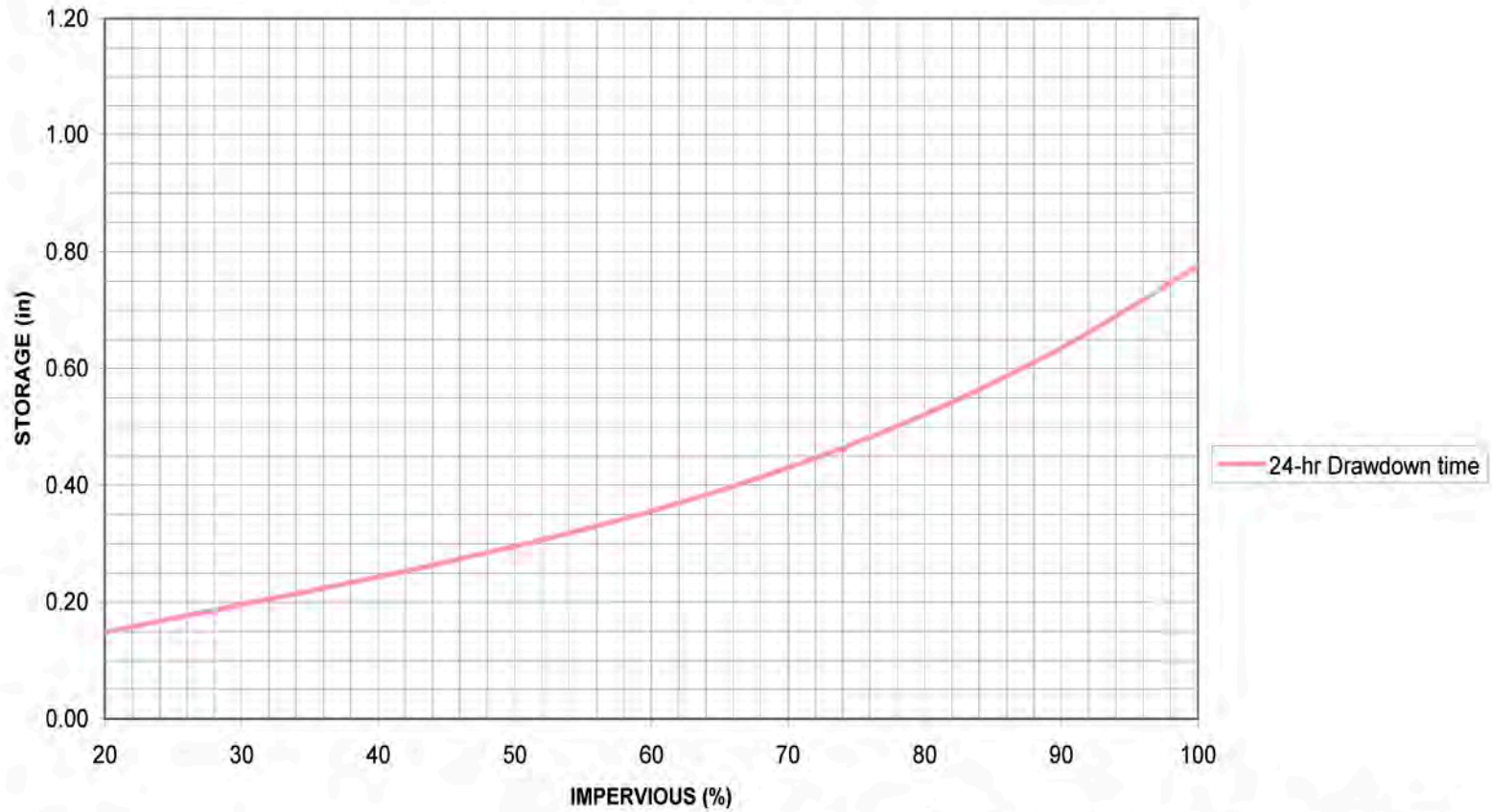

Source: URBAN RUNOFF QUALITY MANAGEMENT: WEF Manual of Practice No. 23 and Report on Engineering Practice No. 87.

**Curve for Maximized  
Detention Volume  $P_0$**

Date: August  
2006

Figure: E-2

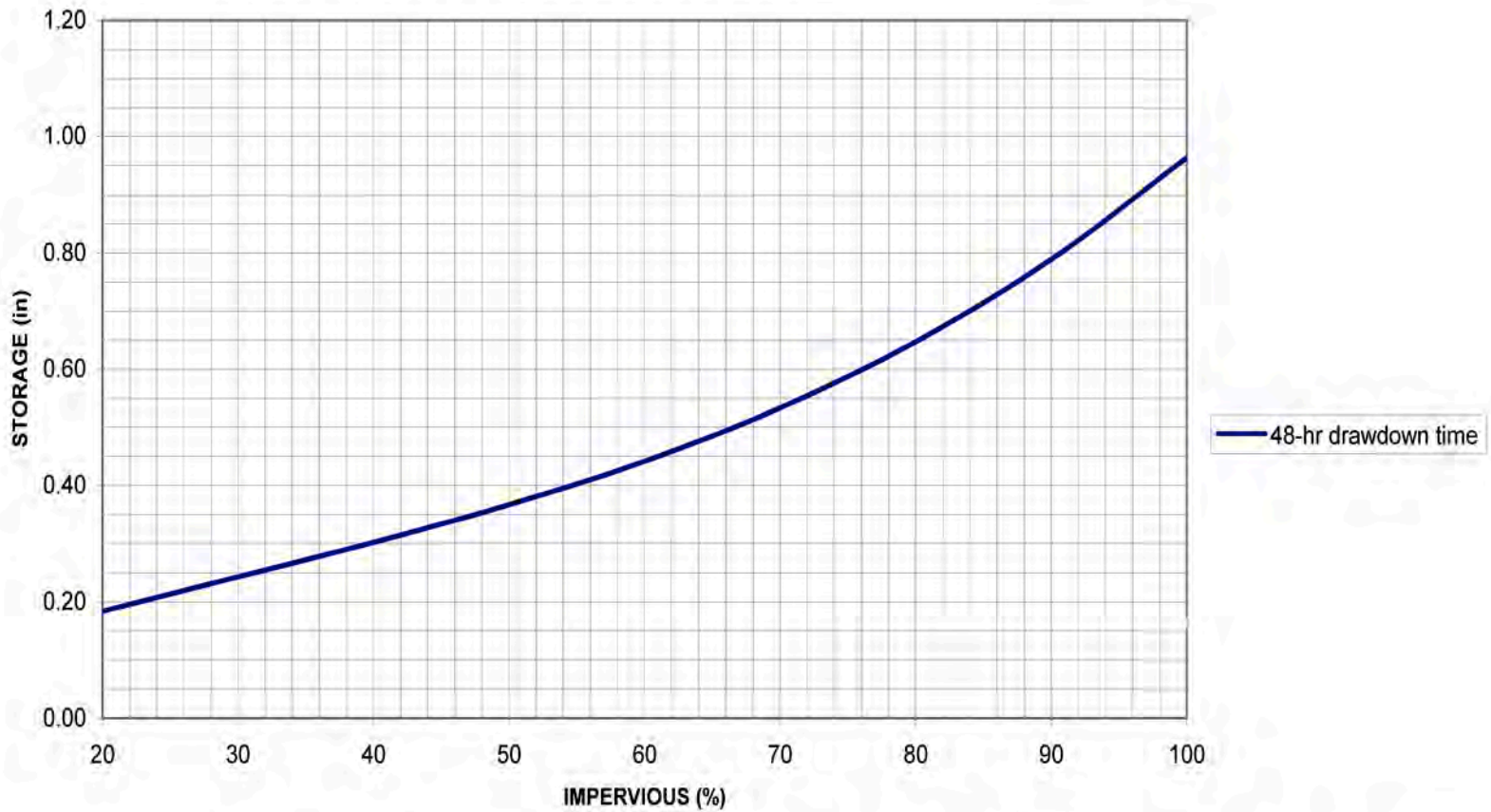

Source: URBAN RUNOFF QUALITY MANAGEMENT: WEF Manual of Practice No. 23 and Report on Engineering Practice No. 87.

**Curve for Maximized Detention Volume  $P_0$**

Date: August 2006

Figure: E-3

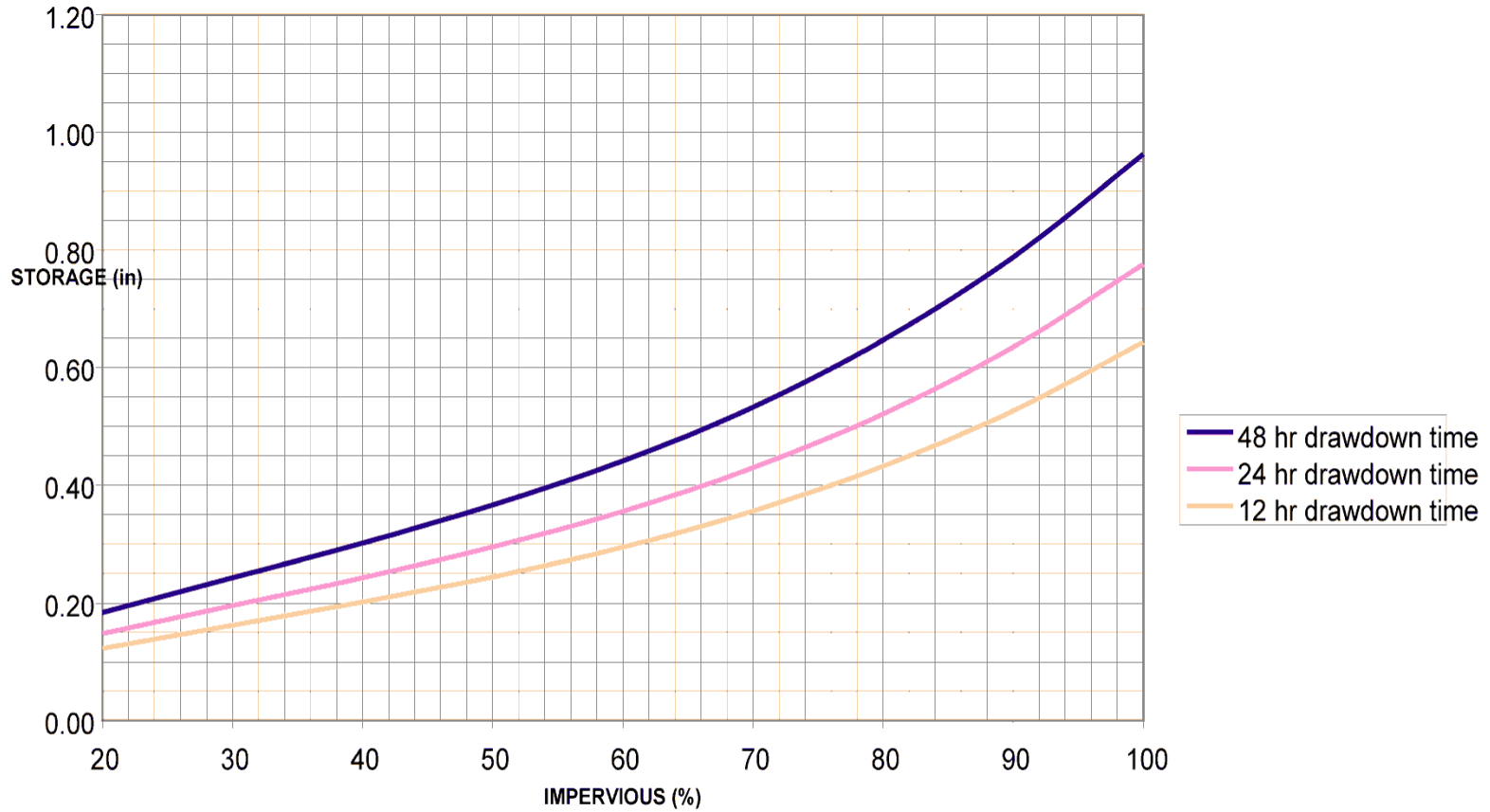

Source: URBAN RUNOFF QUALITY MANAGEMENT: WEF Manual of Practice No. 23 and Report on Engineering Practice No. 87.

<b>Curve for Maximized Detention Volume <math>P_0</math></b>	Date: August 2006
	Figure: E-4

# Appendix F. Drainage Design and Stormwater Management Information Not Included in the Design Manual

---

THIS PAGE INTENTIONALLY LEFT BLANK

# Appendix F Drainage Design and Stormwater Management Information Not Included in the Design Manual

---

## Drainage/Flood Control Design Reference Documents

The design manual does not contain general drainage design standards and details. For that information refer to:

City and County of Sacramento Drainage Manual -Volume II Hydrology Standards can be downloaded at <http://www.waterresources.saccounty.net/Pages/ReportsPublications.aspx> or hard copy/CD can be purchased from Sacramento County. Contact the Sacramento County Dept. of Water Resources at (916) 874-6851 for ordering information.

City of Sacramento Department of Utilities Procedures Manual and Utility Standards – Electronic copies can be downloaded at <http://www.cityofsacramento.org/Public-Works/Engineering-Services/Permits/Plan-Check> . Hard copies can be purchased at the City Department of Utilities or one of the two City Permit Centers; call (916) 808-1400 for more information.

City of Folsom Design and Procedures Manual – Electronic copy can be downloaded at: [https://www.folsom.ca.us/city\\_hall/depts/community/engineering/engineering\\_forms\\_n\\_information/default.asp](https://www.folsom.ca.us/city_hall/depts/community/engineering/engineering_forms_n_information/default.asp) . Or contact the City Department of Public Works for more information at (916) 355-7272.

## Construction Erosion and Sediment Control Documents

Sacramento County Improvement Standards (Section 11: Erosion and Sediment Control). (These standard details area also used by cities in Sacramento; check with your local permitting agency for verification.) Electronic copies can be downloaded at <http://www.engineering.saccounty.net/Pages/ImprovementStandards.aspx>. Hard copies can be purchased at: 827 7th Street, Sacramento, CA 95814, at the cashier’s office on first floor.

## Industrial/Commercial Facility Operational BMP Guidance Documents

Sacramento County and Cities in Sacramento County: Guidance materials are published by the Sacramento County Environmental Management Department, which is responsible for conducting stormwater compliance inspections of many industrial/commercial facilities in the county. Visit <http://www.emd.saccounty.net/EH/Pages/Stormwater.aspx> for more information.

Statewide Guidance: California Stormwater Best Management Practice Handbook (Industrial and Commercial Edition), CASQA, 2003. <https://www.casqa.org/resources/bmp-handbooks>

This Page Left Intentionally Blank



# Appendix G. Inspection Checklist for Stormwater Control Measures

---

THIS PAGE INTENTIONALLY LEFT BLANK

# Inspection Checklist for Stormwater Control Measures

The City/ County inspector is required to verify these listed items for Post Construction Stormwater Quality Measures before signing off on the project:

## *All Projects:*

- BMPs are correctly and permanently installed (including any necessary vegetation), per the approved plans and/or maintenance agreement for the property.
- Landscaped areas are stabilized
- Inlets and curb-cuts are installed to provide smooth entry of runoff from adjoining pavement. **Curb-cuts shall be 12-inch minimum**
- Inflows from roof leaders and pipes are **NOT** directly connected to the underground drainage system
- Rock or other energy dissipation at piped discharge and curb-cuts is adequate
- Overflow outlets are configured to allow the facility to fill to near rim before overflow
- Plantings are healthy and becoming established
- Weeds and invasive plants have been removed
- Irrigation system is operable; there are no leaks or breaks in the system and the system does not overspray outside of the facility
- Site is graded and drains as designed; no surface ponding is evident
- Any accumulated construction debris, trash, or sediment is removed from all stormwater measures
- All gravel bags and inlet protection is removed
- Vegetated BMPs are free of erosion or scouring
- BMP is free of standing water and unpleasant odors
- Filter media pouches, booms, cartridges, etc. associated with a permanent BMP are completely secured, intact, and in working condition.

## *Vegetated Swale*

- Energy dissipater or flow spreader at swale inlet is free and clear of sediment and is not blocked by overgrown vegetation
- Positive longitudinal slope to the swale outlet
- No bark mulch shall be placed in the vegetated swale
- The swale is vegetated as detailed in the approved improvement plans
- Underdrain is installed per approved improvement plans (if applicable)
- Filter fabric or filter layer is installed per approved improvement plans **(not wrapped around underdrain!!)**

## *Stormwater Planter*

- Minimum of 6-inch storage depth
- Verify material for Top layer, 18-inch Sand/Peat layer and Gravel layer
- Overflow inlet grade is not below the minimum storage line.
- Underdrain for flow-through planter is installed per approved improvement plans
- Filter fabric or filter layer is installed per approved improvement plans **(not wrapped around underdrain!!)**

## *Proprietary Devices*

- Completion of installation per Manufacturer's specification
- Certification letter from manufacturer to verify the proper installation of the device.

THIS PAGE LEFT INTENTIONALLY BLANK

# Appendix H. Amendment to the Water Quality Control Plan for Ocean Waters of California to Control Trash (Ocean Plan) and Certified Full Capture Systems List of Trash Treatment Control Devices

---

THIS PAGE INTENTIONALLY LEFT BLANK

## Certified Trash Full Capture Systems List Of Multi-Benefit Treatment Systems

The State Water Resources Control Board (State Water Board) promotes Low Impact Development (LID) designs to capture, reuse, treat, and/or infiltrate storm water runoff. The LID systems and individual treatment controls (Multi-Benefit Treatment Systems) listed below meet the Full Capture System definition and are certified for use by the State Water Board Executive Director, or designee, provided the Multi-Benefit Treatment System performs as follows:

1. Prohibits the discharge of particles 5 mm or greater to surface waters off site;
2. Contains a capacity greater than the volume collected during the region specific one-year, one-hour storm event from the applicable drainage area; or a capacity to carry at least the same flows as the corresponding storm drain;
3. Incorporates an operation and maintenance plan sufficient to ensure that the captured trash does not migrate from the site; and
4. Has stamped and signed design plans by a registered California licensed professional civil engineer (see Bus. & Prof. Code Section 6700, et seq.).

The Executive Director reserves the right to remove any Multi-Benefit System from this list.

<a href="#" style="color: white; text-decoration: none;"><u>System Description</u></a> (click links to access information sheets)
<a href="#" style="color: blue; text-decoration: none;"><u>Bioretention</u></a>
<a href="#" style="color: blue; text-decoration: none;"><u>Capture and Use Systems</u></a>
<a href="#" style="color: blue; text-decoration: none;"><u>Detention Basin</u></a>
<a href="#" style="color: blue; text-decoration: none;"><u>Infiltration Trench or Basin</u></a>
<a href="#" style="color: blue; text-decoration: none;"><u>Media Filter</u></a>

# Bioretention

## Trash Best Management Practices (BMP)

### Minimum Specifications



Figure A: CA State University-Sacramento Bioretention BMP

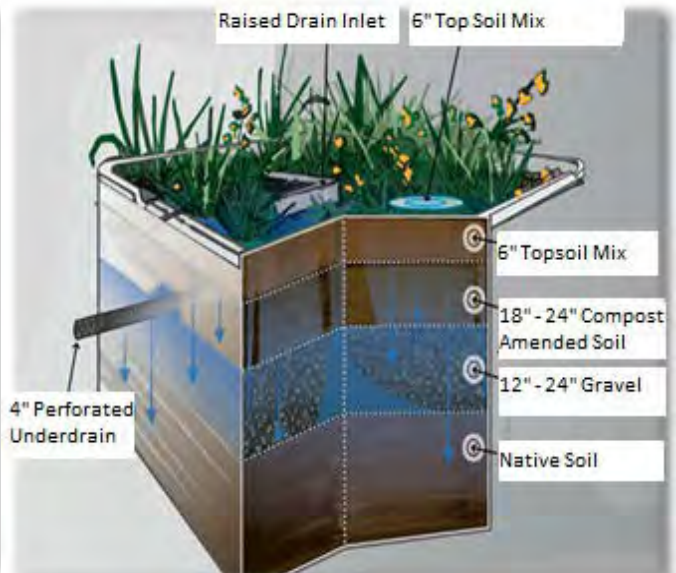

Figure B. American Common Bio-Swale Detail

#### Description

Bioretention BMPs, including bio-swales, remove pollutants from storm water runoff through physical filtration as storm water passes through media layers. The treatment area consists of: a ponding layer; vegetated, mulched, and engineered soil layer; and supporting bed layer of sand or gravel. Bioretention BMPs can be a variety of shapes and sizes. Storm water entering the treatment area evapotranspires or gradually passes through the mulch/soil/gravel layers where it then infiltrates into native soil or collects in an underdrain that conveys to a discharge point.

#### Performance and Design

The bioretention BMP must be designed to trap trash particles that are 5 mm or greater and prevent offsite migration, and the design must include:

1. A screen<sup>1</sup> that prohibits the discharge of particles 5 mm or greater at the BMP overflow or bypass outlet;
2. A treatment capacity equal to or greater than the volume collected during the region specific one-year, one-hour storm event from the applicable drainage area; or a capacity to carry at least the same flows of the corresponding storm drain; and
3. Stamped and signed design plans by a registered California licensed professional civil engineer (see Bus. & Prof. Code Section 6700, et seq.).

#### Maintenance

Regular maintenance is required to maintain adequate trash capture capacity and to ensure that trapped trash does not migrate offsite. The owner should establish a maintenance schedule based on site-specific factors, including the size of the bioretention BMP trench, storm frequency, and characterization of upstream trash and vegetation accumulation. Trash capture and maintenance may be improved by addition of various forms of pretreatment, such as upstream swales or forebays.

<sup>1</sup> Upon approval by the Regional Water Quality Control Board Executive Officer, an external design feature or up-gradient structure designed to bypass flows exceeding the region specific one-year, one-hour, storm event does not require a 5 mm screen.



# Storm Water Capture and Use

## Trash Best Management Practices (BMP) Minimum Specifications

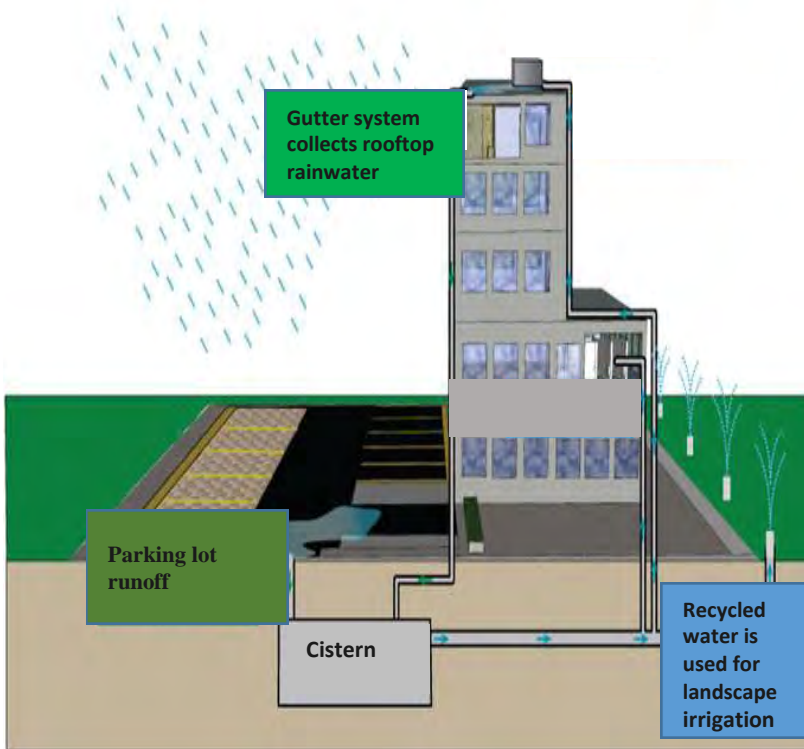

Figure A: Cistern used to capture storm water for onsite use  
*San Diego County LID Handbook Photo*



Figure B: Large Scale Capture and Use Tank

### Description

Storm Water Capture and Use BMPs capture and store runoff for use in a variety of applications including irrigation, toilet flushing, and other non-potable uses. There are numerous methods of capturing storm water for use including some of the other certified Multi-Benefit Treatment Systems.

### Performance and Design

The Storm Water Capture and Use BMP design must include:

1. A screen<sup>1</sup> that prohibits the discharge of particles 5 mm or greater at the BMP overflow or bypass outlet;
2. A treatment capacity equal to or greater than the volume collected during the region specific one-year, one-hour storm event from the applicable drainage area; or a capacity to carry at least the same flows of the corresponding storm drain; and
3. Stamped and signed design plans by a registered California licensed professional civil engineer (see Bus. & Prof. Code Section 6700, et seq.).

### Maintenance

Regular maintenance is required to maintain adequate trash capture capacity for the generated runoff of the anticipated storm. The owner should establish a maintenance schedule based on site-specific factors, including the size of the Storm Water Capture BMP, storm frequency, and characterization of upstream trash and vegetation accumulation.

<sup>1</sup> Upon approval by the Regional Water Quality Control Board Executive Officer, an external design feature or up-gradient structure designed to bypass flows exceeding the region specific one-year, one-hour, storm event does not require a 5 mm screen.

# Detention Basin

## Trash BMP Minimum Specifications



Figure A: Detention Basin BMP

### Description

A detention basin BMP, or retarding basin, is a local topographic depression designed to reduce potential for flooding by reducing peak flow rates. These basins are also called "dry ponds," "holding ponds," or "dry detention basins," and are distinguishable from *retention basins* that are commonly known as "wet ponds" and designed to contain some water all-year-round. Detention basins may also be located underground in an array of pipe, chambers, concrete vaults, or other void structures.

### Performance and Design

The detention basin BMP must be designed to trap trash that are 5 mm or greater and prevent offsite migration, and include:

1. A screen<sup>1</sup> that prohibits the discharge of particles 5 mm or greater at the BMP overflow or bypass outlet;
2. A capacity equal to or greater than the volume collected during the region specific one-year, one-hour storm event from the applicable drainage area; or the capacity to contain at least the same flows of the corresponding storm drain; and
3. Stamp and signed design plans by a registered California licensed professional civil engineer (see Bus. & Prof. Code Section 6700, et seq.).

### Maintenance

Regular maintenance is required to maintain adequate trash capture capacity and ensure that trapped trash does not migrate offsite. The owner should establish a maintenance schedule based on site-specific factors, including the size of the detention basin BMP, storm frequency, and characterization of upstream trash and vegetation accumulation. Trash capture and maintenance may be improved by the addition of various forms of pretreatment, such as upstream swales or forebays.

---

<sup>1</sup> Upon approval by the Regional Water Quality Control Board Executive Officer, an external design feature or up-gradient structure designed to bypass flows exceeding the region specific one-year, one-hour, storm event does not require a 5 mm screen.

# Infiltration Trench or Basin

## Trash Best Management Practices (BMP) Minimum Specifications



Figure A: Urban Infiltration Trench BMP

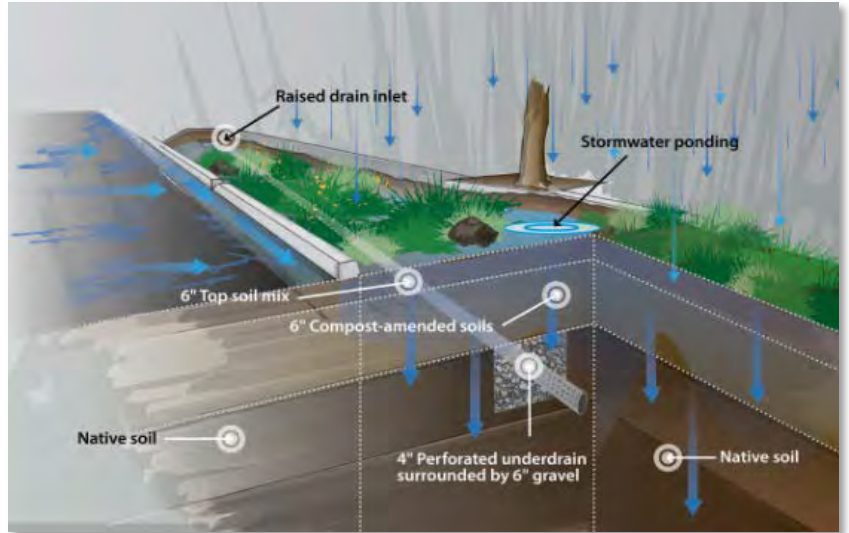

Figure B: CA State University-Sacramento Generic Urban Infiltration Trench BMP Detail

### Description

An infiltration trench or basin BMP captures and infiltrates storm water runoff into native soils. Infiltration trench or basin BMPs come in a variety of shapes and sizes and the final appearance may vary substantially. Infiltration trenches may be backfilled with porous media such as gravel, sand, Cornell Soil, or various locally earthed rocks known not to generate pollutants of concern to the downstream waters. Subsurface designs may be comprised of perforated pipe, chambers, open bottom concrete galleries or other high voids structures. These trenches and basins store the design water quality volume for infiltration to underlying soils.

### Performance and Design

The infiltration trench BMPs must be designed to trap trash particles that are 5 mm or greater and prevent offsite migration, and the design must include:

1. A screen<sup>1</sup> that prohibits the discharge of particles 5 mm or greater at the BMP overflow or bypass outlet;
2. A treatment capacity equal to or greater than the volume collected during the region specific one-year, one-hour storm event from the applicable drainage area, or a capacity to carry at least the same flows of the corresponding storm drain; and
3. Stamp and signed design plans by a registered California licensed professional civil engineer (see Bus. & Prof. Code Section 6700, et seq.).

### Maintenance

Regular maintenance is required to maintain adequate trash capture capacity and to ensure that captured trash does not migrate offsite. The owner should establish a maintenance schedule based on site-specific factors, including the size of the infiltration trench BMP, storm frequency, and characterization of upstream trash and vegetation accumulation. Trash capture and maintenance may be improved by addition of various forms of pretreatment, such as upstream swales, forebays, or manufactured treatment systems.

<sup>1</sup> Upon approval by the Regional Water Quality Control Board Executive Officer, an external design feature or up-gradient structure designed to bypass flows exceeding the region specific one-year, one-hour, storm event does not require a 5 mm screen.

# Media Filter

## Trash Best Management Practices (BMP)

### Minimum Specifications



**Figure A: Media Filter BMP Image**  
*County of San Diego LID Handbook BMP Image*

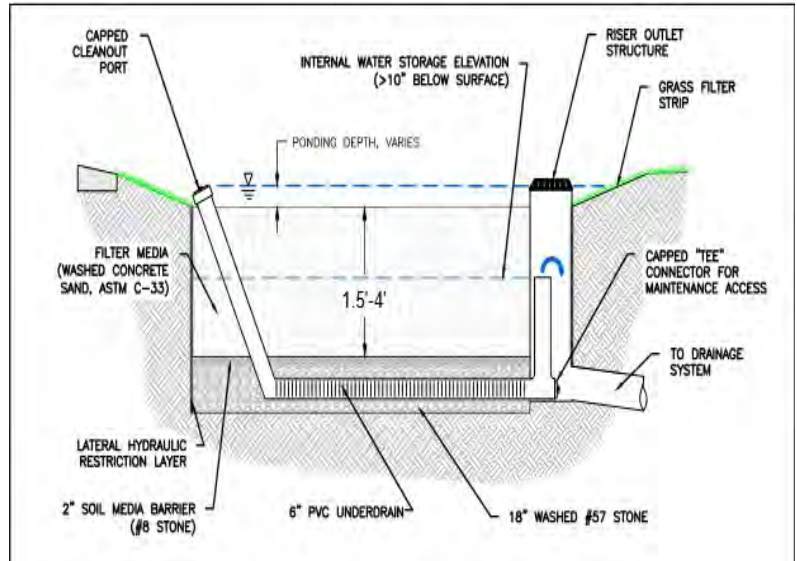

**Figure B: Generic Media Filter BMP Detail**  
*County of San Diego LID Handbook BMP Image*

### Description

A media filter BMP uses a bed of sand, peat, zeolite, anionic and/or cationic media, granite or other fine grained materials or fabrics to physically separate sediment and sediment-bound pollutants and/or electro-chemically remove dissolved constituents from storm water.

### Performance and Design

The media filter BMP must be designed to trap trash particles 5 mm or greater and prevent offsite migration, and the design must include:

1. A screen<sup>1</sup> that prohibits the discharge of particles 5 mm or greater at the BMP overflow or bypass outlet;
2. A treatment capacity equal to or greater than the volume collected during a one-year, one-hour storm event from the applicable drainage area; or a capacity to carry at least the same flows as the corresponding storm drain; and
3. Stamped and signed design plans by a registered California licensed professional civil engineer (see Bus. & Prof. Code Section 6700, et seq.).

### Maintenance

Regular maintenance is required to maintain adequate trash capture capacity and to ensure that captured trash does not migrate offsite. The owner should establish a maintenance schedule based on site-specific factors including the size of the media filter BMP, storm frequency, and characterization of upstream trash and vegetation accumulation. Trash capture and maintenance may be improved by addition of various forms of pretreatment, such as upstream swales or forebays.

<sup>1</sup> Upon approval by the Regional Water Quality Control Board Executive Officer, an external design feature or up-gradient structure designed to bypass flows exceeding the region specific one-year, one-hour, storm event does not require a 5 mm screen.

# Appendix I. Bioretention Soil Media Specifications

---

THIS PAGE INTENTIONALLY LEFT BLANK

# Appendix I Bioretention Soil Media Specifications

(Designs should follow these specifications unless otherwise specified by your local permitting agency.)

BSM Composition	Sand	Sandy Loam			Compost
		Sand	Silt	Clay	
Volume	65%	20%			15%
Weight	75-80%	10% max	3% max	9% max (9% compost by weight results in approximately 5% organic matter by weight)	
General Notes: Bioretention Soil Media (BSM) should provide a long-term, in-place infiltration rate of 5 inches per hour. BSM should also support plant growth while providing pollutant treatment.					

BSM Component	Description																													
<b>Sand</b>	<p><i>Quality:</i> Sand should be thoroughly washed before delivery and should be free of wood, waste, and coatings such as clay, carbonate, stone dust, or other deleterious material. All aggregate passing the No. 200 sieve size should be non-plastic.</p> <p><i>Texture:</i> Sand should meet the following gradation:</p> <table border="1"> <thead> <tr> <th rowspan="2">Sieve Size</th> <th colspan="2">Percent Passing (by weight)</th> </tr> <tr> <th>Min.</th> <th>Max.</th> </tr> </thead> <tbody> <tr> <td>3/8 inch</td> <td>100</td> <td>100</td> </tr> <tr> <td>No. 4</td> <td>90</td> <td>100</td> </tr> <tr> <td>No. 8</td> <td>70</td> <td>100</td> </tr> <tr> <td>No. 16</td> <td>40</td> <td>95</td> </tr> <tr> <td>No. 30</td> <td>15</td> <td>70</td> </tr> <tr> <td>No. 40</td> <td>5</td> <td>55</td> </tr> <tr> <td>No. 100</td> <td>0</td> <td>15</td> </tr> <tr> <td>No. 200</td> <td>0</td> <td>5</td> </tr> </tbody> </table> <p>All sands complying with ASTM C33, <i>Standard Specification for Concrete Aggregates</i>, for fine aggregate also comply with the above gradation requirements.</p>	Sieve Size	Percent Passing (by weight)		Min.	Max.	3/8 inch	100	100	No. 4	90	100	No. 8	70	100	No. 16	40	95	No. 30	15	70	No. 40	5	55	No. 100	0	15	No. 200	0	5
	Sieve Size		Percent Passing (by weight)																											
Min.		Max.																												
3/8 inch	100	100																												
No. 4	90	100																												
No. 8	70	100																												
No. 16	40	95																												
No. 30	15	70																												
No. 40	5	55																												
No. 100	0	15																												
No. 200	0	5																												
<b>Sandy Loam Soil</b>	<p><i>Quality:</i> Sandy loam shall be free of wood, waste, and coatings such as carbonate, stone dust, or other deleterious material. All aggregate passing the No. 200 sieve size shall be non-plastic.</p> <p><i>Texture:</i> Based on ASTM D422, sandy loam shall comply with the following specifications by weight:</p> <ul style="list-style-type: none"> <li>A. 50-74 percent sand</li> <li>B. 0-48 percent silt</li> <li>C. 2-15 percent clay</li> </ul>																													

BSM Component	Description																																																																																												
<b>Compost Soil</b>	<p><b>Quality:</b> Compost shall be well-decomposed, stable, weed-free organic matter source and shall be derived from waste materials such as wood waste, yard debris, or other organic materials. Compost shall not be derived from waste that includes manure or biosolids. Compost shall have a soil-like odor and be dark brown in color. Compost exhibiting a sour or putrid smell, containing recognizable grass or leaves, or measuring over 120 degrees Fahrenheit upon delivery or rewetting is unacceptable.</p>																																																																																												
	<p><b>Source:</b> Compost shall be produced from a facility inspected and regulated by the local enforcement agency for CalRecycle. Upon request, the past three inspection reports shall be submitted to verify testing compliance with CalRecycle Title 14 and EPA 40 CFS 503.</p>																																																																																												
	<p><b>Texture:</b> Compost shall be analyzed by a qualified lab using No. 200 and 1/2-inch sieves and meet the following gradation:</p> <table border="1"> <thead> <tr> <th rowspan="2">Sieve Size</th> <th colspan="2">Percent Passing (by weight)</th> </tr> <tr> <th>Min.</th> <th>Max.</th> </tr> </thead> <tbody> <tr> <td>1/2 inch</td> <td>97</td> <td>100</td> </tr> <tr> <td>No. 200</td> <td>0</td> <td>5</td> </tr> </tbody> </table>	Sieve Size	Percent Passing (by weight)		Min.	Max.	1/2 inch	97	100	No. 200	0	5																																																																																	
	Sieve Size		Percent Passing (by weight)																																																																																										
		Min.	Max.																																																																																										
	1/2 inch	97	100																																																																																										
	No. 200	0	5																																																																																										
	<p><b>Parameters:</b> Compost should comply with the following requirements:</p> <table border="1"> <thead> <tr> <th>Parameter</th> <th>Method</th> <th>Requirement</th> <th>Units</th> </tr> </thead> <tbody> <tr> <td>Bulk Density</td> <td>-</td> <td>400-600</td> <td>dry lbs/cubic yd</td> </tr> <tr> <td>Moisture Content</td> <td>Gravimetric</td> <td>30% - 60%</td> <td>Dry solids</td> </tr> <tr> <td>Organic Matter</td> <td>ASTM F 1647 Standard Test Methods for Organic Matter Content of Athletic Field Rootzone Mixes or Testing Methods for the Examination of Compost and Composting (TMECC) 05.07A, "Loss-on-Ignition Organic Matter Method."</td> <td>65% - 75%</td> <td>Dry weight</td> </tr> <tr> <td>pH</td> <td>Saturation Paste</td> <td>6.0 – 8.0</td> <td></td> </tr> <tr> <td>Carbon to Nitrogen Ratio</td> <td>-</td> <td>15:1 to 25:1</td> <td></td> </tr> <tr> <td>Maturity/Stability</td> <td>Solvita®</td> <td>&gt;5</td> <td>Index value</td> </tr> <tr> <td colspan="4"><b>Metals</b></td> </tr> <tr> <td>Arsenic</td> <td></td> <td>&lt;20</td> <td>mg/kg dry weight</td> </tr> <tr> <td>Cadmium</td> <td></td> <td>&lt;10</td> <td>mg/kg dry weight</td> </tr> <tr> <td>Chromium</td> <td></td> <td>&lt;600</td> <td>mg/kg dry weight</td> </tr> <tr> <td>Copper</td> <td></td> <td>&lt;750</td> <td>mg/kg dry weight</td> </tr> <tr> <td>Lead</td> <td></td> <td>&lt;150</td> <td>mg/kg dry weight</td> </tr> <tr> <td>Mercury</td> <td></td> <td>&lt;8</td> <td>mg/kg dry weight</td> </tr> <tr> <td>Nickel</td> <td></td> <td>&lt;210</td> <td>mg/kg dry weight</td> </tr> <tr> <td>Selenium</td> <td></td> <td>&lt;18</td> <td>mg/kg dry weight</td> </tr> <tr> <td>Zinc</td> <td></td> <td>&lt;1400</td> <td>mg/kg dry weight</td> </tr> <tr> <td colspan="4"><b>Pathogens</b></td> </tr> <tr> <td>Salmonella</td> <td></td> <td>&lt;3</td> <td>MPN per 4 g</td> </tr> <tr> <td>Fecal Coliform</td> <td></td> <td>&lt;1000</td> <td>MPN per 1 g</td> </tr> <tr> <td colspan="4"><b>Inert Material/Physical Contaminants</b></td> </tr> <tr> <td>Plastic, Metal, and Glass</td> <td></td> <td>&lt;1%</td> <td>By weight</td> </tr> <tr> <td>Sharps (% &gt;4 mm)</td> <td></td> <td>0%</td> <td>By weight</td> </tr> </tbody> </table>	Parameter	Method	Requirement	Units	Bulk Density	-	400-600	dry lbs/cubic yd	Moisture Content	Gravimetric	30% - 60%	Dry solids	Organic Matter	ASTM F 1647 Standard Test Methods for Organic Matter Content of Athletic Field Rootzone Mixes or Testing Methods for the Examination of Compost and Composting (TMECC) 05.07A, "Loss-on-Ignition Organic Matter Method."	65% - 75%	Dry weight	pH	Saturation Paste	6.0 – 8.0		Carbon to Nitrogen Ratio	-	15:1 to 25:1		Maturity/Stability	Solvita®	>5	Index value	<b>Metals</b>				Arsenic		<20	mg/kg dry weight	Cadmium		<10	mg/kg dry weight	Chromium		<600	mg/kg dry weight	Copper		<750	mg/kg dry weight	Lead		<150	mg/kg dry weight	Mercury		<8	mg/kg dry weight	Nickel		<210	mg/kg dry weight	Selenium		<18	mg/kg dry weight	Zinc		<1400	mg/kg dry weight	<b>Pathogens</b>				Salmonella		<3	MPN per 4 g	Fecal Coliform		<1000	MPN per 1 g	<b>Inert Material/Physical Contaminants</b>				Plastic, Metal, and Glass		<1%	By weight	Sharps (% >4 mm)		0%	By weight
	Parameter	Method	Requirement	Units																																																																																									
	Bulk Density	-	400-600	dry lbs/cubic yd																																																																																									
Moisture Content	Gravimetric	30% - 60%	Dry solids																																																																																										
Organic Matter	ASTM F 1647 Standard Test Methods for Organic Matter Content of Athletic Field Rootzone Mixes or Testing Methods for the Examination of Compost and Composting (TMECC) 05.07A, "Loss-on-Ignition Organic Matter Method."	65% - 75%	Dry weight																																																																																										
pH	Saturation Paste	6.0 – 8.0																																																																																											
Carbon to Nitrogen Ratio	-	15:1 to 25:1																																																																																											
Maturity/Stability	Solvita®	>5	Index value																																																																																										
<b>Metals</b>																																																																																													
Arsenic		<20	mg/kg dry weight																																																																																										
Cadmium		<10	mg/kg dry weight																																																																																										
Chromium		<600	mg/kg dry weight																																																																																										
Copper		<750	mg/kg dry weight																																																																																										
Lead		<150	mg/kg dry weight																																																																																										
Mercury		<8	mg/kg dry weight																																																																																										
Nickel		<210	mg/kg dry weight																																																																																										
Selenium		<18	mg/kg dry weight																																																																																										
Zinc		<1400	mg/kg dry weight																																																																																										
<b>Pathogens</b>																																																																																													
Salmonella		<3	MPN per 4 g																																																																																										
Fecal Coliform		<1000	MPN per 1 g																																																																																										
<b>Inert Material/Physical Contaminants</b>																																																																																													
Plastic, Metal, and Glass		<1%	By weight																																																																																										
Sharps (% >4 mm)		0%	By weight																																																																																										



# Appendix J. Local Agency Plant Selection Guidance

---

THIS PAGE INTENTIONALLY LEFT BLANK

## Appendix J Local Agency Plant Selection Guidance

---

Some agencies within the Stormwater Quality Partnership have specific plant lists included in their agency guidelines; other agencies rely on project applicants to develop plant lists based on specific criteria. For those agencies that have approved plant lists or other specific guidelines, links are provided below.

### City of Citrus Heights

Landscape Guidelines: <https://www.citrusheights.net/DocumentCenter/View/4199>

### City of Elk Grove

Chapter 23.54 Landscaping, Section 23.54.040 Landscape development standards

(<http://www.codepublishing.com/CA/ElkGrove/html/ElkGrove23/ElkGrove2354.html#23.54.040>)

**Plant Type.** Landscape planting shall include drought-tolerant, ornamental, and native species (especially along natural corridors), shall complement the architectural design of structures on the site, and shall be suitable for the soil and climatic conditions specific to the site.

### City of Galt

Landscape Design Guidelines:

<http://www.ci.galt.ca.us/home/showdocument?id=15839>

### City of Rancho Cordova

Refer to the UC Davis Arboretum ([www.arboretum.ucdavis.edu](http://www.arboretum.ucdavis.edu)) for a list of 100 affordable, water-wise plant options that thrive in California's Mediterranean climate.

### City of Sacramento

River-Friendly Landscape Plant List:

<http://www.cityofsacramento.org/-/media/Corporate/Files/DOU/Conservation/Cover-Letter-Plant-List.pdf?la=en>

### Other References

Alameda County Stormwater Technical Guidance

<https://www.cleanwaterprogram.org/c3-guidance-table.html>

Appendix B includes a table of recommended plant types and corresponding storm water measures.

California Native Plant Society

Sac Valley's Drought-Tolerant, California Native Plant List

[https://sacvalleycnps.org/index.php?option=com\\_content&view=article&id=71&Itemid=237](https://sacvalleycnps.org/index.php?option=com_content&view=article&id=71&Itemid=237)

THIS PAGE INTENTIONALLY LEFT BLANK

# B

## Plant List and Planting Guidance for Landscape- Based Stormwater Measures

### Table of Contents

B.1	Introduction	1
B.2	General Recommendations	2
B.3	Plants for Stormwater Measures	3
B.4	Planting Specifications	10
B.5	Monitoring and Maintenance	13
B.6	Bay-Friendly Landscaping and Integrated Pest Management	15
B.7	Nursery Sources for Native Plants	19
	References	20

### B.1 Introduction

The purpose of this appendix is to provide guidance on the planting techniques and selection of appropriate plant materials for the stormwater measures described in this handbook.

The plant lists described in this appendix are not prescriptive, but should serve as a guide. In selecting plant materials, it is important to consider factors that influence plant establishment and success, such as microclimate, type of soil, water availability, proximity to saltwater and exposure to sun. Numerous resources are available to assist in selecting appropriate plant species in Alameda County, including Sunset's *Western Garden Book* and the East Bay Municipal Utility District's *Plants and Landscapes for Summer-Dry Climates of the San Francisco Bay Region*.

In addition, the function of the individual stormwater measure should be carefully considered when selecting plant materials. Factors to be considered include inundation period, expected flow of water, and access and maintenance requirements.

## B.2 General Recommendations

**Avoid the use of invasive species.** In selecting plants for stormwater measures, the use of invasive species should be avoided. A complete list of invasive plants can be found at [www.cal-ipc.org](http://www.cal-ipc.org), the California Invasive Plant Council's Invasive Plant Inventory.

**Minimize or eliminate the use of irrigated turf.** Effort should be made to minimize the use of irrigated turf, which has higher maintenance requirements and greater potential for polluted runoff.

**Select California natives and/or drought tolerant plants.** Planting appropriate, drought tolerant California natives or Mediterranean plants reduces water consumption for irrigations, and reduces mowing, fertilizing, and spraying. For the purposes of the plant list on the following pages, "drought tolerant" refers to plants that meet the following criteria:

- Are identified as drought tolerant as follows: California Native Plants for the Garden (Borstein, et al.).
- Are identified as requiring occasional or infrequent irrigation in Borstein, et al., or Plants and Landscapes for Summer Dry Climates (EBMUD).
- Are identified as requiring no summer water in EBMUD.
- Are identified as requiring little or no water in the Sunset Western Garden Book.
- Are identified as requiring low or very low irrigation in the Guide to Estimating Irrigation Water Needs of Landscape Plantings in California (University of California Cooperative Extension).

Plants not listed in any of the above references will require that the design professional base selection upon successful experience with species on previous projects under similar horticultural conditions.

**Site-specific Factors.** Given Alameda County spans several Sunset climate zones, with variable humidity, heat, frost, and wind factors, as well as varying soil characteristics, plants need to be selected with an understanding of specific climate and microclimate conditions, and grouped in appropriate hydrozones.

**Supplemental watering needs.** Many plants listed as drought tolerant per the above references may require more supplemental watering in fast-draining, engineered soils.

The plant lists described in this appendix are not prescriptive, but should **serve as a guide**. In selecting plant materials, it is important to consider factors that influence plant establishment and success, such as microclimate, type of soil, water availability, proximity to saltwater and exposure to sun.

## B.3 Plants for Stormwater Measures

Plants play an important role in the function of landscape-based stormwater treatment measures:

- **Infiltration and evapotranspiration.** Plants aid in the reduction of stormwater runoff by both increasing infiltration, and by returning water to the atmosphere through evapotranspiration.
- **Sedimentation.** Some stormwater treatment measures, such as vegetated swales and vegetated buffer strips, are designed to remove coarse solids through sedimentation that is aided by dense, low-growing vegetation.
- **Pollutant trapping.** Vegetation helps to prevent the resuspension of pollutants associated with sediment particles. It is essential that pollutants removed during small storms are not remobilized during large storms.
- **Phytoremediation.** Plants for stormwater treatment measures are important for their role in phytoremediation, the uptake of nutrients and the ability to neutralize pollutants.
- **Soil stabilization.** As in any landscaped area, established plantings help control soil erosion. This is important both to keep sediment out of stormwater and to retain the surface soils, which help to remove pollutants from infiltrated runoff.
- **Aesthetic benefits.** Plants within or adjacent to stormwater facilities provide an aesthetic benefit.

Plants suitable for use in stormwater treatment measures are organized according to the following categories:

- **Emergent** refers to those species which occur on saturated soils or on soils covered with water for most of the growing season. The foliage of emergent aquatics is partly or entirely borne above the water surface.
- **Grasses** refer to those species that are monocotyledonous plants with slender-leaved herbage found in the in the Family Poaceae.
- **Herbaceous** refers to those species with soft upper growth rather than woody growth. Some species will die back to the roots at the end of the growing season and grow again at the start of the next season. Annuals, biennials and perennials may be herbaceous.
- **Shrub** is a horticultural distinction that refers to those species of woody plants which are distinguished from trees by their multiple stems and lower height. A large number of plants can be either shrubs or trees, depending on the growing conditions they experience.
- **Tree** refers to those species of woody plants with one main trunk and a rather distinct and elevated head.

Plants suitable for use in stormwater treatment measures are listed in two ways. First, a comprehensive list of all recommended plant species is provided in Table B-1, which lists the plants in alphabetical order by Latin name, in the categories described above. The columns in Table B-1 indicate stormwater treatment measures for which each plant species may be suitable. Following Table B-1 are brief descriptions of the stormwater measures for which technical guidance is included in this handbook, including the suitable plantings from Table B-1.

**Invasive species.** Under no circumstances shall any plants listed as invasive under [www.cal-ipc.org/paf](http://www.cal-ipc.org/paf) be specified.



Table B-1 Plant List for Stormwater Measures

		Bioretention Area - including linear treatment measure	Flow-Through Planters	Tree Well Filters <sup>2</sup>	Vegetated Buffer Strip	Infiltration Trench	Extended Detention Basin - bioretreatment soil	Extended Detention Basin - non-bioretreatment soil	Turf Block Pavers	Green Roof - extensive	Green Roof - intensive	California Native	Drought Tolerant <sup>1</sup>
<b>Emergent Species</b>													
<i>Artemisia douglasiana</i>	mugwort						✓	✓				✓	
<i>Carex barbarae</i>	Santa Barbara sedge			✓			✓	✓		✓	✓		✓
<i>Carex densa</i>	dense sedge						✓	✓				✓	
<i>Carex obnupta</i>	slough sedge						✓	✓				✓	
<i>Eleocharis macrostachya</i>	creeping spikerush				✓		✓	✓				✓	
<i>Hydrocotyle ranunculoides</i>	marsh pennywort	✓						✓				✓	
<i>Juncus balticus</i> <sup>1</sup>	baltic rush						✓	✓				✓	
<i>Juncus bufonius</i>	toad rush						✓	✓				✓	
<i>Juncus effusus</i> <sup>1</sup>	Pacific rush						✓	✓				✓	
<i>Juncus leseurii</i>	common rush						✓	✓				✓	
<i>Juncus mexicanus</i>	Mexican rush						✓	✓				✓	
<i>Juncus patens</i>	blue rush	✓	✓		✓	✓	✓	✓			✓	✓	
<i>Juncus xiphioides</i>	iris-leaved rush						✓	✓				✓	
<i>Limonium californicum</i>	Marsh rosemary						✓	✓				✓	✓
<i>Phragmites</i> spp.	common reeds						✓	✓					
<i>Scirpus actutus</i>	tule						✓	✓				✓	
<i>Scirpus americanus</i> <sup>1</sup>	three square	✓					✓	✓				✓	
<i>Scirpus californicus</i> <sup>1</sup>	california bulrush						✓	✓				✓	
<i>Spartina foliosa</i>	California cordgrass						✓	✓				✓	
<i>Typha angustifolia</i>	narrowleaf cattail						✓	✓				✓	
<i>Typha latifolia</i>	cattail						✓	✓				✓	
<b>Grass Species</b>													
<i>Agrostis exarata</i>	spike bentgrass						✓	✓	✓			✓	
<i>Alopecurus aequalis</i>	shortawn foxtail						✓	✓				✓	
<i>Alopecurus saccatus</i>	Pacific foxtail						✓	✓				✓	
<i>Aristida purpurea</i>	Purple three-awn	✓	✓		✓						✓	✓	✓
<i>Carex pansa</i>	California meadow sedge			✓	✓		✓	✓	✓	✓	✓	✓	✓
<i>Carex praegracilis</i>	clustered field sedge						✓	✓				✓	
<i>Carex divulsa (tumulicola)</i>	Berkeley sedge							✓				✓	
<i>Chondropetalum tectorum</i>	cape rush	✓	✓		✓	✓	✓	✓			✓		✓
<i>Danthonia californica</i>	California oatgrass						✓	✓				✓	
<i>Deschampsia cespitosa</i> <sup>1</sup>	tufted hairgrass	✓			✓	✓	✓	✓			✓	✓	✓
<i>Deschampsia cespitosa ssp. holciformis</i>	Pacific hairgrass	✓			✓	✓	✓	✓			✓	✓	✓
<i>Deschampsia danthonioides</i>	annual hairgrass						✓	✓			✓	✓	
<i>Distichlis spicata</i>	salt grass						✓	✓				✓	
<i>Eleocharis palustris</i>	creeping spikerush						✓	✓				✓	
<i>Elymus glaucus</i>	blue wild rye	✓			✓			✓		✓	✓	✓	✓
<i>Festuca californica</i>	California fescue	✓	✓	✓	✓						✓	✓	✓
<i>Festuca idahoensis</i>	Idaho fescue		✓	✓	✓				✓		✓	✓	
<i>Festuca rubra</i> <sup>1</sup>	red fescue		✓	✓	✓				✓		✓	✓	✓
<i>Festuca rubra 'molate'</i>	Molate fescue		✓	✓	✓				✓		✓	✓	✓
<i>Hordeum brachyantherum</i> <sup>1</sup>	meadow barley	✓			✓		✓	✓				✓	✓
<i>Leymus triticoides</i>	creeping wildrye	✓			✓			✓			✓	✓	✓
<i>Linum usitatissimum</i> <sup>1</sup>	flax	✓	✓										✓
<i>Lolium perenne</i> <sup>1</sup>	ryegrass	✓	✓		✓								✓
<i>Melica californica</i>	California melic				✓							✓	✓
<b>Grass Species cont'd</b>													
<i>Melica imperfecta</i>	coast range melic	✓	✓		✓							✓	✓
<i>Muhlenbergia rigens</i>	deergrass	✓	✓		✓	✓	✓	✓			✓	✓	✓

<sup>1</sup> Denotes riparian species with limited drought tolerance

<sup>2</sup> Denotes species with phytoremediation capabilities

<sup>3</sup> Non-tree species to be used only with adequate planting surface and when infiltration rates are 5-10 inches/hour

Table B-1 Plant List for Stormwater Measures

		Bioretention Area - including linear treatment measure	Flow-Through Planters	Tree Well Filters <sup>2</sup>	Vegetated Buffer Strip	Infiltration Trench	Extended Detention Basin - bioretention soil	Extended Detention Basin - non-bioretention soil	Turf Block Pavers	Green Roof - extensive	Green Roof - intensive	California Native	Drought Tolerant <sup>1</sup>
<i>Nasella pulchra</i>	purple needlegrass	✓		✓	✓						✓	✓	✓
<i>Nassella lepida</i>	Foothill needlegrass			✓	✓						✓	✓	✓
<i>Panicum coloratum</i> <sup>1</sup>	kleingrass	✓	✓		✓	✓							
<i>Panicum virgatum</i> <sup>1</sup>	switchgrass	✓	✓		✓	✓							
<i>Phalaris californica</i>	California canarygrass	✓			✓	✓							
<i>Pleuropogon californicus</i>	semaphore grass				✓	✓						✓	
<i>Sisyrinchium bellum</i>	blue-eyed grass		✓		✓	✓				✓		✓	✓
<i>Sisyrinchium douglasii</i>	purple-eyed grass				✓	✓				✓		✓	

**Herbaceous Species**

<i>Achillea millefolium</i> <sup>1</sup>	common yarrow		✓	✓	✓					✓	✓	✓	✓
<i>Allium</i> spp.	wild onion	✓	✓		✓					✓	✓		
<i>Anthemis nobilis</i> ( <i>Chamaemelum nobile</i> )	chamomile			✓					✓				✓
<i>Armeria maritima</i>	sea pink		✓	✓	✓				✓	✓	✓	✓	✓
<i>Clarkia</i> spp.	Clarkia	✓			✓				✓	✓	✓	✓	✓
<i>Epilobium densiflorum</i>	dense spike-primrose	✓	✓		✓	✓						✓	✓
<i>Eriogonum latifolium</i>	coast buckwheat			✓	✓							✓	✓
<i>Eriogonum fasciculatum</i>	flattop buckwheat			✓	✓							✓	✓
<i>Eschscholzia californica</i>	California poppy	✓	✓		✓			✓	✓	✓	✓	✓	✓
<i>Layia platyglossa</i>	tidy tips				✓				✓	✓	✓	✓	✓
<i>Limonium californicum</i>	marsh rosemary	✓	✓		✓	✓	✓					✓	✓
<i>Linanthus</i> spp.	Linanthus	✓			✓				✓	✓	✓	✓	✓
<i>Lotus scoparius</i>	deerweed	✓			✓				✓	✓	✓	✓	✓
<i>Mimulus aurantiacus</i>	common monkeyflower	✓	✓		✓					✓	✓	✓	✓
<i>Mimulus cardinalis</i>	scarlet monkeyflower	✓	✓	✓	✓		✓	✓		✓	✓		
<i>Monardella</i> spp.	coyote mint	✓			✓							✓	✓
<i>Nepeta</i> spp.	catmint	✓		✓	✓					✓	✓	✓	✓
<i>Penstemon</i> spp.	bearded tongue	✓		✓	✓					✓	✓	✓	✓
<i>Sedum</i> spp.	stonecrop				✓				✓	✓			✓
<i>Sempervivum</i> spp.	hen and chicks				✓				✓	✓			✓
<i>Solidago</i> spp. <sup>1</sup>	goldenrod		✓		✓				✓	✓			
<i>Thymus pseudolanuginosus</i>	woolly thyme	✓	✓	✓	✓			✓	✓	✓			
<i>Vigna unguiculata</i> <sup>1</sup>	cowpea		✓		✓					✓			

**Shrub Species**

<i>Adenostoma fasciculatum</i>	chamise				✓						✓	✓	✓
<i>Arctostaphylos densiflora</i> 'McMinn'	manzanita 'McMinn'	✓	✓		✓						✓	✓	✓
<i>Arctostaphylos manzanita</i>	common manzanita		✓		✓						✓	✓	✓
<i>Arctostaphylos uva-ursi</i> 'Emerald Carpet'	manzanita 'Emerald Carpet'	✓	✓	✓	✓						✓	✓	✓
<i>Baccharis pilularis</i> 'Twin Peaks'	coyote brush prostrate	✓	✓	✓	✓						✓	✓	✓
<i>Baccharis salicifolia</i>	mulefat				✓		✓	✓				✓	
<i>Buddleia</i> spp.	butterfly bush	✓			✓								✓
<i>Calycanthus occidentalis</i>	Spicebush	✓	✓		✓	✓					✓	✓	✓
<i>Carpenteria californica</i>	bush anemone	✓	✓		✓							✓	✓

**Shrub Species cont'd**

<i>Ceanothus hearstiorum</i>	ceanothus	✓			✓						✓	✓	✓
<i>Ceanothus</i> spp.	ceanothus	✓			✓						✓	✓	✓
<i>Cercocarpus betuloides</i>	mountain mahogany				✓							✓	✓
<i>Cistus</i> spp.	rockrose				✓								✓
<i>Cornus sericea</i> (same as <i>C. stolonifera</i> )	western dogwood	✓	✓		✓	✓	✓	✓					
<i>Garrya elliptica</i>	coast silk tassel		✓		✓					✓	✓	✓	✓
<i>Echium candicans</i>	pride-of-madeira		✓		✓								✓
<i>Heteromeles arbutifolia</i>	toyon	✓	✓		✓					✓	✓	✓	✓
<i>Holodiscus</i> spp.	oceanspray	✓			✓						✓	✓	✓
<i>Lavandula</i> spp.	lavender		✓	✓	✓						✓	✓	✓
<i>Lavatera</i> spp.	tree mallow				✓								✓

<sup>\*</sup> Denotes riparian species with limited drought tolerance

<sup>1</sup> Denotes species with phytoremediation capabilities

<sup>2</sup> Non-tree species to be used only with adequate planting surface and when infiltration rates are 5-10 inches/hour

Table B-1 Plant List for Stormwater Measures

		Bioretention Area - including linear treatment measure	Flow-Through Planters	Tree Well Filters <sup>2</sup>	Vegetated Buffer Strip	Infiltration Trench	Extended Detention Basin - bioretention soil	Extended Detention Basin - non-bioretention soil	Turf Block Pavers	Green Roof - extensive	Green Roof - intensive	California Native	Drought Tolerant <sup>1</sup>
<i>Lepechinia calycina</i>	pitcher sage			✓								✓	✓
<i>Lupinus albifrons</i>	bush lupine			✓								✓	✓
<i>Mahonia aquifolium</i>	Oregon grape	✓	✓	✓							✓	✓	✓
<i>Mahonia repens</i>	creeping Oregon grape	✓	✓	✓	✓						✓	✓	✓
<i>Myrica californica</i>	Pacific wax myrtle			✓							✓	✓	✓
<i>Physocarpus capitatus</i>	Pacific ninebark	✓		✓		✓	✓				✓	✓	
<i>Pittosporum tobira</i>	mock orange		✓	✓									✓
<i>Prunus ilicifolia</i>	holleyleaf cherry			✓	✓							✓	✓
<i>Rhamnus Californica</i>	coffeeberry	✓	✓	✓							✓	✓	✓
<i>Rhus integrifolia</i>	lemonade berry			✓								✓	✓
<i>Ribes aureum</i>	golden currant	✓	✓	✓	✓							✓	✓
<i>Ribes malvaceum</i>	chaparral currant			✓								✓	✓
<i>Ribes sanguineum</i>	red-flowering currant			✓								✓	✓
<i>Rosa californica</i>	California wild rose	✓	✓	✓	✓							✓	✓
<i>Rubus parviflorus</i>	thimbleberry	✓	✓	✓	✓							✓	
<i>Rubus spectabilis</i>	salmonberry	✓	✓	✓	✓								
<i>Rubus ursinus</i>	California blackberry	✓		✓								✓	✓
<i>Salvia brandegii</i>	black sage			✓								✓	✓
<i>Salvia clevelandii</i>	Cleveland sage	✓		✓								✓	✓
<i>Salvia leucophylla</i>	purple sage	✓		✓								✓	✓
<i>Salvia mellifera</i>	black sage			✓								✓	✓
<i>Salvia sonomensis</i>	creeping sage	✓	✓	✓	✓							✓	✓
<i>Sambucus mexicana</i>	elderberry	✓	✓	✓								✓	✓
<i>Santolina spp.</i>	santolina	✓	✓	✓								✓	✓
<i>Symphoricarpos albus</i>	snowberry		✓	✓								✓	✓
<i>Stachys spp.</i>	lamb's ear			✓	✓				✓	✓		✓	✓
<i>Styrax officinalis redivivus</i>	California snowdrop	✓		✓								✓	✓
<i>Trichostema spp.</i>	wooly blue curls	✓		✓							✓	✓	✓
<i>Vaccinium ovatum</i>	evergreen huckleberry	✓	✓	✓								✓	
<i>Zauschneria californica (Epilobium c.)</i>	California fuchsia		✓	✓							✓	✓	✓
<b>Tree Species</b>													
<i>Acer circinatum</i>	Vine Maple	✓		✓	✓	✓					✓	✓	
<i>Acer macrophyllum*</i>	big leaf maple	✓		✓								✓	
<i>Acer negundo* v. Californicum</i>	box elder	✓		✓	✓	✓	✓					✓	
<i>Aesculus californica</i>	buckeye			✓								✓	✓
<i>Alnus rhombifolia *</i>	white alder	✓		✓	✓	✓	✓					✓	
<i>Alnus rubra*</i>	red alder	✓		✓	✓	✓	✓					✓	
<i>Arbutus menziesii</i>	Madrone			✓								✓	✓
<i>Arbutus unedo</i>	strawberry tree			✓						✓		✓	
<i>Betula nigra</i>	river birch	✓		✓	✓	✓							
<i>Calocedrus decurrens</i>	incense cedar			✓								✓	
<i>Celtis occidentalis</i>	common hackberry			✓									✓
<i>Cercidium floridum</i>	Blue palo verde			✓								✓	✓
<i>Cercis occidentalis</i>	redbud			✓						✓	✓	✓	✓
<i>Chionanthus retusus</i>	Chinese fringe tree			✓									

\* Denotes riparian species with limited drought tolerance

<sup>1</sup> Denotes species with phytoremediation capabilities

<sup>2</sup> Non-tree species to be used only with adequate planting surface and when infiltration rates are 5-10 inches/hour

Table B-1 Plant List for Stormwater Measures

		Bioretention Area - including linear treatment measure	Flow-Through Planters	Tree Well Filters <sup>2</sup>	Vegetated Buffer Strip	Infiltration Trench	Extended Detention Basin - bioretreatment soil	Extended Detention Basin - non-bioretreatment soil	Turf Block Pavers	Green Roof - extensive	Green Roof - intensive	California Native	Drought Tolerant <sup>1</sup>
<i>Corylus cornuta v. Californica</i>	California hazelnut	✓		✓	✓							✓	✓
<i>Crataegus</i>	Hawthorn			✓						✓			✓
<i>Fraxinus latifolia</i>	Oregon ash	✓		✓	✓	✓	✓					✓	
<i>Geijera parviflora</i>	Australian willow				✓								
<i>Lagerstroemia spp.</i>	crepe myrtle				✓					✓			✓
<i>Lyanthamnus floribundus asplendifolius</i>	Catalina Ironwood				✓							✓	✓
<i>Morus alba (fruitless var.)<sup>1</sup></i>	white mulberry				✓								
<i>Platanus acerifolia</i>	london plane tree				✓								✓
<i>Platanus racemosa*</i>	sycamore	✓			✓		✓					✓	
<i>Populus fremontii*<sup>1</sup></i>	Fremont's cottonwood	✓		✓	✓	✓						✓	
<i>Prunus, spp.</i>	plum				✓								✓
<i>Quercus agrifolia</i>	California live oak				✓							✓	✓
<i>Quercus kelloggii</i>	California black oak				✓							✓	✓
<i>Quercus lobata</i>	valley oak	✓			✓							✓	✓
<i>Quercus palustris</i>	pin oak				✓								
<i>Quercus virginiana</i>	Southern live oak			✓									
<i>Salix laevigata<sup>1</sup></i>	red willow	✓			✓	✓	✓	✓				✓	
<i>Salix lasiolepis<sup>1</sup></i>	arroyo willow	✓			✓	✓	✓	✓				✓	
<i>Salix lucida ssp. lasiandra<sup>1</sup></i>	shining willow	✓			✓	✓	✓	✓				✓	
<i>Sequoia sempervirens</i>	coast redwood				✓		✓	✓				✓	
<i>Umbellularia californica</i>	California bay				✓							✓	

\* Denotes riparian species with limited drought tolerance

<sup>1</sup> Denotes species with phytoremediation capabilities

<sup>2</sup> Non-tree species to be used only with adequate planting surface and when infiltration rates are 5-10 inches/hour

A brief paragraph describing each stormwater measure is provided below, including the key factors that should influence planting techniques and plant selection. For suitable plantings, please refer to Table B-1.

#### Bioretention Area (including linear treatment measures)

Bioretention areas are intended to act as filters with plants. Plants in bioretention areas help with phytoremediation and infiltration. Therefore, nutrient uptake and the ability to neutralize pollutants are priorities for species selection. Plants for these areas should be able to withstand periods of inundation as well as extended periods of drought. Emergent, grass and herbaceous species can be planted in the bioretention area, while shrub and tree species should be concentrated on the outer edges. Grasses can also be planted along the exterior to slow the velocity of flow and allow the sedimentation of coarse solids, which helps minimize clogging of the bioretention area. Supplemental irrigation will be necessary to maintain emergent species during extremely dry conditions.

#### Flow-through planter

Plant species for flow-through planters will depend on the size of the planter. Shrubs and trees should be planted in planters only when there is sufficient space. Recommended minimum soil depth for shrubs is 18", and for small trees is 36". Plant species should be adapted to well-drained soils. Irrigation is typically required, but selecting plants adapted to extended dry periods can reduce irrigation requirements.

#### Tree well filter

Trees and shrubs planted in tree well filters should be an appropriate size for the space provided. Because plant roots are confined to the container, it is recommended that small trees and shrubs with shallow, fibrous roots be planted in the tree well filter. Provided that site conditions allow, it may be possible to work with the manufacturer to design a container that would allow for the planting of larger trees or shrubs. Plants for tree well filters should be tolerant of frequent, but temporary periods of inundation as well as adapted to extremely well-drained soils. Species with the ability to neutralize contaminants are preferred.

#### Vegetated buffer strips

Vegetated buffer strips should be designed to function and appear as natural vegetated areas adjacent to development. They treat surface runoff from adjacent impervious areas so a variety of trees, shrubs, and grass and herbaceous species should be included in order to maximize water and nutrient uptake, as well as to retain sediment.

#### Infiltration Trench

An infiltration trench is an aggregate filled trench that receives and stores stormwater runoff in the void spaces between the aggregate and allows it to infiltrate into the surrounding soil. Vegetated filter strips of grass species on either side of the trench can slow and pre-treat the runoff while the trench can physically remove fine sediment and other suspended solids.

#### Extended Detention Basin

Extended detention basins are intended to capture and detain water for much longer periods (up to 5 days) than bioretention areas. They are designed to drain completely between storms. Plants in extended detention basins increase pollutant removal and assist with soil stabilization;

therefore nutrient uptake and the ability to neutralize pollutants are priorities for species selection. Because extended detention basins are intended to capture and move large quantities of water, trees should not be planted in the basins, and shrubs are typically not specified for extended detention basins. Subject to approval by the municipality, trees and shrubs may be included on the outer perimeter (top of bank), provided that they do not interfere with detention. Species should be adapted to periodic inundation and saturation and extended periods of dry conditions. Emergent, grass and herbaceous species for extended detention basins should consist of species that are able to withstand extended periods of inundation. Supplemental irrigation will be necessary to maintain emergent species during extremely dry conditions. Extended detention basins typically have typically not been constructed with special soil, and beginning December 1, 2011, basins designed without biotreatment soil (having a long-term infiltration rate of 5 to 10 inches per hour) may not be used as stand-alone treatment measures, although they could be used as part of a treatment train, along with biotreatment measures (more information in Section 6.6). Table B-1 includes two planting lists for extended detention basins: one for basins designed WITH biotreatment soil, and another for basins designed WITHOUT biotreatment soil.

#### Pervious paving – Turf Block Pavers

Some pervious paving systems can be planted with grass or herbaceous species in order to assist with erosion prevention as well as promote infiltration and pollutant uptake. Plant species should be tolerant of compaction, have the ability to neutralize contaminants, and should not interfere with maintenance and use of the paved surface. Most plant species cannot tolerate frequent vehicular compaction. Therefore, turf block pavers are best suited for areas requiring infrequent access, such as emergency vehicle access routes. Paver manufacturer should be consulted regarding recommended and acceptable plant species.

#### Green roof

A green roof is intended to capture precipitation and roof runoff. Green roofs utilize a lightweight, porous planting substrate as a medium for plant growth. The depth and composition of this substrate is extremely important in determining types of plants that will be successful as part of a green roof system. Intensive green roofs, which can have up to 48" of substrate, can support a wider variety of plant types. The list in Table B-1 is only a sample of plants that could be suitable for an intensive green roof. Please note that shrub species may be used only if the substrate has a minimum depth of 12 inches; a minimum depth of 36 inches is required for planting trees.

Extensive green roofs, which have a depth of 3" to 7" of planting medium, are suitable for a limited number of grass and herbaceous species. These roofs generally require little maintenance and should be designed to succeed with minimal irrigation. In addition to the species listed in Table B-1, pre-vegetated mats can be utilized on extensive green roofs. Information can be found at: [www.thehenryford.org/rouge/leedlivingroof.aspx](http://www.thehenryford.org/rouge/leedlivingroof.aspx).

## B.4 Planting Specifications

Planting plans and specifications must be prepared by a qualified professional and coordinated with other site development details and specifications including earthwork, soil preparation and irrigation (if used). Plans indicating a planting layout, with species composition and density,

should be prepared on a site-specific basis. Reference Alameda County's Bay Friendly Landscaping Guidelines prepared by Rescape California, also known as the Bay-Friendly Landscaping Coalition (available at [www.rescapeca.org](http://www.rescapeca.org)), which outline principles and practices to minimize waste, protect air and water quality, conserve energy and water, and protect natural ecosystems, including:

- Evaluate site and assess the soil;
- Consider potential for fire;
- Select plants for appropriate size upon maturity, do not over-plant;
- Irrigation, if required, should be designed as a high efficiency, water conserving system; and
- Utilize compost (see the specification in the Bay-Friendly Landscaping Guidelines) and mulch to build healthy soils and increase the water holding capacity of the soil.

#### Propagation and Planting Methods

The propagation methods for different species will vary, depending upon type of plant and stormwater adaptation. In general, container stock will be utilized most commonly for greenroofs, flow-through planters, tree well filters, vegetated swales and buffer strips and infiltration trenches. Bioretention areas and extended detention basins will generally utilize native plants available as transplants (plugs), pole cuttings and seed mixes.

**Container Stock.** Planting holes for container stock should be twice as wide and only as deep as the container size. Plant spacing should be determined on a site-specific basis. When planting, the root collar and base of the stem should be 1" above the adjacent soil surface. Soils should be backfilled and tamped down to assure contact with the roots. The planting should be watered-in promptly to promote the settling of soil. If appropriate, container plantings may receive a balanced time-released fertilizer tablet, quantity and placement per manufacturer's recommendation, placed in the planting hole prior to installation of the plant. Planting berms for water retention and mulch shall be used to enhance plant establishment. Trees shall be staked or guyed to provide interim support until established.

**Transplants (Plugs).** Transplanted plant divisions, referred to here as "plugs", should be planted during the fall dormant period, preferably between October 1 and November 15 after first soaking rain. Plugs should be collected from a suitable collection site in the vicinity of the constructed basins. Plugs are clumps of plant roots, rhizomes or tubers combined with associated soil that can be manually removed, or salvaged with an excavator or backhoe. The maximum recommended size is 1 foot x 1 foot. Whole plants or plant divisions can be utilized. The plugs should be from healthy specimens free of insects, weeds and disease. The plugs should be spaced from 1 foot to 6 feet apart, depending on the size of the plug. Smaller plugs can be planted at the minimum distance to promote faster spreading and cover. Larger plugs from cattail and bulrush species should be planted at 3-foot to 6-foot intervals.

To plant a plug, a hole slightly wider than the diameter of the plug should be prepared and the roots system of the plug placed in the hole. Do not over-excavate the hole depth or the plant will settle below grade. A shovel could be used to create the planting hole. Manual planting with a spade is recommended for wet soils. Power augers can be used for creating holes in dry

soils. Alternatively, a trench could be created along the narrow axis of the extended detention basin, and planting material manually placed at specified elevations in relation to the proximity of permanently saturated soils. To plant a plug with an established root system, the base of the stem and top of the root collar should be level with the ground surface. Tubers should be secured to prevent floating. Rhizomes should be placed in the soil with a slight upward angle.

The hole or trench containing the plug(s) should be backfilled with soil and the soil tamped down to assure good soil contact and secure the plug. The vegetative portion of the plant should be cut back to prevent water loss and wilting, and encourage the growth of roots and new shoots. Plugs of wetland plants should be grown in saturated soil. The soil should not be allowed to dry out after planting. Plugs should be planted immediately, when possible. When necessary, plugs can be stored in a cool, moist, shaded location for a maximum of one day. Plants must be thoroughly watered.

**Pole Cuttings.** Pole cuttings should be collected from the 1-year old wood of dormant trees and have a minimum of 5 viable nodes. The parent material should be healthy and free of diseases. The basal area of the pole cutting should be a minimum of one to two inches in diameter; however, the diameter at the base should not exceed 2 inches. The optimum diameter width of the base is 1 inch. The length of the cutting should be a minimum of 2 feet and should not exceed a maximum of 4 feet in length. Generally, 75 percent of the length of the cutting should be planted beneath the soil surface.

Pole cuttings should be collected no more than 2 days prior to planting. Cuttings should be placed in cool water to promote swelling of the nodes. Water should be kept fresh by aeration and/or by daily replacement. The pole cuttings should be placed in a hole approximately 3 feet deep (as determined by the length of the cutting) and backfilled with native soil, or a rich organic medium mixed with native soil. Soil should be tamped down to remove air pockets and assure soil contact with the cutting.

**Seeding.** Seeding should be conducted after plugs, container stock and pole cuttings are installed. Hydroseeding or broadcast method shall be utilized as appropriate for the size and accessibility of the area. The soil surface should be scarified prior to seeding. Do not damage previously planted vegetation. The seeds should be planted in fall, ideally in October.

Seeds should be broadcast or hydroseeded over the specified planting area. With broadcast seeding, the seed should be applied with hand-held spreaders to scarified soil. The soil surface should then be raked to cover the seeds with about one-eighth to one-quarter inch of soil to discourage predation, and tamped or rolled to firm soil surface.

Seeds should be planted at the ratios and rates specified by the supplier. The seed should be free of weeds and diseases. The supplier should provide the certified germination percentage.

#### Water Level Management and Irrigation for Plant Establishment

All newly planted material needs careful attention to watering requirements to ensure proper establishment. As mentioned in the introduction, it is important to select plants based on specific site conditions, which will affect the availability of water for plant use. Also, grouping plants with similar water needs can help reduce irrigation demand. The specific approach will vary for irrigated and non-irrigated conditions, and for each stormwater application. In most



cases, stormwater applications require a permanent irrigation system which shall be designed to maximize water conservation. Irrigation specifications and design plans shall be provided.

Plants such as shrubs and trees grown in naturalized areas that are not saturated to the surface or inundated shall be irrigated with drip irrigation. The irrigation system shall remain in place for a minimum of three years, and should continue until it is demonstrated that the plantings can survive on annual rainfall and/or groundwater. Seeded areas do not need irrigation in years of normal rainfall. If a period of drought occurs after seeding, supplemental watering may be needed for germination in the first year.

The plants on the bottom and edge of the constructed basins should be allowed to become established for one growing season prior to the onset of significant flooding that will inundate the plantings for extended periods. The types of plants recommended for these locations are rushes, sedges, grasses and herbaceous species. Initially, saturated soils are required for the bioretention areas and extended detention basins during the establishment period of the plantings. After the plants have become established, inundation with a surface depth of 1 cm to 2 cm alternating with short dry periods is recommended for the basins during the first year. Periodic shallow flooding of these basins can slow the growth of non-native weedy terrestrial species in the wetland system; however, the water depth should not be greater than the height of the plants. This initial irrigation regime will prevent plant mortality from dry periods or excessive flooding in the first year, and reduce the growth of non-native weedy species.

Emergent species should be planted in saturated soil so the plants will become established. For emergent species, the water level in the first year should be maintained to allow for soil saturation or shallow inundation around the base of the plants. Significant flooding and inundation of stems and leaves of the plants should be avoided the first year. Tall plugs and plantings can tolerate greater depths of inundation if a significant portion of the stems and leaves of the plantings remain above the water surface.

## B.5 Monitoring and Maintenance

### General Requirements

All planted areas shall be monitored and maintained as required to ensure proper establishment by a Contractor with a valid California C-27 contractor's license. Frequency of site visits and required maintenance practices will vary depending upon the stormwater measure and plant selection. Maintenance shall include watering, cultivation, weeding and pruning as necessary to maintain optimum growth conditions and, as appropriate to the specific stormwater measure, to keep the planted areas neat and attractive in appearance. In all instances, controlling weeds and unwanted growth with chemical applications is prohibited.

The contractor shall be familiar with the design and function of the specific stormwater measure(s) to ensure that the plantings are maintained appropriately and do not interfere with the efficient runoff drainage and filtration.

Ongoing management of invasive weed species is required in all applications. Monthly hand weeding will allow the naturalized vegetation to take hold, and will ultimately be less costly than less frequent, and more intensive clearing. Regular application of compost mulch, or other

mulch material that will resist floating with surface runoff (such as pea gravel, rock, cobble, or large float-resistant wood mulches), will also help control weed growth. “Micro-bark” or “gorilla hair” mulches are not recommended.

#### Erosion Control

Particularly with landscapes that are not fully established, contractors will need to monitor and evaluate potential for erosion and sediment accumulation in the runoff, which will influence irrigation scheduling and as well as determine the need for additional erosion control measures. Soil can be protected from erosion by a number of methods including:

- Keep the soil covered with vegetation to the extent possible;
- Slow water runoff by using compost berms, blanket, socks or tubes along slopes;
- Cover bare soil with a minimum of 3 inches of mulch cover;
- Minimize the use of blowers in planting beds and on turf;
- On slopes use coarse shredded mulch that is not prone to washing into storms drains (“micro-bark” and “gorilla hair” mulches are not recommended for this application);
- Store leaf litter as additional mulch in planting beds as appropriate.

#### Irrigation Systems

Where irrigation systems have been installed for temporary or permanent irrigation, the contractor shall maintain the irrigation system for optimum performance, as per manufacturer’s specifications. Contractor shall inspect the entire system on an ongoing basis, including cleaning and adjusting all sprinkler and bubbler heads, drip emitters and valves for proper coverage. Contractor shall monitor the irrigation system while operating to identify and correct problems with water runoff or standing water.

Monitor soil moisture within plant root zones using a soil probe or shovel and adjust irrigation schedules accordingly if a soil moisture sensor is not being utilized to signal the irrigation controller. If a Weather-Based Irrigation Controller (WBIC), otherwise known as a “Smart” Controller is not utilized on the project, irrigation shall be scheduled using a water budget approach, basing irrigation frequency on evapotranspiration data (ET) to avoid over-irrigation of plant material. Adjust irrigation frequency within each hydrozone area a minimum of every four weeks to respond to expected adjustments in ET data.

If a standard turf mix is used in lieu of a no-mow variety, implement grasscycling, where appropriate to the stormwater treatment measure. Grass clippings shall not be carried into the drainage structures. Refer to A Landscaper’s Guide to Grasscycling available from Rescape California (also known as the Bay-Friendly Landscaping Coalition) at [www.rescapeca.org](http://www.rescapeca.org).

#### Bioretention and Extended Detention Basins

In bioretention and extended detention basins, in particular, non-native invasive plant species should be carefully monitored and controlled to reduce competition with the native plantings and to assure the success of the revegetation activities. The establishment of weeds and invasive species in the bottom of the basins can be partially controlled during the establishment period by implementing the watering schedule of initial saturation followed by alternating

periods of shallow inundation and dry soil. Manual methods of weed removal should be conducted on the bottom, edge and side of the basins when these areas are not inundated. Areas with hydroseeding on the banks of the basins should be weeded carefully to avoid removal of the native species.

Weeding should be conducted regularly the first two years to prevent the growth, flowering, and seed set of non-native weeds and invasive species. After the first two years, weeding frequency will be determined on a site-specific basis as determined by the type of weeds and seasonal growth cycle of the weed species. In general, weeding once a month will be necessary to avoid more extensive and costly eradication in the future.

Long-term maintenance tasks on the banks of the basins will include continued control of nonnative weeds and invasive plants, and control of erosion. Erosion could include gullies, rills and sheet erosion. Actions to control erosion should include redirecting or dissipating the water source. Recontouring and subsequent mulching and/or reseeding with erosion control species may be required in bare areas. In the event of extensive die-off of the native plant species, the bare areas should be replanted. Where the event that caused plant mortality was not a natural catastrophic occurrence, the site condition that resulted in the die-off should be investigated and remedial action to correct the problem should be undertaken prior to replanting.

## B.6 Bay-Friendly Landscaping and IPM

This section provides a summary of Bay-Friendly landscaping and integrated pest management (IPM) techniques, based on Alameda County's Bay Friendly Landscaping Guidelines prepared by Rescape California, also known as the Bay-Friendly Landscaping Coalition (available at [www.rescapeca.org](http://www.rescapeca.org)).

### Bay Friendly Landscaping

Bay-Friendly landscaping is a whole systems approach to the design, construction and maintenance of the landscape in order to support the integrity of the San Francisco Bay watershed. Project sponsors are encouraged to use landscape professionals who are familiar with and committed to implementing Bay-Friendly landscaping practices from the initial plant selection through the long-term maintenance of the site. This section summarizes Bay-Friendly Landscaping practices that may be implemented information that project sponsors need about how these practices can benefit water quality of the Bay and its tributaries.

Bay-Friendly landscaping is based on 7 principles of sustainable landscaping and features the following practices:

1. **Landscape Locally.** Landscapes designed to be part of the larger ecosystem of the Bay Area can both protect the health, diversity and sustainability of this valuable resource while making the most of the natural processes of a well-functioning ecosystem. By selecting plants appropriate to the climate, exposure, soils, drainage and topography, plantings can be established more successfully with less consumption of resources and intensive maintenance. Landscape designers are also encouraged to use local, well-adapted plant communities as models and to consider the potential for fire when developing the plant palette for a project.

2. **Less to the Landfill.** Reducing waste –and thus conserving landfill space and fossil fuel for hauling this material to the landfill - starts with not generating it in the first place. Plant trimmings pruning can be reduced by selecting plants that can grow to their natural size in the space allotted them, by avoiding the use of sheared hedges as design elements and not specifying invasive species (see the list in Appendix B). Prune selectively, and avoid excessive plant growth by applying water and fertilizer judiciously..

The second step is to recognize the value of plant debris, and to keep this organic matter on the site, using it as a gardening resource for mulching and composting.

3. **Nurture the Soil.** Returning organic matter to the soil, in the form of plant debris, is the link between protecting our watershed and protecting our watershed. Healthy soil that is rich in organic matter is full of life and can store water and actively cycle nutrients, regulate and partition water flow, neutralize pollutants, and resist pests. The following practices will encourage a complex soil community of microorganisms, worms, and other beneficial creatures. Base the landscape design on a soil analysis and understanding of soil texture, structure and drainage. The following practices are recommended During construction:

- Remove and store the topsoil for re-spreading after grading;
- Limit construction traffic to areas that will not be landscaped;
- Control soil erosion;
- Amend the soils with compost before planting; and
- Specify and maintain an adequate layer of organic mulch, taking into account water flow and designing to avoid the loss of mulch with runoff.

Maintenance practices to benefit soils and the watershed include allowing grass clippings to remain on the lawn; feeding soils with naturally based products including compost and a water extract of mature compost, instead of synthetic, fast release fertilizers and avoiding pesticides.

4. **Conserve Water.** Amending the soil with compost and keeping it covered with composted mulch (or other mulch that resists floating) can increase soil permeability and water-holding capacity, reduce water loss through evaporation and decrease the need for irrigation. Planting appropriate, drought tolerant California natives or Mediterranean plants also reduces water consumption for irrigation, as well as consumption of other resources for mowing, fertilizing, and spraying. Minimize the use of turf grasses that require regular watering and fertilizing to remain green, particularly on slopes or in narrow, irregular hard to water shapes. Arrange plants in “hydrozones” of low, medium or high water demand. Onsite collection systems can allow the use of rainwater, or the reuse of “graywater” – uncontaminated wastewater from sinks, bathtubs, and washing machines. Specify, install and maintain high-efficiency irrigation systems, and train landscaping staff to manage irrigation according to need.
5. **Conserve Energy.** Conventional landscapes are very fossil fuel consumptive. Selecting plantings that do not require regular mowing or pruning, fertilizing and watering can help reduce this demand and restore our landscapes to those that are more productive than consumptive. Tree plantings can be used to moderate building temperatures, and to shade paved areas and air conditioners. Trees can also intercept significant amounts of rainfall each year and thus help control stormwater runoff. Specify as large a tree as possible but be sure that it will be allowed to grow to its natural shape and size in the

allotted space. Outdoor lighting should be designed to use less energy and minimize “light pollution.” Choose and maintain energy-efficient landscaping equipment to conserve fuel. Specifying local products and suppliers reduces the energy needed to transport products and supports local economies.

6. **Protect Water and Air Quality.** Bay-Friendly landscaping can help protect water quality by increasing on-site infiltration and reducing runoff, reducing pollutants in runoff, and increasing the soil’s ability to remove pollutants from runoff. It can help protect air quality by reducing fossil fuel consumption, recycling plant debris onsite, and planting trees to remove carbon dioxide and absorb air pollutants. Many of the practices described previously, such as minimizing high input decorative lawns, keeping soil covered with mulch and planting trees play a critical role in protecting water and air quality. An additional very important component of Bay-Friendly landscaping is reducing the use of pesticides through integrated pest management, which is described in a separate section, below.
7. **Create and Protect Wildlife Habitat.** Although we tend to rely on parks and open space to preserve wildlife habitat, developed landscapes can also provide food, water, shelter and nesting sites for birds, butterflies, beneficial insects, and other creatures. This can be accomplished by providing a diverse landscape that includes annuals, biennials and perennials of many different sizes, shapes, colors and textures; by choosing California natives first; providing appropriate water and shelter for wildlife; eliminating the use of pesticides; and planning sites to conserve or restore natural areas and wildlife corridors.

#### Integrated Pest Management

All creeks in the San Francisco Bay Area exceed water quality toxicity limits, primarily due to the pesticide Diazinon entering urban runoff. Although the residential use of Diazinon is currently being phased out, the use of a group of highly toxic chemicals, called pyrethroids, is increasing. Because all pesticides are toxins, integrated pest management (IPM) places a priority on avoiding their use. IPM is a holistic approach to mitigating insects, plant diseases, weeds, and other pests. Projects that require a landscaping plan as part of a development project application are required encouraged to use IPM, as indicated in each agency’s source control measures list, which is based on the Clean Water Program’s Source Control Model List. Avoiding pesticides and quick release synthetic fertilizers are particularly important when maintaining stormwater treatment measures, to protect water quality.

IPM encourages the use of many strategies to first prevent, and then control, but not eliminate, pests. It places a priority on fostering a healthy environment in which plants have the strength to resist diseases and insect infestations, and out-compete weeds. Using IPM requires an understanding of the life cycles of pests and beneficial organisms, as well as regular monitoring of their populations. When pest problems are identified, IPM considers all viable solutions and uses a combination of strategies to control pests, rather than relying on pesticides alone. The least toxic pesticides are used only as a last resort. IPM features the following practices:

- **Prevent Pest Problems.** Fostering a healthy soil and selecting appropriate plant communities for the site helps reduce the susceptibility to disease and other pests. Landscape designs should include a diversity of species that are well-suited to the site; specify resistant varieties and native species, including plants that attract beneficial insects; place plants a proper distance from buildings; avoid over-planting; and include compost in

the soil specifications. Cultural methods of avoiding pests during construction and maintenance include the following:

- Selecting plant material that is free from disease and insects;
  - Planting at the right depth;
  - Watering thoroughly but not over-watering;
  - Keeping mulch on the soil surface at all times, keeping it away from root crowns;
  - Using slow release fertilizer, if necessary, and not over-fertilizing;
  - Pruning judiciously;
  - Eliminating noxious weeds before they go to seed or spread;
  - Cleaning equipment after use on infected plants;
  - Inspecting and removing invasive plant parts or seeds from clothing, tools and vehicle before leaving an infected site; and
  - Cleaning up fruit and plant material that is infected with insects or diseases.
- **Watch for and Monitor Problems.** Landscaping firms should provide their staff with the time and resources to learn to identify both pest and beneficial organisms, and train residential clients to monitor and record pest problems. Plants should be checked often for vigor and signs of pests. Clarify which problems are the result of pests and not other environmental problems. Evaluate the results of any treatments, and check regularly with the Bio-Integral Resource Center ([www.birc.org](http://www.birc.org)) or UC Davis ([www.ipm.ucdavis.edu](http://www.ipm.ucdavis.edu)) for up-to-date resources and information.
  - **Education is Key.** Many property owners have unrealistic standards of absolute pest control and need to learn how landscapes can tolerate a certain level of pests without resulting in significant, or even noticeable, damage. Landscape professionals should educate their clients and refer them to [www.ourwaterourworld.org](http://www.ourwaterourworld.org) for fact sheets and information on alternative pest control strategies.
  - **Use Physical and Mechanical Controls.** If pests are identified as causing unacceptable levels of damage, physical barriers or mechanical techniques are the first line of control. This can include the carefully timed and conducted pruning of infested plant material or removal of whole plants, spraying aphids with a strong jet of water, using pheromone or sticky traps to keep ants and other insects away or hand-picking large adult insect pests and larvae as they appear
  - **Use Biological Controls.** Living organisms can also be used to keep pest populations under control. The most important biological controls appear naturally and will be abundant in a landscape that is not heavily treated with pesticides. Encourage beneficial insects by planting a wide range of plants that flower throughout the year (a list is provided in the Bay-Friendly Landscaping Guidelines), and introduce natural predators. Buy all biological controls from a reputable source, and do not use pesticides except as a last resort.
  - **Least Toxic Pesticides are a Last Resort.** The least toxic and least persistent pesticide is used only when monitoring indicates that preventative and non-chemical methods are not keeping pests below acceptable levels. Pesticides are not used on a calendar basis. When used, their efficiency is maximized by understanding the pest and beneficial life cycles, by careful timing and targeted application.

## B.7 Nursery Sources for Native Plants

It is recommended that the native plants used in treatment controls be grown by a qualified nursery. Seed collection should be conducted by a qualified botanist and/or nursery staff. Seed should be collected locally from selected sites to maintain the genetic integrity of the native plant species. The seeds shall be propagated by the nursery for planting during the fall dormant season. The appropriate container size for each species shall be used by the nursery.

Berkeley Horticultural Nursery\*  
1310 McGee Ave., Berkeley, CA  
510-526-4704  
<http://www.berkeleyhort.com/>

Clyde Robin Seed Company  
Castro Valley, CA  
510-785-0425  
[www.clyderobin.com](http://www.clyderobin.com)

East Bay Nursery\*  
2332 San Pablo Ave., Berkeley, CA  
510-845-6490  
<http://www.eastbaynursery.com/>

Larner Seeds  
PO Box 407  
Bollinas, California  
415-868-9407, [info@larnerseeds.com](mailto:info@larnerseeds.com)  
[www.larnerseeds.com/](http://www.larnerseeds.com/)

Mines Road Natives  
17505 Mines Road, Livermore, CA  
925-371-0887 (Note: by appointment only)

Mostly Natives Nursery  
27235 Highway 1, Tomales, CA  
707-878-2009  
[www.mostlynatives.com](http://www.mostlynatives.com)

Native Here Nursery  
101 Golf Course Road, Berkeley, CA  
510-549-0211  
[www.ebcnps.org](http://www.ebcnps.org) (click on "Native Here Nursery")

Oaktown Native Plant Nursery  
1019 Bella Vista Ave., Oakland, CA  
510-534-2552  
<http://www.oaktownnativenursery.info/>

Pacific Coast Seed  
533 Hawthorne Place  
Livermore, CA  
925-373-4417  
[www.pcseed.com](http://www.pcseed.com)

Watershed Nursery

Berkeley, CA

510-548-4714

[www.thewatershednursery.com](http://www.thewatershednursery.com)

\* Nurseries with a dedicated native plant section

## References

A. Rescape California (also known as the Bay-Friendly Landscaping Coalition)  
[www.rescapeca.org](http://www.rescapeca.org)

1. Bay-Friendly Landscape Guidelines
2. A Landscaper's Guide to Grasscycling
3. A Landscaper's Guide to Mulch

B. A Guide to Estimating Irrigation of Water Needs of Landscape Plantings, California Dept of Water Resources, <http://cdec.water.ca.gov>

C. Irrigation water audits, Irrigation Association, [www.irrigation.org](http://www.irrigation.org), and the Irrigation Technology Research Center, [www.itrc.org](http://www.itrc.org).

D. California Irrigation Management Information System, [www.cimis.water.ca.gov](http://www.cimis.water.ca.gov), Waste management and recycling, [www.ciwmb.ca.gov](http://www.ciwmb.ca.gov).

E. The Weed Worker's Handbook, A Guide to Techniques for Removing Bay Area Invasive Plants, The Watershed Council (510) 231-5655 and the California Invasive Plant Council (510) 843-3902

F. Pests of Landscape Trees and Shrubs: An Integrated Pest Management Guide, 2nd ed., UC Publication 3359, <http://www.ipm.ucdavis.edu>

G. A Field Guide to Compost Use, The Composting Council, Alexandria, VA.  
<http://www.compostingcouncil.org/index.cfm>

H. City of Santa Rosa. 2005. Appendix A. Landscaping and Vegetation for Storm Water Best Management Practices in New Development and Redevelopment in the Santa Rosa Area.

I. Hogan, E.L., Ed. 1994. Sunset Western Garden Book, Sunset Publishing Corporation, Menlo Park, CA.

J. California Stormwater Quality Association (CASQA). Stormwater BMP Handbook: New Development and Redevelopment. January 2003.

K. Bornstein, Carol, David Fross and Bart O'Brien, California Native Plants for the Garden

L. East Bay Municipal Utility District (EBMUD), Plants and Landscapes for Summer Dry Climates

M. University of California Cooperative Extension, Guide to Estimating Irrigation Water Needs of Landscape Plantings in CA